

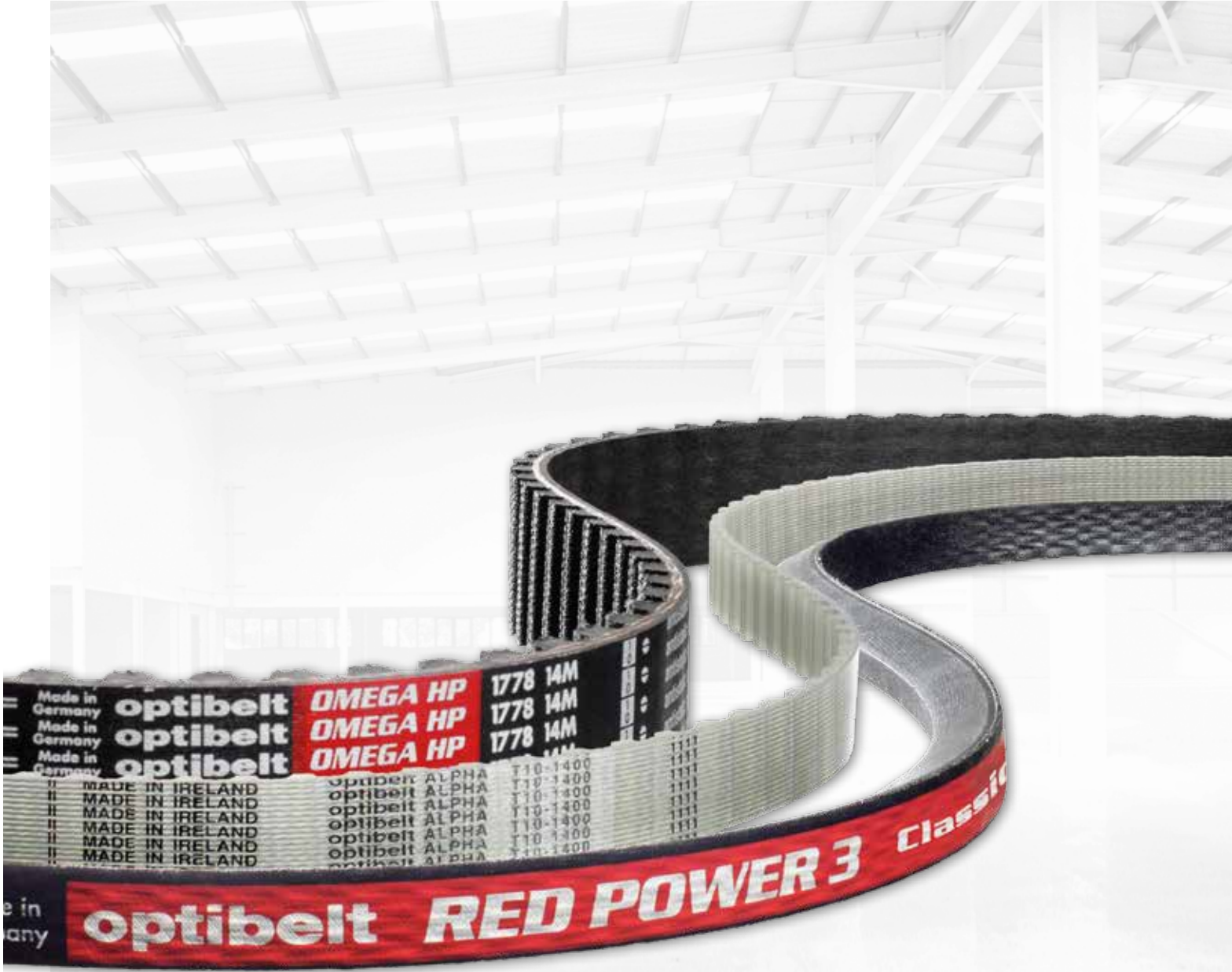

**OPTIBELT**  
**INDUSTRIAL POWER TRANSMISSION CATALOG**





## S=C PLUS INDUSTRY LEADING V-BELTS

- No matched sets needed
- Increased drive efficiency
- Less maintenance costs

- No time spent putting together belt sets
- Reduced adjustment and calibration

### INDUSTRY LEADING ACCURACY

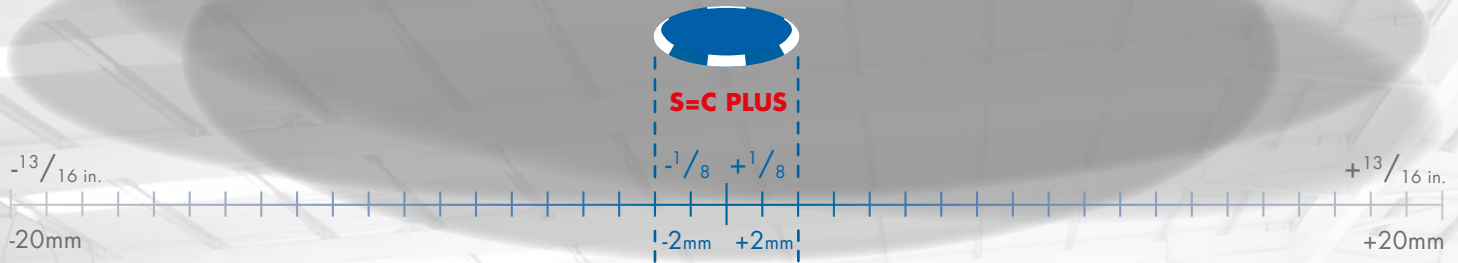

## IS YOUR BELT MISSING THE MARK?

When you order belts, do you know how accurate their length is? Are you aware of how much additional maintenance and inefficiency is costing your business? OPTIBELT does and that is why we have manufacturing processes that far exceed industry accepted standards.

Identical size v-belts will always vary in length depending on a variety of conditions such as heat, humidity, material composition, etc. when manufactured.

For example a B100 belt the industry accepted length variance is  $\pm 13/16$  in. in accordance with industry standards. That is a possible variance of over 1-1/2 in.! This standard is what belt manufacturers use when measuring their tolerances.

OPTIBELT holds itself to a higher standard. Utilizing OPTIBELT's Rotary Vulcanization manufacturing process and additional quality control methods all B100 S=C PLUS belts will vary less than 1/4 in.! This accuracy is unmatched in the industry.



#### VB

Classic v-belts engineered for superior performance and efficiency.



#### SK

Standard & metric v-belts engineered for superior performance and efficiency.



#### HVAC POWER

Specifically engineered solution for unique industry conditions.



#### RED POWER 3

The only maintenance-free v-belts in the industry for revolutionary cost-savings.



## ORV OPTIBELT Rotary Vulcanization

OPTIBELT's vulcanization process tightly controls the manufacturing process where belt lengths typically vary.

In addition to OPTIBELT's ORV process, many other procedures ensure quality in every belt we make:

- High-Quality Materials
- Continuous Vulcanization (cure) Process
- Cord Stabilization Process
- Layered Construction
- Accurate & Repeatable Manufacturing

**NOTE:** S=C PLUS length tolerances are applicable to all polyester cord wrapped v-belts 47" in length and above. All HVAC POWER belts are manufactured to S=C PLUS tolerances regardless of length.



## WHO IS OPTIBELT?

OPTIBELT is part of the Arntz OPTIBELT Group which is a multinational belt manufacturer that has been in business for over 140 years. The Arntz OPTIBELT Group has operations, manufacturing and distribution facilities located around the world. It is headquartered in Höxter Germany which also has engineering, testing, and R&D facilities.

The Arntz OPTIBELT Group is one of the world's largest manufacturers of high quality power transmission drives producing products for Industrial Power Transmission, Automotive, Material Handling, Elastomer Applications and more.

OPTIBELT USA is part of the Arntz OPTIBELT Group and supplies customers in North & South America and Canada. These facilities are located at:

### USA

#### OPTIBELT, USA HEADQUARTERS

565 E. Fullerton Ave., Carol Stream, IL 60188

Phone: 800-292-6081 Fax: 800-542-9510

E-Mail: info@optibelt-usa.com

Warehouse and distribution facilities are located in:

**South Carolina - Texas - Illinois - California**

### MEXICO & SOUTH AMERICA

#### OPTIBELT, MEXICO

Avenida 5 de Febrero 1702-C,  
Bodega 5, Colonia las Americas  
76121 Santiago De Queretaro, Mexico

Phone: +52 442-210-3741

E-Mail: info@optibelt.mx

OPTIBELT, SOUTH AMERICA (BRAZIL)  
Rua das Castanheiras No. 200 Galpao No. 84  
CEP -13187-065 Jd. Sao Pedro, Hortolândia, SP  
Brazil

Phone: +55 (11) 3804-4854

E-Mail: optibelt Dobrasil@optibelt.com

LATIN AMERICA E-Mail: latin-info@optibelt.com

### CANADA

#### OPTIBELT, TORONTO

351 Steelcase Road West, Unit 8 & 9  
L3R 4H9 Markham, Ontario/Canada

Phone: 905-477-8114

Fax: 905-477-0857

E-Mail: info@optibelt.ca

#### OPTIBELT, MONTREAL

4915, Place Olivia, Suite 100  
H4R 2V6 Saint-Laurent, QC

Phone: 514-856-0550

Fax: 514-856-1790

## WHAT SETS US APART?

The Arntz OPTIBELT group invests in Engineering and Manufacturing processes and technology. This makes us the leader in quality, innovative and durable products that set the standard for the power transmission industry. These innovations include:

### S=C PLUS (Set-Constant)

Superior to industry standards for a matched-set. Any two S=C Plus V-belts are always superior to a matched-set regardless of the date

manufactured. NOTE: Standard on all OPTIBELT single V-belts and Wedge belts 47" in length and above. (N.A. aramid cord belts)

### CUT TO SIZE WIDTHS

Customers get greater flexibility when they are ordering banded, timing or ribbed belts. Every OPTIBELT facility cuts belts to size so there is no wait for custom orders from the factory.

### METRIC SIZES

OPTIBELT'S international presence make us the leading supplier of metric belts in the world.

### HVAC POWER

Specific HVAC engineered V-belts can withstand extreme temperatures, extend maintenance intervals, are very flexible, and have S=C Plus length tolerances.

### BLUE POWER: Aramid Cord

BLUE POWER V-belts are the strongest available for heavy industrial applications and their high-grip cover is dual wrapped for increased durability.

### RED POWER: Maintenance-Free

RED POWER 3 is the only maintenance-free belt. The cord is made with a custom polymer that keeps the belt tensioned throughout its life.

RED POWER belts also offer up to a 50% increase in power transfer capacity, a transverse fiber core, and a dual wrapped cover for dramatically longer belt life.

## WHY CUSTOMERS CHOOSE OPTIBELT.

### MORE DURABILITY

Customers that have a difficult drive set-up or application where standard belts are over-stressed, products such as optibelt's RED POWER 3 often solves these issues.

### GREATER EFFICIENCY

Customers seeking to optimize their facilities will discover OPTIBELT's superior wear resistance and high power transfer capacity will reduce yearly costs.

### REDUCED MAINTENANCE

When customers are looking to reduce downtime or overall maintenance costs, OPTIBELT offers the only maintenance-free belt in the industry: RED POWER 3.

### REDUCED COSTS

OPTIBELT's superior manufacturing processes ensure every belt has the quality built-in to increase performance & durability and can reduce maintenance, replacement and energy costs.

### LOCAL AVAILABILITY

7 warehouses strategically located throughout North America.

## ENGINEERING SERVICES

### CAP PROGRAM

OPTIBELT offers customers the ability to use our free drive calculation and optimization software tools. No matter if you are designing a motor/drive system or trouble-shooting issues, OPTIBELT's CAP program can help.

### SUPPORT & DESIGN

OPTIBELT can work with your company to design, produce and manufacture belts that meet a wide variety of needs. Our engineering department assists many of the top OEM's to develop solutions that help produce products that are more compact and deliver the power and performance customers demand.

Contact an OPTIBELT representative for more information.



# TABLE OF CONTENTS

PAGE	PRODUCT
• PAGE	SECTION/PITCH: SIZES

## V-BELTS, SINGLE

- 11 BLUE POWER** ARAMID CORD
  - 11 SECTIONS: 5V, 8V
- 12 HVAC POWER** FRACTIONAL HORSEPOWER
  - 12 SECTIONS: A/4L, B/5L
- 13 RED POWER 3** MAINTENANCE-FREE
  - 14 SECTIONS: A, B
  - 15 SECTIONS: 3V, 5V, 8V
  - 16 SECTIONS: SPZ, SPA
  - 17 SECTIONS: SPB, SPC
- 18 VB** CLASSICAL SECTIONS
  - 18 SECTIONS: A, B
  - 19 SECTIONS: B, C
  - 20 SECTIONS: C, D, E
  - 21 SECTIONS: 5, 6, 8
  - 22 SECTIONS: 10
- 23 SK** STANDARD & METRIC SECTIONS
  - 23 SECTIONS: 3V, 5V, 8V
  - 24 SECTIONS: SPZ, SPA
  - 25 SECTIONS: SPA, SPB
  - 26 SECTIONS: SPC
- 27 LD** FRACTIONAL HORSEPOWER
  - 27 SECTIONS: 3L, A/4L
  - 28 SECTIONS: A/4L, B/5

## V-BELTS, COGGED

- 29 SUPER X-POWER** STANDARD & METRIC
  - 29 SECTIONS: 3VX, 5VX
  - 30 SECTIONS: XPZ, XPA
  - 31 SECTIONS: XPA, XPB, XPC
- 32 SUPER TX** CLASSICAL
  - 32 SECTIONS: AX, BX
  - 33 SECTIONS: BX, CX

## V-BELTS, BANDED

- 34 BLUE POWER** ARAMID CORD
  - 34 SECTIONS: 5V, 8V
- 35 RED POWER 3** HIGH PERFORMANCE
  - 35 SECTIONS: 3V, 5V, 8V
  - 36 SECTIONS: SPB, SPC

sizes cont...

## V-BELTS, BANDED

- 37 KB**
  - 37 SECTIONS: B, C
  - 38 SECTIONS: D
  - 39 SECTIONS: 3V, 5V, 8V
  - 40 SECTIONS: SPZ, SPA, SPB
  - 41 SECTIONS: SPC
- 42 KBX** COGGED
  - 42 SECTIONS: BX, 3VX, 5VX

## SPECIALTY

- 43 VARIO POWER** VARIABLE SPEED
  - 43 IMPERIAL SIZES (US STD.)
  - 44 METRIC SIZES
- 45 DK** V-BELTS, DOUBLE SIDED
- 46 KK & RR** URETHANE ROUND & V-BELTS
- 47 WR** WIDE ANGLE V-BELTS
- 48 OPTIMAT OE, DK & FK** OPEN-ENDED V-BELTS
- 49 PKR** CONVEYOR V-BELTS

## PG 50-51 RB RIBBED BELTS

- 50 SECTIONS: J/PJ
- 57-58 SECTIONS: L/PL, M/PM

## TIMING BELTS, CHLOROPRENE

- 52 OMEGA HL** HIGH TORQUE
  - 52-54 PITCH: 8M
  - 54 PITCH: 8M, 14M
- 55 OMEGA HP** HIGH PERFORMANCE
  - 55-56 PITCH: 3M
  - 57-58 PITCH: 5M
  - 59-60 PITCH: 8M
  - 61 PITCH: 14M
- 62 OMEGA**
  - 62 PITCH: 2M
  - 63-64 PITCH: 3M
  - 65-66 PITCH: 5M
  - 67-68 PITCH: 8M
  - 69 PITCH: 14M
- 69 OMEGA D**

sizes cont...



# TABLE OF CONTENTS

PAGE	PRODUCT
• PAGE	SECTION/PITCH: SIZES

**TIMING BELTS, CHLOROPRENE**

**70 FAN POWER CERTIFIED ANTI-STATIC**

- 70 PITCH: 8M, 14M

**70 STD & HTD**

**TIMING BELTS, NEOPRENE**

**71 ZR**

- 71-72 PITCH: MXL
- 73-76 PITCH: XL
- 77-78 PITCH: L
- 79-81 PITCH: H
- 82 PITCH: XH, XXH

**73 ZR, DOUBLE SIDED**

- 83 PITCH: D-XL , D-L,
- 84 PITCH: D-DH

**TIMING BELTS, POLYURETHANE**

**85 ALPHA TORQUE & ALPHA POWER**

- 85 PITCH: T2.5
- 86-89 PITCH: T5
- 90-93 PITCH: T10
- 94-95 PITCH: AT5
- 95-96 PITCH: AT10
- 97-98 PITCH: XL (TORQUE ONLY)
- 99 PITCH: L (TORQUE ONLY)
- 100-101 PITCH: DT5
- 101-102 PITCH: DT10

**103 ALPHAFLEX**

- 103 PITCH: T5, T10, T20
- 104 PITCH: AT5, AT10, AT20
- 105 PITCH: 5M, 8M
- 106 PITCH: 14M

**TIMING BELTS, LINEAR**

**107 ALPHA, POLYURETHANE**

- 107 PITCH: XL-XH, 5M-14M
- 108 PITCH: T5-T20, AT5-AT20 F2, F2.5, F3

**109 ZR, NEOPRENE**

- 109 PITCH: XL-H, 3M-14M

**110 CP CLAMPING PLATES**

- 110-111 PITCH: XL-H, 3M-14M

**BUSHINGS & SHEAVES**

**112 KS SHEAVES**

- 112 SECTIONS: 3V
- 113-114 SECTIONS: 5V
- 115 SECTIONS: 8V

**116 KS H SHEAVES FOR QD BUSHINGS**

- 116-117 SECTIONS: B
- 118-119 SECTIONS: C
- 120 SECTIONS: A, 2A
- 121 SECTIONS: B
- 122-123 SECTIONS: 2B

**124 KS SHEAVES, METRIC**

- 124-125 SECTIONS: SPZ/10
- 126-127 SECTIONS: SPA/13
- 128-130 SECTIONS: SPB/17
- 131-132 SECTIONS: SPC/22

**133 KS SHEAVES BORED TO SIZE**

- 133-137 SECTIONS: 3L & 4L/A
- 138-142 SECTIONS: 4L/A & 5L/B

**143 TB TAPER LOCK BUSHINGS**

**144 QD BUSHINGS**

**MAINTENANCE**

**146-148 TECH TOOLS**

**149 TENSION GUIDE**

**150 INSTALL & STORAGE TIPS**

**SERVICE SOLUTIONS**

**151-152 V-BELTS**

**153-154 RIBBED BELTS**

**155-157 TIMING BELTS**

**158 DRIVES & SHEAVES**

**REFERENCE**

**159-161 BELT CONVERSION TABLES**

**162-163 SECTION SIZES**

**164-167 PRODUCT SELECTION GUIDE**  
SELECT THE RIGHT BELT FOR YOUR NEEDS

**163 WEIGHTS & MEASUREMENTS**



## PRODUCT RANGE

### SINGLE & BANDED V-BELTS

#### optibelt BLUE POWER PG 11 & 35

SINGLE & BANDED V-BELTS, ARAMID CORD

The ultimate in power transmission capabilities in heavy industrial applications. The aramid cord gives it more than twice the power transfer capacity of conventional belts. Aramid cord is not the only thing that makes BLUE POWER stand out from other belts. It also features a dual wrapped cover, aligned fiber core and much more. Available in single or banded sizes.

- **More Power:** Capable of transferring up to 2X more power than conventional belts which makes it ideal for heavy industry applications.
- **Increased Life:** Rubber impregnated dual fabric wrap is bonded with the belt's core for superior durability.
- **Greater Efficiency:** The belt's fabric wrap increases the belts ability to grip in the sheave.
- **Temperature Range:** Increased operational range from -22 to 212°F.
- **Anti-static:** Meets ISO 1813 requirements for being anti-static.
- **Back-bend:** Flex range accommodates difficult idler stress.

PROFILES: 5V, 8V

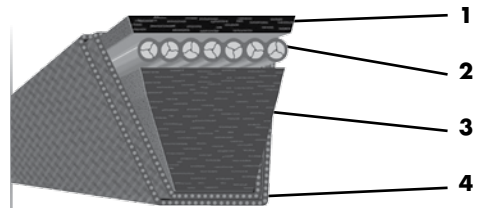

- 1 transverse fiber polychloroprene top layer
- 2 aramid tension cord
- 3 transverse fiber polychloroprene core
- 4 dual wrapped, abrasion-resistant cover fabric

#### optibelt HVAC POWER PG 12

V-BELTS, HIGH PERFORMANCE FRACTIONAL HORSEPOWER

Specifically engineered to meet the demands of HVAC motors and drives.

- **Highly Flexible:** Engineered flexibility to fit a wide variety of small variable pitch adjustable motor pulleys.
- **Increased Life:** Rubber impregnated dual fabric wrap is bonded with the belt's core for superior durability.
- **More Efficient:** Premium low stretch cord ensures better contact throughout the belts life.
- **Temperature Range:** Increased operational range from -22 to 212°F.
- **Low Noise:** Belt fabric wrap reduces noise often attributed to the use of raw edge belts.
- **Matched-Sets:** Features OPTIBELT's S=C Plus manufacturing tolerances.

PROFILES: A/4L, B/5L

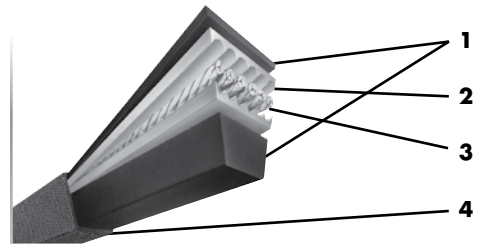

- 1 polychloroprene top layer & core
- 2 flexible cord binding/bedding compound
- 3 low-stretch polyester cord
- 4 dual wrapped, abrasion-resistant cover fabric

#### optibelt RED POWER 3 PG 13-17 & 35-36

V-BELTS, HIGH PERFORMANCE, NO-MAINTENANCE

A revolutionary belt that requires no tension maintenance throughout its lifetime, is more resistant to wear, and transfers up to 50% more power than conventional belts. This means you will get more value and performance than ever thought was possible.

- **No-Maintenance:** No re-tensioning required throughout the life of the belt.
- **More Power:** Capable of transferring up to 50% more power than conventional belts.
- **Matched-Sets:** Features OPTIBELT's S=C Plus manufacturing tolerances.
- **Shock Resistant:** Dampening qualities make it perfect for shock load applications.
- **Increased Life:** Rubber impregnated dual fabric wrap is bonded with the belt's core for superior durability.
- **Greater Efficiency:** Up to 97% efficient at transferring power.
- **Temperature Range:** Increased operational range from -22 to 212°F.
- **Anti-static:** Meets ISO 1813 requirements for being anti-static.
- **Back-bend:** Flex range accommodates difficult idler stress.

PROFILES: A, B 3V, 5V, 8V SPZ, SPA, SPB, SPC

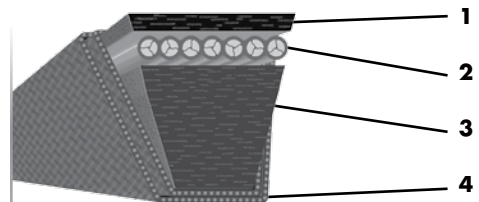

- 1 transverse fiber polychloroprene top layer
- 2 polyester tension cord, maintenance-free
- 3 transverse fiber polychloroprene core
- 4 dual wrapped, abrasion-resistant cover fabric



**optibelt VB PG 18-22**

V-BELTS, CLASSICAL PROFILES

The classic among drive belts due to its universal use in industrial applications. OPTIBELT's superior construction and manufacturing processes make the VB a high quality choice for companies looking for superior performance and lower maintenance costs over standard belts.

- **Reliable:** Superior resistance to stretching and premature wear.
- **Increased Life:** Rubber impregnated and dual fabric wrapped to bond with the belt's core material and increase durability.
- **Greater Efficiency:** The belt's fabric wrap increases the belts ability to grip in the sheave.
- **Matched-Sets:** Features OPTIBELT's S=C Plus manufacturing tolerances.
- **Temperature Range:** Increased operational range from -40 to 158°F.

PROFILES: A, B, C, D, E 5, 6, 8, 10

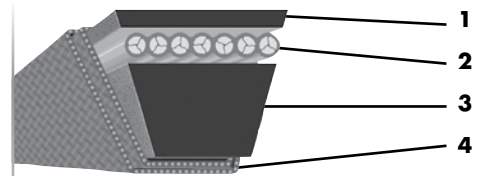

- 1 polychloroprene top layer
- 2 polyester tension cord
- 3 core rubber compound
- 4 dual rubber impregnated cover fabric

**optibelt SK PG 23-26**

V-BELTS, METRIC & STANDARD PROFILES

The standard for industrial applications with OPTIBELT's superior construction and manufacturing processes. The SK is the preferred choice over standard low-cost only options for superior performance and lower maintenance costs.

- **Reliable:** Superior resistance to stretching and premature wear.
- **Increased Life:** Rubber impregnated dual fabric wrapped bonded with the belt's core for superior durability.
- **Greater Efficiency:** The belt's fabric wrap increases the belts ability to grip in the sheave.
- **Matched-Sets:** Features OPTIBELT's S=C Plus manufacturing tolerances.
- **Temperature Range:** Increased operational range from -40 to 158°F.

PROFILES: 3V, 5V, 8V SPZ, SPA, SPB, SPC

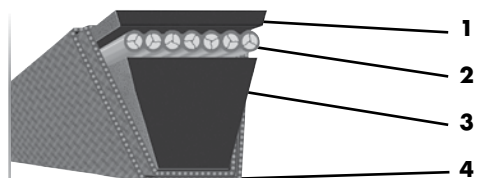

- 1 polychloroprene top layer
- 2 polyester tension cord
- 3 core rubber compound
- 4 dual rubber impregnated cover fabric

**optibelt DK PG 45**

V-BELTS, DOUBLE SIDED

Dual sided V-Belts for multiple pulley applications. Its engineered construction and quality ensures superior performance and durability.

- **Reliable:** Superior resistance to stretching and premature wear.
- **Increased Life:** Rubber impregnated dual fabric wrapped bonded with the belt's core for superior durability.
- **Greater Efficiency:** The belt's fabric wrap increases the belts ability to grip in the sheave.
- **Temperature Range:** Increased operational range from -33 to 185°F.

PROFILES: AA, BB, CC

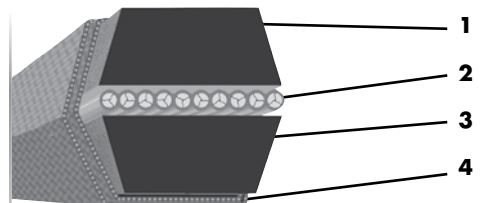

- 1 top core rubber compound
- 2 polyester tension cord
- 3 bottom core rubber compound
- 4 dual rubber impregnated cover fabric

**optibelt LD PG 27-28**

V-BELTS, FRACTIONAL HORSEPOWER

Application specific belts for fractional horsepower (less than 1hp) drives with small sheave diameters. Typical applications include:

- **Washers & dryers**
- **Workshop power tools**
- **HVAC fans & blowers**

PROFILES: 3L, 4L/A, 5L/B

**ALSO SEE:**  
**HVAC POWER**  
**FOR INCREASED DURABILITY,**  
**PERFORMANCE &**  
**YEARLY COST SAVINGS**



# PRODUCT RANGE

## COGGED V-BELTS & RIBBED

### optibelt SUPER X-POWER PG 29-31

#### COGGED V-BELTS, STANDARD & METRIC PROFILES

The high performance solution for cogged belt applications. It is constructed using OPTIBELT'S superior transverse fiber core compound, low stretch polyester cord, and cord stabilizing cushion compound. Available in single or banded sizes.

- **High Performance:** Improves performance 15% over standard raw edged cogged belts.
- **Greater Efficiency:** Low-stretch cords resist stretching for improved efficiency and less maintenance.
- **Temperature Range:** Increased operational range from -20 to 194°F.
- **Matched-Sets (M=S):** Closer than industry matched-set length tolerances.

PROFILES: 3VX, 5VX XPZ, XPA, XPB, XPC

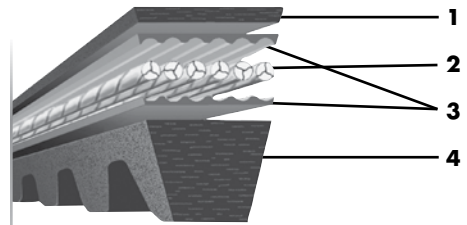

- 1 transverse fiber polychloroprene top layer
- 2 low-stretch polyester tension cord
- 3 cushion & binding compound
- 4 transverse fiber polychloroprene core

### optibelt SUPER TX PG 32-33

#### COGGED V-BELTS, CLASSICAL PROFILES

Advanced construction features such as engineered core rubber and cushioned cord stabilization compound makes it a superior choice. Available in single or banded sizes.

- **Temperature Range:** Increased operational range from -20 to 194°F.
- **Matched-Sets (M=S):** Closer than industry matched-set length tolerances.

PROFILES: AX, BX, CX

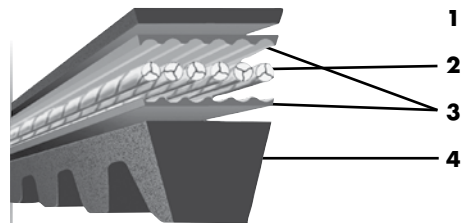

- 1 polychloroprene top layer
- 2 polyester tension cord
- 3 flexible cord binding/bedding compound
- 4 polychloroprene core

### optibelt VARIO POWER PG 43-44

#### VARIABLE SPEED BELTS

These performance belts are engineered to withstand the demands of high capacity drives and extend maintenance intervals.

ADDITIONAL INFORMATION PG. 43



### optibelt RB PG 50-51

#### RIBBED BELTS

RB belts are made from OPTIBELT's superior wear-resistant rubber compound blend. The high strength tension cord is engineered for long-lasting performance and quiet operation.

- **Shock Resistant :** Capable of resisting short-term overloads to protect machinery.
- **Oil Resistant :** Superior rubber compound resists oil absorption.
- **Temperature Range:** Increased operational range from -20 to 194°F.
- **Low Noise :** Runs quieter and resist vibration.
- **Versatile :** Can run with back-bend idler and in serpentine drives.
- **High Performance:** Provides a greater friction surface to transfer more power than conventional ribbed belts.

PROFILES: H/PH, J/PJ, K/PK, L/PL, M/PM







**optibelt OE OPTIMAT PG 48**

OPEN-ENDED V-BELTING, PUNCHED  
This oil and heat resistant open-ended V-Belting can be fitted quickly. Easy to use belt connectors ensure ease of installation.

- **Quick and Easy:** Simple to use connectors
- **Strength:** Fabric filled core provides additional belt and connector strength.
- **US Standard Profiles Available:** A, B, C, D, E
- **Metric Standard Profiles Available:** 6, 8, 10, 20, 25, SPZ, SPA
- **Light-Duty Profiles Available:** 2L, 3L, 4L

PROFILES: A, B, C, D, E 6, 8, 10, 20, 25 SPZ, SPA 2L, 3L, 4L

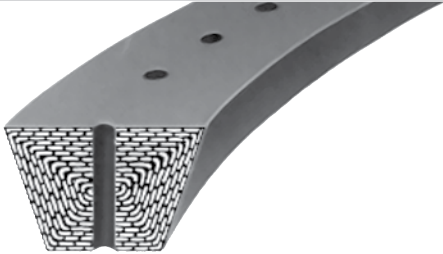

**optibelt PKR PG 49**

SPECIAL TOP SURFACED BELTS  
Application specific belts typically used for the transportation of food, or materials. Available in a wide range of top surfaces. Contact an OPTIBELT representative for more information.

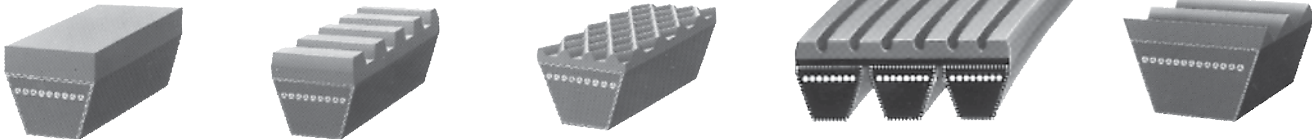

**optibelt KK V-BELT RR ROUND PG 46**

PLASTIC BELTS  
Application specific belts typically used in small applications such as electronic equipment, appliances, and harsh environments such as oil and static exposure. KK belts can also be manufactured with specialized backings. Contact an OPTIBELT representative for more information.



**CUSTOM OPTIONS**

PKR OPTIMAT, KK & RR have a wide variety of options available for specialized applications. Contact an OPTIBELT distributor or representative for further information.



## PRODUCT RANGE

### OMEGA TIMING BELTS

#### optibelt OMEGA HL PG 52-54

Ultra-high performance belt engineered to handle extreme loads at a wide range of speeds.

- **Ultimate Performance:** Large diameter glass fiber cords provide superior strength and pulling force.
- **Low-Noise:** OMEGA tooth design and fabric cover for quieter operation.
- **Durability:** Polyamide fabric cover provides for increased wear resistance.
- **Strength:** Aramid fibers are blended into the rubber compound for a tooth structure with incredible shear strength.
- **Versatility:** Fits HTD® and RPP® pulleys.
- **True-Running:** Counter rotated cords ensure the belt does not have a pull bias.
- **Temperature Range:** Increased operation range -22 to 212°F.
- **Anti-static:** Meets ISO 9563 requirements for being anti-static.

SECTIONS: 8M, 14M

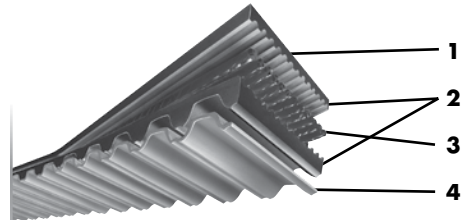

- 1 oil resistant top fabric layer
- 2 aramid reinforced polychloroprene core material
- 3 large diameter glass fiber tension cords
- 4 reinforced polyamide fabric cover

#### optibelt OMEGA HP PG 55-61

High performance belts developed for high speed drives. With its superior construction OMEGA HP belts have the durability and performance characteristics far superior than standard timing belts.

- **High Performance:** Glass fiber cords provide superior strength and pulling force.
- **Low-Noise:** OMEGA tooth design and fabric cover for quieter operation.
- **Durability:** Polyamide fabric cover provides for increased wear resistance.
- **Strength:** Aramid fibers are blended into the rubber compound for a tooth structure with incredible shear strength.
- **Versatility:** Fits HTD® and RPP® pulleys.
- **True-Running:** Counter rotated cords ensure the belt does not have a pull bias.
- **Temperature Range:** Increased operation range -22 to 212°F.
- **Anti-static:** Meets ISO 9563 requirements for being anti-static.

SECTIONS: 3M, 5M, 8M, 14M

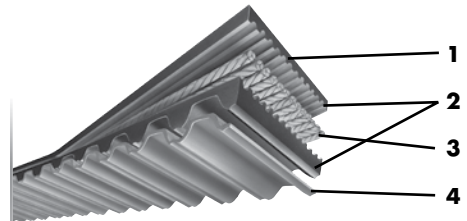

- 1 oil resistant top fabric layer
- 2 aramid reinforced polychloroprene core material
- 3 glass fiber tension cords
- 4 reinforced polyamide fabric cover

#### optibelt OMEGA PG 62-69

OPTIBELT's original timing belt engineered and manufactured to exceed the performance and durability of industry standard belts.

- **Performance:** Glass fiber cords provide superior strength and pulling force.
- **Low-Noise:** OMEGA tooth design and fabric cover for quieter operation.
- **Durability:** Polyamide fabric cover provides for increased wear resistance.
- **Versatility:** Fits HTD® and RPP® pulleys.
- **True-Running:** Counter rotated cords ensure the belt does not have a pull bias.
- **Temperature Range:** Increased operation range -22 to 212°F.
- **Anti-static:** Meets ISO 9563 requirements for being anti-static.

SECTIONS: 2M, 3M, 5M, 8M, 14M

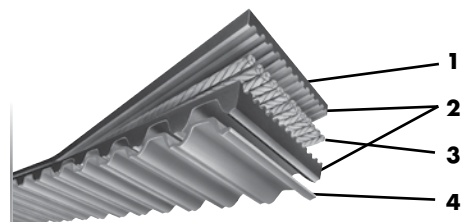

- 1 oil resistant top fabric layer
- 2 polychloroprene core material
- 3 glass fiber tension cords
- 4 polyamide fabric cover



**optibelt OMEGA FANPOWER PG 70**

Designed specifically for oil refinery applications. OMEGA FANPOWER has the same performance as OMEGA HP belts but are certified to be anti-static compliant.

- **High Performance:** Glass Fiber cords provide superior strength and pulling force.
- **Low-Noise:** OMEGA tooth design and fabric cover for quieter operation.
- **Durability:** Polyamide fabric cover provides for increased wear resistance
- **Strength:** Aramid fibers are blended into the rubber compound for a tooth structure with incredible shear resistant strength
- **Versatility:** Fits HTD® and RPP® pulleys
- **True-Running:** Counter rotated cords ensure the belt does not have a pull bias.
- **Temperature Range:** Increased operation range -22 to 212°F
- **Anti-static:** Certified to ISO 9563 requirements for being anti-static.

SECTIONS: 8M, 14M

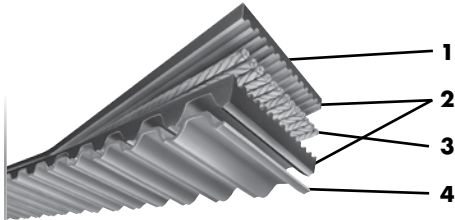

- 1 oil resistant top fabric layer
- 2 aramid reinforced polychloroprene core material
- 3 glass fiber tension cords
- 4 polyamide fabric cover

**optibelt ZR PG 71-84**

Performance ZR timing belts are made from an engineered synthetic rubber neoprene core, glass fiber cords and have an abrasion-resistant protective cover. This engineered combination makes these timing belts extremely durable and efficient at transferring power.

SECTIONS: MXL, XL, L, H, XH, XXH DXL, DL, DH

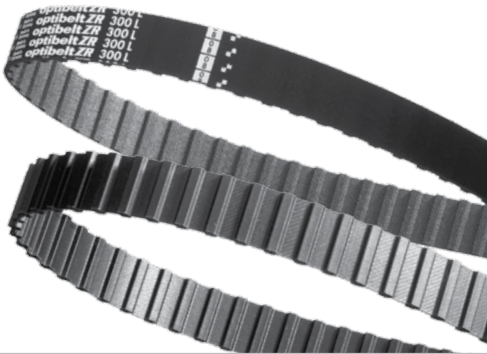

**NEED V-BELT SHEAVES OR BUSHINGS?**

- 112 KS SHEAVES**
- 112 SECTIONS: 3V
  - 113-114 SECTIONS: 5V
  - 115 SECTIONS: 8V

- 116 KS H SHEAVES FOR QD BUSHINGS**
- 116-117 SECTIONS: B
  - 118-119 SECTIONS: C
  - 120 SECTIONS: A, 2A
  - 121 SECTIONS: B
  - 122-123 SECTIONS: 2B
- 124 KS SHEAVES, METRIC**
- 124-125 SECTIONS: SPZ/10
  - 126-127 SECTIONS: SPA/13
  - 128-130 SECTIONS: SPB/17
  - 131-132 SECTIONS: SPC/22
- 133 KS SHEAVES BORED TO SIZE**
- 133-137 SECTIONS: 3L & 4L/A
  - 138-142 SECTIONS: 4L/A & 5L/B
- 143 TB TAPER LOCK BUSHINGS**
- 144 QD BUSHINGS**



# PRODUCT RANGE

## ALPHA POLYURETHANE TIMING BELTS

### optibelt ALPHA POWER PG 85-102

High-performance molded polyurethane belts with steel cords.  
Aramid cords available.

- **High Performance:** Specialized polyurethane material engineered to provide a 30% increase in performance from ALPHA TORQUE belts.
- **Versatility:** Capable of handling a wide variety of applications.
- **Temperature Range:** Increased operation range -22 to 176°F.

SECTIONS: T2.5, T5, T10 AT5, AT10 DT5, DT10



### optibelt ALPHA TORQUE PG 85-102

Molded polyurethane belts with steel cords.  
Aramid cords available.

- **Performance:** Polyurethane material engineered to provide superior performance from standard polyurethane belts.
- **Versatility:** Capable of handling a wide variety of applications.
- **Temperature Range:** Increased operation range -22 to 176°F.

SECTIONS: XL, L T2.5, T5, T10 AT5, AT10 DT5, DT10

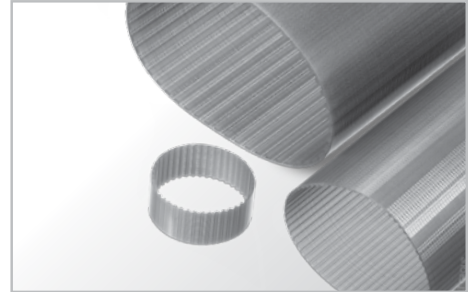

### ALPHA SRP CONVEYOR DRIVES

Custom conveyor drives for specialized manufacturing is a need for more and more businesses. OPTIBELT can manufacture a full range of custom products to customers designed specifications.

Minimum order quantities apply. For more details contact an OPTIBELT representative.

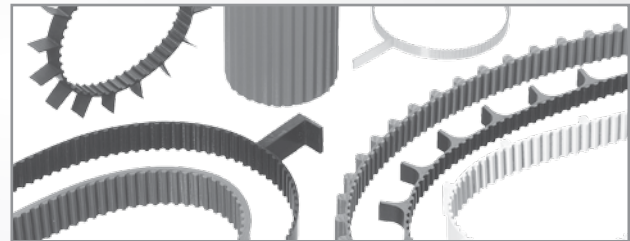

### optibelt ALPHA FLEX PG 103-106

Extruded endless polyurethane belts with steel cords.  
Aramid cords available.

SECTIONS: XL, L, H, XH 8M, 14M T5, T10, T20 AT5, AT10, AT20 D8M, D14M



### optibelt ALPHA LINEAR PG107-108

Extruded linear belts with steel cords.  
Aramid cords available.

SECTIONS: XL, L, H, XH 5M, 8M, 14M T5, T10, T20 AT5, AT10, AT20

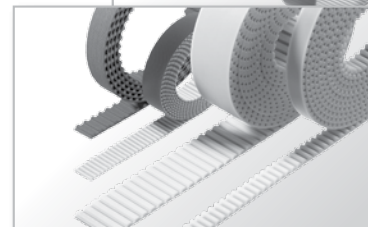

### ALPHA FLEX / LINEAR CUSTOM OPTIONS

OPTIBELT's manufacturing expertise allows custom options such as:

#### CORDS

- High Flexibility Steel
- Stainless Steel
- Aramid

#### BACKING & FINISHES

- Fabrics
- Cleats
- Coatings
- Milled Teeth & Grooves

Contact an OPTIBELT distributor or representative for further information.

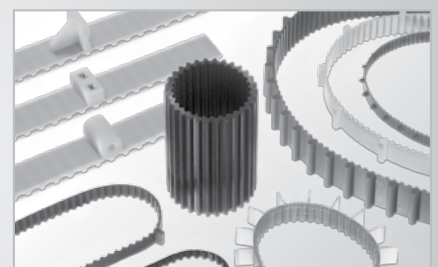



BLUE POWER is the ultimate in power transmission for heavy-duty industrial applications. The aramid cord gives it more than twice the power transfer capacity of conventional belts. It also features a dual wrapped cover, transverse fiber core and more. Available in single or banded sizes.

- **More Power:** Capable of transferring up to 2X more power than conventional belts which makes it ideal for heavy industry applications.
- **Increased Life:** Rubber impregnated dual fabric wrap is bonded with the belt's core for superior durability.
- **Greater Efficiency:** The belt's fabric wrap increases its ability to grip in the sheave.
- **Temperature Range:** Increased operational range from -22 to 212°F.
- **Anti-static:** Meets ISO 1813 requirements for being anti-static.
- **Back-bend:** Flex range accommodates difficult stresses.



SAMPLE PART # : 5VBP900

**STANDARD V-BELTS**

**5V** SECTION : 5/8"W x 17/32"H

PART NO.	OUTSIDE LENGTH (IN)	WEIGHT (LBS)
5VBP500	50	.57
5VBP530	53	.60
5VBP560	56	.64
5VBP600	60	.68
5VBP630	63	.71
5VBP670	67	.76
5VBP710	71	.80
5VBP750	75	.85
5VBP800	80	.90

PART NO.	OUTSIDE LENGTH (IN)	WEIGHT (LBS)
5VBP850	85	.96
5VBP900	90	1.01
5VBP950	95	1.07
5VBP1000	100	1.12
5VBP1180	118	1.32
5VBP1250	125	1.40
5VBP1320	132	1.47
5VBP1400	140	1.56
5VBP1500	150	1.67

PART NO.	OUTSIDE LENGTH (IN)	WEIGHT (LBS)
5VBP1600	160	1.78
5VBP1700	170	1.89
5VBP1800	180	2.00
5VBP1900	190	2.11
5VBP2000	200	2.22
5VBP2120	212	2.35
5VBP2240	224	2.48
5VBP2360	236	2.62
5VBP2500	250	2.77

PART NO.	OUTSIDE LENGTH (IN)	WEIGHT (LBS)
5VBP2650	265	2.94
5VBP2800	280	3.10
5VBP3000	300	3.32
5VBP3150	315	3.49
5VBP3350	335	3.87
5VBP3550	355	3.92

SAMPLE PART # : 8VBP2800

**STANDARD V-BELTS**

**8V** SECTION : 1"W x 7/8"H

PART NO.	OUTSIDE LENGTH (IN)	WEIGHT (LBS)
8VBP1000	100	3.20
8VBP1060	106	3.39
8VBP1120	112	3.58
8VBP1180	118	3.78
8VBP1250	125	4.00
8VBP1320	132	4.22
8VBP1400	140	4.48
8VBP1500	150	4.80

PART NO.	OUTSIDE LENGTH (IN)	WEIGHT (LBS)
8VBP1600	160	5.12
8VBP1700	170	5.44
8VBP1800	180	5.76
8VBP1900	190	6.08
8VBP2000	200	6.40
8VBP2120	212	6.78
8VBP2240	224	7.17
8VBP2360	236	7.55

PART NO.	OUTSIDE LENGTH (IN)	WEIGHT (LBS)
8VBP2500	250	8.00
8VBP2650	265	8.48
8VBP2800	280	8.96
8VBP3000	300	9.60
8VBP3150	315	10.08
8VBP3350	335	10.72
8VBP3550	355	11.36
8VBP3750	375	12.00

PART NO.	OUTSIDE LENGTH (IN)	WEIGHT (LBS)
8VBP4000	400	12.80
8VBP4250	425	13.60
8VBP4500	450	14.40
8VBP4750	475	15.20
8VBP5000	500	16.00
8VBP5600	560	17.92
8VBP6000	600	19.20

**BLUE POWER single belts are non-stocked items.**

Contact customer service for more details. Additional sizes available.

**NOTE:** Aramid cord belts are not available with S=C Plus length tolerances.

**Custom Sizes & Ordering**

Section / Max. Mfg Lengths / Min. qty.

- 5V / 709 in. / 25
- 8V / 709 in. / 14

Contact customer service for details.

Contact an OPTIBELT representative regarding additional sizes, stock availability and pricing.

All weights are estimated.

Additional sizes and stocking available.



HVAC POWER is specifically engineered to meet the demands of small motors and drives.

**ADDITIONAL FRACTIONAL HORSEPOWER BELTS ON PAGES 27-28**

- **Highly Flexible:** Engineered flexibility to fit a wide variety of small variable pitch adjustable motor sheaves.
- **Increased Life:** Rubber impregnated dual fabric wrap is bonded with the belt's core for superior durability.
- **More Efficient:** Premium low stretch cord ensures better contact throughout the belts life.
- **Temperature Range:** Increased operational range from -22 to 212°F
- **Low Noise:** Belt fabric wrap reduces noise
- **Matched-Sets:** Features OPTIBELT's S=C Plus manufacturing tolerances.



**A** SECTION : 1/2"W x 11/32"H

**V-BELTS**

SAMPLE PART # : A33HVAC

**4L** SECTION : 1/2"W x 11/32"H

ALTERNATE REFERENCE SIZE

PART NO.	ALT. REF. SIZE	OUTSIDE LENGTH (IN)	WEIGHT (LBS)
A18HVAC	4L 200	20	.11
A19HVAC	4L 210	21	.11
A20HVAC	4L 220	22	.12
A21HVAC	4L 230	23	.13
A22HVAC	4L 240	24	.13
A23HVAC	4L 250	25	.14
A24HVAC	4L 260	26	.15
A25HVAC	4L 270	27	.15
A26HVAC	4L 280	28	.16
A27HVAC	4L 290	29	.16

PART NO.	ALT. REF. SIZE	OUTSIDE LENGTH (IN)	WEIGHT (LBS)
A28HVAC	4L 300	30	.17
A29HVAC	4L 310	31	.18
A30HVAC	4L 320	32	.18
A31HVAC	4L 330	33	.19
A32HVAC	4L 340	34	.20
A33HVAC	4L 350	35	.20
A34HVAC	4L 360	36	.21
A35HVAC	4L 370	37	.22
A36HVAC	4L 380	38	.22

PART NO.	ALT. REF. SIZE	OUTSIDE LENGTH (IN)	WEIGHT (LBS)
A37HVAC	4L 390	39	.23
A38HVAC	4L 400	40	.23
A39HVAC	4L 410	41	.24
A40HVAC	4L 420	42	.24
A41HVAC	4L 430	43	.25
A42HVAC	4L 440	44	.26
A43HVAC	4L 450	45	.26
A44HVAC	4L 460	46	.27
A45HVAC	4L 470	47	.28

**B** SECTION : 21/32"W x 7/16"H

**V-BELTS**

SAMPLE PART # : B39HVAC

**5L** SECTION : 21/32"W x 7/16"H

ALTERNATE REFERENCE SIZE

PART NO.	ALT. REF. SIZE	OUTSIDE LENGTH (IN)	WEIGHT (LBS)
B23HVAC	5L 260	26	.25
B24HVAC	5L 270	27	.27
B25HVAC	5L 280	28	.28
B26HVAC	5L 290	29	.29
B27HVAC	5L 300	30	.29
B28HVAC	5L 310	31	.31
B29HVAC	5L 320	32	.32

PART NO.	ALT. REF. SIZE	OUTSIDE LENGTH (IN)	WEIGHT (LBS)
B30HVAC	5L 330	33	.33
B31HVAC	5L 340	34	.34
B32HVAC	5L 350	35	.36
B33HVAC	5L 360	36	.37
B34HVAC	5L 370	37	.38
B35HVAC	5L 380	38	.39
B36HVAC	5L 390	39	.40

PART NO.	ALT. REF. SIZE	OUTSIDE LENGTH (IN)	WEIGHT (LBS)
B37HVAC	5L 400	40	.41
B38HVAC	5L 410	41	.42
B39HVAC	5L 420	42	.42
B40HVAC	5L 430	43	.43
B41HVAC	5L 440	44	.44
B42HVAC	5L 450	45	.45
B44HVAC	5L 470	47	.47

**HVAC POWER BELTS CAN SAVE YOU HUNDREDS OF DOLLARS A YEAR IN REPLACEMENT COSTS AND DECREASE YOUR ENERGY BILLS. ASK AN OPTIBELT REPRESENTATIVE HOW!**

Contact an OPTIBELT representative regarding additional sizes, stock availability and pricing.

All weights are estimated.

**Length Tolerances**

Set Constant (S=C Plus) HVAC POWER belts feature lengths closer matched than industry accepted match-set tolerances.

**FOR ADDITIONAL FRACTIONAL HORSEPOWER BELTS SEE PG. 27-28**

# INTRODUCTION

HIGH PERFORMANCE, MAINTENANCE-FREE

# optibelt RED POWER 3

V-BELTS, SINGLE



RED POWER 3  
V-BELTS

RED POWER 3 is a revolutionary belt that requires no maintenance throughout its lifetime, is more resistant to wear resulting in longer belt life, and transfers up to 50% more power than conventional belts. This means you will get more value and performance than you ever thought possible.

- **No-Maintenance:** No re-tensioning maintenance required throughout the belt's life.
- **More Power:** Capable of transferring up to 50% more power than conventional belts.
- **Matched-Sets:** Features OPTIBELT's S=C Plus manufacturing tolerances.
- **Shock Resistant:** Dampening qualities make it perfect for shock load applications.
- **Increased Life:** Dual wrapped fabric increases durability.
- **Greater Efficiency:** Up to 97% efficient at transferring power.
- **Temperature Range:** Increased ranges from -22 to 212°F.
- **Anti-static:** Meets ISO 1813 requirements for being anti-static.
- **Back-bend:** Flex range accommodates difficult idler stress.

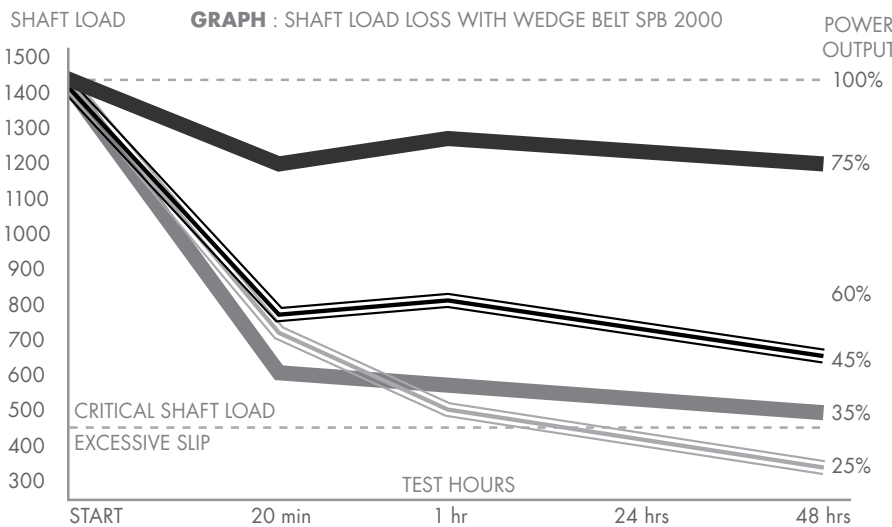

## POWER LOSS

Standard V-belts lose tension over time and require regular re-tensioning to work efficiently. Because this process is often difficult and requires machinery down-time it is not often done.

RED POWER's unique construction keeps its tension throughout its lifetime. With its added capability to transfer 50% more power and greater wear resistance RED POWER belts can save your company thousands of dollars every year.

- █ RED POWER
- ▬ PREMIUM COMPETITOR
- ▬ STANDARD COMPETITOR
- ▬ BUDGET COMPETITOR

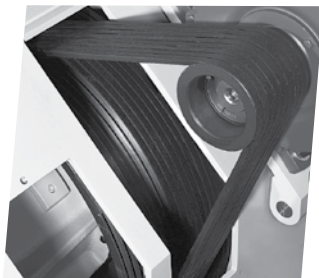

With <b>8 standard wedge belts</b>	SPB3750
Driver pulley	<b>8 grooves, 170mm dia.</b>
Driven pulley	<b>8 grooves, 900mm dia.</b>
Pulley face width	<b>6.2 Inch</b>
Theoretical belt life	25,000 hours
Re-tensioning	<b>10 times</b>

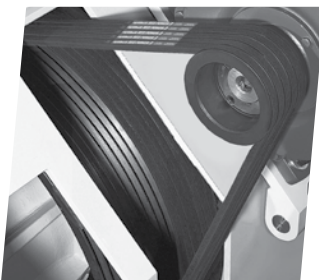

With <b>5 RED POWER</b>	SPB3750
Driver pulley	<b>5 grooves, 170mm dia.</b>
Driven pulley	<b>5 grooves, 900mm dia.</b>
Pulley face width	<b>4.7 Inch</b>
Theoretical belt life	25,000 hours
Re-tensioning	<b>None</b>

## PRACTICAL TEST

Simulated endurance test for 16 hours a day, 260 days a year, 6 year run of a feed mill pelletizer press application.

With RED POWER the results are:

- 3 fewer belts used
- No-maintenance (re-tensioning)
- Improved durability
- 35% cost savings over 6 years

**CONTACT AN OPTIBELT REPRESENTATIVE FOR MORE INFORMATION ABOUT HOW RED POWER CAN SAVE YOUR COMPANY THOUSANDS OF DOLLARS A YEAR.**



**RED POWER 3**  
CLASSIC V-BELTS

**A** SECTION : 1/2"W x 11/32"H

**CLASSIC V-BELTS**

SAMPLE PART # : ARP68

PART NO.	OUTSIDE LENGTH (IN)	WEIGHT (LBS)
ARP52	54	.32
ARP53	55	.33
ARP54	56	.34
ARP55	57	.34
ARP56	58	.35
ARP57	59	.35
ARP58	60	.36
ARP59	61	.37
ARP60	62	.37
ARP61	63	.38
ARP62	64	.38
ARP63	65	.39
ARP64	66	.40
ARP65	67	.40

PART NO.	OUTSIDE LENGTH (IN)	WEIGHT (LBS)
ARP66	68	.41
ARP67	69	.41
ARP68	70	.42
ARP69	71	.43
ARP70	72	.43
ARP71	73	.44
ARP72	74	.44
ARP73	75	.45
ARP74	76	.46
ARP75	77	.46
ARP76	78	.47
ARP77	79	.47
ARP78	80	.48
ARP79	81	.49

PART NO.	OUTSIDE LENGTH (IN)	WEIGHT (LBS)
ARP80	82	.49
ARP81	83	.50
ARP82	84	.50
ARP83	85	.51
ARP84	86	.52
ARP85	87	.52
ARP86	88	.53
ARP87	89	.53
ARP88	90	.54
ARP89	91	.55
ARP90	92	.55
ARP91	93	.56
ARP92	94	.56
ARP93	95	.57

PART NO.	OUTSIDE LENGTH (IN)	WEIGHT (LBS)
ARP94	96	.58
ARP95	97	.58
ARP96	98	.59
ARP98	100	.60
ARP100	102	.61
ARP105	107	.64
ARP110	112	.67
ARP112	114	.68
ARP120	122	.73

**B** SECTION : 21/32"W x 7/16"H

**CLASSIC V-BELTS**

SAMPLE PART # : BRP74

PART NO.	OUTSIDE LENGTH (IN)	WEIGHT (LBS)
BRP52	55	.61
BRP53	56	.62
BRP54	57	.63
BRP55	58	.64
BRP56	59	.65
BRP57	60	.66
BRP58	61	.67
BRP59	62	.68
BRP60	63	.69
BRP61	64	.70
BRP62	65	.72
BRP63	66	.73
BRP64	67	.74
BRP65	68	.75
BRP66	69	.76
BRP67	70	.77
BRP68	71	.78

PART NO.	OUTSIDE LENGTH (IN)	WEIGHT (LBS)
BRP69	72	.79
BRP70	73	.80
BRP71	74	.81
BRP72	75	.83
BRP73	76	.84
BRP74	77	.85
BRP75	78	.86
BRP76	79	.87
BRP77	80	.88
BRP78	81	.89
BRP79	82	.90
BRP80	83	.91
BRP81	84	.92
BRP82	85	.94
BRP83	86	.95
BRP84	87	.96
BRP85	88	.97

PART NO.	OUTSIDE LENGTH (IN)	WEIGHT (LBS)
BRP86	89	.98
BRP87	90	.99
BRP88	91	1.00
BRP89	92	1.01
BRP90	93	1.02
BRP91	94	1.03
BRP92	95	1.05
BRP93	96	1.06
BRP94	97	1.07
BRP95	98	1.08
BRP96	99	1.09
BRP97	100	1.10
BRP98	101	1.11
BRP99	102	1.12
BRP100	103	1.13
BRP101	104	1.14
BRP103	105	1.17

PART NO.	OUTSIDE LENGTH (IN)	WEIGHT (LBS)
BRP105	108	1.19
BRP108	111	1.22
BRP110	113	1.24
BRP111	114	1.25
BRP112	115	1.27
BRP116	119	1.31
BRP120	123	1.35
BRP123	126	1.39
BRP124	127	1.43
BRP126	129	1.42
BRP128	131	1.44
BRP130	133	1.46
BRP133	136	1.50
BRP136	139	1.56
BRP140	143	1.57
BRP144	147	1.65
BRP148	151	1.66

Contact an OPTIBELT representative regarding additional sizes, stock availability and pricing.

All weights are estimated.

Additional sizes and stocking available upon request.

**Custom Sizes & Ordering**

Section / Max. Mfg Lengths / Min. qty.

- A / 394 in. (10,000 mm) / 31
- B / 610 in. (15,500 mm) / 25

Contact customer service for details.

**S=C Length Tolerances**

Standard on all OPTIBELT single V-belts and Wedge belts 47" in length and above. S=C Plus V-belts are always superior to a matched-set regardless of the date manufactured. Not available on aramid cord, banded or cogged belts.



# 3V, 5V, 8V SECTIONS

HIGH PERFORMANCE, MAINTENANCE-FREE

# optibelt RED POWER 3

V-BELTS, SINGLE



RED POWER 3  
STANDARD V-BELTS

SAMPLE PART # : 3VRP1060

## STANDARD V-BELTS

3V SECTION : 3/8"W x 5/16"H

PART NO.	OUTSIDE LENGTH (IN)	WEIGHT (LBS)
3VRP475	47.5	.19
3VRP500	50	.20
3VRP530	53	.21
3VRP560	56	.22
3VRP600	60	.24

PART NO.	OUTSIDE LENGTH (IN)	WEIGHT (LBS)
3VRP630	63	.25
3VRP670	67	.27
3VRP710	71	.28
3VRP750	75	.30
3VRP800	80	.32

PART NO.	OUTSIDE LENGTH (IN)	WEIGHT (LBS)
3VRP850	85	.34
3VRP900	90	.36
3VRP950	95	.38
3VRP1000	100	.40
3VRP1060	106	.42

PART NO.	OUTSIDE LENGTH (IN)	WEIGHT (LBS)
3VRP1120	112	.45
3VRP1180	118	.47
3VRP1250	125	.50
3VRP1320	132	.53
3VRP1400	140	.56

SAMPLE PART # : 5VRP900

## STANDARD V-BELTS

5V SECTION : 5/8"W x 17/32"H

PART NO.	OUTSIDE LENGTH (IN)	WEIGHT (LBS)
5VRP500	50	.55
5VRP530	53	.58
5VRP560	56	.62
5VRP600	60	.66
5VRP630	63	.69
5VRP670	67	.74
5VRP710	71	.78
5VRP750	75	.83
5VRP800	80	.88

PART NO.	OUTSIDE LENGTH (IN)	WEIGHT (LBS)
5VRP850	85	.94
5VRP900	90	.99
5VRP950	95	1.05
5VRP1000	100	1.10
5VRP1060	106	1.17
5VRP1120	112	1.23
5VRP1180	118	1.30
5VRP1250	125	1.38
5VRP1320	132	1.45

PART NO.	OUTSIDE LENGTH (IN)	WEIGHT (LBS)
5VRP1400	140	1.54
5VRP1500	150	1.65
5VRP1600	160	1.76
5VRP1700	170	1.87
5VRP1800	180	1.98
5VRP1900	190	2.09
5VRP2000	200	2.20
5VRP2120	212	2.33
5VRP2240	224	2.46

PART NO.	OUTSIDE LENGTH (IN)	WEIGHT (LBS)
5VRP2360	236	2.60
5VRP2500	250	2.75
5VRP2650	265	2.92
5VRP2800	280	3.08
5VRP3000	300	3.30
5VRP3150	315	3.47

SAMPLE PART # : 8VRP2800

## STANDARD V-BELTS

8V SECTION : 1"W x 7/8"H

PART NO.	OUTSIDE LENGTH (IN)	WEIGHT (LBS)
8VRP1000	100	3.20
8VRP1060	106	3.39
8VRP1120	112	3.58
8VRP1180	118	3.78
8VRP1250	125	4.00
8VRP1320	132	4.22

PART NO.	OUTSIDE LENGTH (IN)	WEIGHT (LBS)
8VRP1400	140	4.48
8VRP1500	150	4.80
8VRP1600	160	5.12
8VRP1700	170	5.44
8VRP1800	180	5.76
8VRP1900	190	6.08

PART NO.	OUTSIDE LENGTH (IN)	WEIGHT (LBS)
8VRP2000	200	6.40
8VRP2120	212	6.78
8VRP2240	224	7.17
8VRP2360	236	7.55
8VRP2500	250	8.00
8VRP2650	265	8.48

PART NO.	OUTSIDE LENGTH (IN)	WEIGHT (LBS)
8VRP2800	280	8.96
8VRP3000	300	9.60
8VRP3150	315	10.00
8VRP3350	335	10.72
8VRP3550	355	11.36

### NEED A CUSTOM LENGTH?

Because of OPTIBELT's Rotary Vulcanization process, you will be able to get a custom length without the custom mold surcharge.

### DID YOU KNOW?

OPTIBELT's Set-Constant (S=C Plus) length tolerance makes your multiple belt drive run more efficiently. No other manufacturer can match OPTIBELT's precision

### BELTS FAILING?

Do you have old design, difficult idler placement or something entirely unique? Give Red Power a try. Its unique construction has solved many customer's difficult issues.

#### S=C Length Tolerances

Standard on all OPTIBELT single V-belts and Wedge belts 47" in length and above. S=C Plus V-belts are always superior to a matched-set regardless of the date manufactured. Not available on aramid cord, banded or cogged belts.

#### Custom Sizes & Ordering

Section / Max. Mfg Lengths / Min. qty.  
 • 3V / 157 in. / 40  
 • 5V / 492 in. / 25  
 • 8V / 492 in. / 14  
 Contact customer service for details.

OPTIBELT representative regarding additional sizes, stock availability and pricing.

All weights are estimated.

Additional sizes and stocking available.



**SPZ** SECTION : 9.7mm W x 8mm H

**METRIC V-BELTS**

SAMPLE PART # : SPZRP1537

PART NO.	DATUM LENGTH (MM)	WEIGHT (LBS)
SPZRP1202	1202	.89
SPZRP1212	1212	.90
SPZRP1237	1237	.92
SPZRP1250	1250	.93
SPZRP1262	1262	.93
SPZRP1287	1287	.95
SPZRP1312	1312	.97
SPZRP1320	1320	.98
SPZRP1347	1337	.99
SPZRP1362	1362	1.01
SPZRP1387	1387	1.03
SPZRP1400	1400	1.04
SPZRP1412	1412	1.04

PART NO.	DATUM LENGTH (MM)	WEIGHT (LBS)
SPZRP1437	1437	1.06
SPZRP1462	1462	1.08
SPZRP1487	1487	1.10
SPZRP1500	1500	1.11
SPZRP1512	1512	1.12
SPZRP1537	1537	1.14
SPZRP1562	1562	1.16
SPZRP1587	1587	1.17
SPZRP1600	1600	1.18
SPZRP1612	1612	1.19
SPZRP1637	1637	1.21
SPZRP1662	1662	1.23
SPZRP1687	1687	1.25

PART NO.	DATUM LENGTH (MM)	WEIGHT (LBS)
SPZRP1700	1700	1.26
SPZRP1737	1737	1.29
SPZRP1762	1762	1.30
SPZRP1787	1787	1.32
SPZRP1800	1800	1.33
SPZRP1837	1837	1.36
SPZRP1862	1862	1.38
SPZRP1887	1887	1.40
SPZRP1900	1900	1.41
SPZRP1937	1937	1.43
SPZRP1987	1987	1.47
SPZRP2000	2000	1.48
SPZRP2037	2037	1.51

PART NO.	DATUM LENGTH (MM)	WEIGHT (LBS)
SPZRP2120	2120	1.57
SPZRP2137	2137	1.58
SPZRP2187	2187	1.62
SPZRP2240	2240	1.66
SPZRP2287	2287	1.69
SPZRP2360	2360	1.75
SPZRP2500	2500	1.85
SPZRP2650	2650	1.96
SPZRP2800	2800	2.07
SPZRP3000	3000	2.22
SPZRP3150	3150	2.33
SPZRP3350	3350	2.48
SPZRP3550	3550	2.63

**SPZ CONVERSION:** OUTSIDE LENGTH = DATUM LENGTH +13mm

**SPA** SECTION : 12.7mm W x 10mm H

**METRIC V-BELTS**

SAMPLE PART # : SPARP1632

PART NO.	DATUM LENGTH (MM)	WEIGHT (LBS)
SPARP1207	1207	1.48
SPARP1232	1232	1.52
SPARP1250	1250	1.54
SPARP1257	1257	1.55
SPARP1282	1282	1.58
SPARP1307	1307	1.61
SPARP1320	1320	1.62
SPARP1332	1332	1.64
SPARP1357	1357	1.67
SPARP1382	1382	1.70
SPARP1400	1400	1.72
SPARP1407	1407	1.73
SPARP1432	1432	1.76
SPARP1457	1457	1.79
SPARP1482	1482	1.82
SPARP1500	1500	1.85
SPARP1507	1507	1.85
SPARP1532	1532	1.88
SPARP1557	1557	1.92
SPARP1582	1582	1.95
SPARP1600	1600	1.97

PART NO.	DATUM LENGTH (MM)	WEIGHT (LBS)
SPARP1607	1607	1.98
SPARP1632	1632	2.01
SPARP1657	1657	2.04
SPARP1682	1682	2.07
SPARP1700	1700	2.09
SPARP1707	1707	2.10
SPARP1732	1732	2.13
SPARP1757	1757	2.16
SPARP1782	1782	2.19
SPARP1800	1800	2.21
SPARP1807	1807	2.22
SPARP1832	1832	2.25
SPARP1857	1857	2.28
SPARP1882	1882	2.31
SPARP1900	1900	2.34
SPARP1907	1907	2.35
SPARP1932	1932	2.38
SPARP1957	1957	2.41
SPARP1982	1982	2.44
SPARP2000	2000	2.46
SPARP2032	2032	2.50

PART NO.	DATUM LENGTH (MM)	WEIGHT (LBS)
SPARP2057	2057	2.53
SPARP2082	2082	2.56
SPARP2120	2120	2.61
SPARP2132	2132	2.62
SPARP2182	2182	2.68
SPARP2207	2207	2.71
SPARP2232	2232	2.75
SPARP2240	2240	2.76
SPARP2282	2282	2.81
SPARP2300	2300	2.83
SPARP2307	2307	2.84
SPARP2332	2332	2.87
SPARP2360	2360	2.90
SPARP2382	2382	2.93
SPARP2432	2432	2.99
SPARP2482	2482	3.05
SPARP2500	2500	3.08
SPARP2532	2532	3.11
SPARP2582	2582	3.18
SPARP2607	2607	3.21
SPARP2632	2632	3.24

PART NO.	DATUM LENGTH (MM)	WEIGHT (LBS)
SPARP2650	2650	3.26
SPARP2682	2682	3.30
SPARP2732	2732	3.36
SPARP2782	2782	3.42
SPARP2800	2800	3.44
SPARP2832	2832	3.48
SPARP2847	2847	3.50
SPARP2882	2882	3.54
SPARP2932	2932	3.61
SPARP2982	2982	3.67
SPARP3000	3000	3.69
SPARP3032	3032	3.73
SPARP3082	3082	3.79
SPARP3150	3150	3.87
SPARP3182	3182	3.91
SPARP3282	3282	4.04
SPARP3350	3350	4.12
SPARP3382	3382	4.16
SPARP3550	3550	4.37
SPARP3750	3750	4.61
SPARP4000	4000	4.92

**SPA CONVERSION:** OUTSIDE LENGTH = DATUM LENGTH +18mm

**Custom Sizes & Ordering**

Section / Max. Mfg Lengths / Min. qty.

- SPZ / 158 in. (4,000 mm) / 120
- SPA / 158 in. (4,000 mm) / 95

Contact customer service for details.

Contact an OPTIBELT representative regarding additional sizes, stock availability and pricing.

All weights are estimated.

Additional sizes and stocking available.

**S=C Length Tolerances**

Standard on all OPTIBELT single V-belts and Wedge belts 47" in length and above. S=C Plus V-belts are always superior to a matched-set regardless of the date manufactured. Not available on aramid cord, banded or cogged belts.



SAMPLE PART # : SPBRP1600

**METRIC V-BELTS**

**SPB** SECTION : 16.3mm W x 13mm H

PART NO.	DATUM LENGTH (MM)	WEIGHT (LBS)
SPBRP1250	1250	2.44
SPBRP1320	1320	2.57
SPBRP1400	1400	2.73
SPBRP1500	1500	2.93
SPBRP1600	1600	3.12
SPBRP1700	1700	3.32
SPBRP1800	1800	3.51
SPBRP1900	1900	3.71
SPBRP2000	2000	3.90

PART NO.	DATUM LENGTH (MM)	WEIGHT (LBS)
SPBRP2120	2120	4.13
SPBRP2240	2240	4.37
SPBRP2360	2360	4.60
SPBRP2500	2500	4.88
SPBRP2650	2650	5.17
SPBRP2800	2800	5.46
SPBRP3000	3000	5.85
SPBRP3150	3150	6.14
SPBRP3350	3350	6.53

PART NO.	DATUM LENGTH (MM)	WEIGHT (LBS)
SPBRP3550	3550	6.92
SPBRP3750	3750	7.31
SPBRP4000	4000	7.80
SPBRP4250	4250	8.29
SPBRP4500	4500	8.78
SPBRP4750	4750	9.26
SPBRP5000	5000	9.75
SPBRP5300	5300	10.34
SPBRP5600	5600	10.92

PART NO.	DATUM LENGTH (MM)	WEIGHT (LBS)
SPBRP6000	6000	11.70
SPBRP6300	6300	12.29
SPBRP6700	6700	13.07
SPBRP7100	7100	13.85
SPBRP7500	7500	14.63
SPBRP8000	8000	15.60

**SPB CONVERSION:** OUTSIDE LENGTH = DATUM LENGTH +22mm

SAMPLE PART # : SPCRP4750

**METRIC V-BELTS**

**SPC** SECTION : 22mm W x 18mm H

PART NO.	DATUM LENGTH (MM)	WEIGHT (LBS)
SPCRP2000	2000	7.54
SPCRP2120	2120	7.99
SPCRP2240	2240	8.44
SPCRP2360	2360	8.90
SPCRP2500	2500	9.43
SPCRP2650	2650	9.99
SPCRP2800	2800	10.56

PART NO.	DATUM LENGTH (MM)	WEIGHT (LBS)
SPCRP3000	3000	11.31
SPCRP3150	3150	11.88
SPCRP3350	3350	12.63
SPCRP3550	3550	13.38
SPCRP3750	3750	14.14
SPCRP4000	4000	15.08
SPCRP4250	4250	16.02

PART NO.	DATUM LENGTH (MM)	WEIGHT (LBS)
SPCRP4500	4500	16.97
SPCRP4750	4750	17.91
SPCRP5000	5000	18.85
SPCRP5300	5300	19.98
SPCRP5600	5600	21.11
SPCRP6000	6000	22.62
SPCRP6300	6300	23.75

PART NO.	DATUM LENGTH (MM)	WEIGHT (LBS)
SPCRP6700	6700	25.26
SPCRP7100	7100	26.77
SPCRP7500	7500	28.28
SPCRP8000	8000	30.16

**SPC CONVERSION:** OUTSIDE LENGTH = DATUM LENGTH +30mm

**CUSTOMER SERVICE**

**800-292-6081**  
INFO@OPTIBELT-USA.COM

**DID YOU KNOW?**

OPTIBELT's Set-Constant (S=C Plus) length tolerance makes your multiple belt drive run more efficiently. No other manufacturer can match OPTIBELT's precision.

**DRIVE PROBLEMS?**

Do you have old design, difficult idler placement or something entirely unique? Give Red Power a try. Its unique construction has solved many customer's difficult issues.



**NEED SHEAVES? SEE PAGE 133-139**

**124 KS SHEAVES, METRIC**

- 124-125 SECTIONS: SPZ/10
- 126-127 SECTIONS: SPA/13
- 128-130 SECTIONS: SPB/17
- 131-132 SECTIONS: SPC/22

**S=C Length Tolerances**

Standard on all OPTIBELT single V-belts and Wedge belts 47" in length and above. S=C Plus V-belts are always superior to a matched-set regardless of the date manufactured. Not available on aramid cord, banded or cogged belts.

**Custom Sizes & Ordering**

Section / Max. Mfg Lengths / Min. qty.  
 • SPB / 475 in. (12,500 mm) / 36  
 • SPC / 475 in. (12,500 mm) / 16  
 Contact customer service for details.

Contact an OPTIBELT representative regarding additional sizes, stock availability and pricing.

All weights are estimated.

Additional sizes and stocking available.



VB  
CLASSIC V-BELTS

**A SECTION : 1/2"W x 11/32"H**

**CLASSIC V-BELTS**

SAMPLE PART # : A90

PART NO.	OUTSIDE LENGTH (IN)	WEIGHT (LBS)
A20	22	.13
A21	23	.14
A22	24	.14
A23	25	.15
A24	26	.16
A25	27	.16
A26	28	.17
A27	29	.17
A28	30	.18
A29	31	.19
A30	32	.19
A31	33	.20
A32	34	.20
A33	35	.21
A34	36	.22
A35	37	.22
A36	38	.23
A37	39	.23
A38	40	.24
A39	41	.25
A40	42	.25
A41	43	.26
A42	44	.26
A43	45	.27
A44	46	.28
A45	47	.28

PART NO.	OUTSIDE LENGTH (IN)	WEIGHT (LBS)
A46	48	.29
A47	49	.29
A48	50	.30
A49	51	.31
A50	52	.31
A51	53	.32
A52	54	.32
A53	55	.33
A54	56	.34
A55	57	.34
A56	58	.35
A57	59	.35
A58	60	.36
A59	61	.37
A60	62	.37
A61	63	.38
A62	64	.38
A63	65	.39
A64	66	.40
A65	67	.40
A66	68	.41
A67	69	.41
A68	70	.42
A69	71	.43
A70	72	.43
A71	73	.44

PART NO.	OUTSIDE LENGTH (IN)	WEIGHT (LBS)
A72	74	.44
A73	75	.45
A74	76	.46
A75	77	.46
A76	78	.47
A77	79	.47
A78	80	.48
A79	81	.49
A80	82	.49
A81	83	.50
A82	84	.50
A83	85	.51
A84	86	.52
A85	87	.52
A86	88	.53
A87	89	.53
A88	90	.54
A89	91	.55
A90	92	.55
A91	93	.56
A92	94	.56
A93	95	.57
A94	96	.58
A95	97	.58
A96	98	.59
A97	99	.59

PART NO.	OUTSIDE LENGTH (IN)	WEIGHT (LBS)
A98	100	.60
A99	101	.61
A100	102	.61
A101	103	.62
A102	104	.62
A103	105	.63
A105	107	.64
A110	112	.67
A112	114	.68
A114	116	.70
A115	117	.71
A120	122	.73
A124	126	.76
A125	127	.76
A128	130	.78
A133	135	.81
A136	138	.83
A140	142	.85
A144	146	.88
A155	157	.94
A158	160	.96
A173	175	1.05
A180	182	1.09

**DON'T SEE A SIZE YOU NEED?**  
WE HAVE IT! CONTACT AN OPTIBELT REPRESENTATIVE FOR INFORMATION.

**B SECTION : 21/32"W x 7/16"H**

**CLASSIC V-BELTS**

SAMPLE PART # : B50

PART NO.	OUTSIDE LENGTH (IN)	WEIGHT (LBS)
B23	26	.29
B24	27	.30
B25	28	.31
B26	29	.32
B27	30	.33
B28	31	.34
B29	32	.35
B30	33	.36
B31	34	.37

PART NO.	OUTSIDE LENGTH (IN)	WEIGHT (LBS)
B32	35	.39
B33	36	.40
B34	37	.41
B35	38	.42
B36	39	.43
B37	40	.44
B38	41	.45
B39	42	.46
B40	43	.47

PART NO.	OUTSIDE LENGTH (IN)	WEIGHT (LBS)
B41	44	.48
B42	45	.50
B43	46	.51
B44	47	.52
B45	48	.53
B46	49	.54
B47	50	.55
B48	51	.56
B49	52	.57

PART NO.	OUTSIDE LENGTH (IN)	WEIGHT (LBS)
B50	53	.58
B51	54	.59
B52	55	.61
B53	56	.62
B54	57	.63
B55	58	.64
B56	59	.65

**B SECTIONS CONTINUED PG 19**

Contact an OPTIBELT representative regarding additional sizes, stock availability and pricing.

All weights are estimated.

Additional sizes and stocking available.

**Custom Sizes & Ordering**

Section / Max. Mfg Lengths / Min. qty.

- A / 394 in. (10,000 mm) / 31
- B / 985 in. (25,000 mm) / 25

Contact customer service for details.

**S=C Length Tolerances**

Standard on all OPTIBELT single V-belts and Wedge belts 47" in length and above. S=C Plus V-belts are always superior to a matched-set regardless of the date manufactured. Not available on aramid cord, banded or cogged belts.



SAMPLE PART # : B138

**CLASSIC V-BELTS**

**B** SECTION : 21/32"W x 7/16"H

PART NO.	OUTSIDE LENGTH (IN)	WEIGHT (LBS)
B57	60	.66
B58	61	.67
B59	62	.68
B60	63	.69
B61	64	.70
B62	65	.72
B63	66	.73
B64	67	.74
B65	68	.75
B66	69	.76
B67	70	.77
B68	71	.78
B69	72	.79
B70	73	.80
B71	74	.81
B72	75	.83
B73	76	.84
B74	77	.85
B75	78	.86
B76	79	.87
B77	80	.88
B78	81	.89
B79	82	.90
B80	83	.91
B81	84	.92
B82	85	.94
B83	86	.95

PART NO.	OUTSIDE LENGTH (IN)	WEIGHT (LBS)
B84	87	.96
B85	88	.97
B86	89	.98
B87	90	.99
B88	91	1.00
B89	92	1.01
B90	93	1.02
B91	94	1.03
B92	95	1.05
B93	96	1.06
B94	97	1.07
B95	98	1.08
B96	99	1.09
B97	100	1.10
B98	101	1.11
B99	102	1.12
B100	103	1.13
B101	104	1.14
B102	105	1.16
B103	106	1.17
B104	107	1.18
B105	108	1.19
B106	109	1.20
B108	111	1.22
B109	112	1.23
B110	113	1.24
B111	114	1.25

PART NO.	OUTSIDE LENGTH (IN)	WEIGHT (LBS)
B112	115	1.27
B113	116	1.28
B114	117	1.29
B115	118	1.30
B116	119	1.31
B118	121	1.33
B120	123	1.35
B123	126	1.39
B124	127	1.40
B126	129	1.42
B128	131	1.44
B130	133	1.46
B131	134	1.47
B132	135	1.49
B133	136	1.50
B135	138	1.52
B136	139	1.53
B138	141	1.55
B140	143	1.57
B141	144	1.58
B142	145	1.60
B144	147	1.62
B146	149	1.64
B148	151	1.66
B150	153	1.68
B152	155	1.71
B153	156	1.72

PART NO.	OUTSIDE LENGTH (IN)	WEIGHT (LBS)
B154	157	1.73
B156	159	1.75
B158	161	1.77
B160	163	1.79
B162	165	1.82
B173	176	1.94
B180	183	2.01
B184	187	2.06
B188	191	2.10
B190	193	2.12
B195	198	2.18
B199	202	2.22
B205	208	2.29
B210	213	2.34
B221	224	2.46
B225	228	2.51
B230	233	2.56
B236	239	2.63
B240	243	2.67
B255	258	2.84
B270	273	3.00
B285	288	3.17
B300	303	3.33
B315	318	3.50
B345	348	3.83
B360	363	3.99

SAMPLE PART # : C72

**CLASSIC V-BELTS**

**C** SECTION : 7/8"W x 9/16"H

PART NO.	OUTSIDE LENGTH (IN)	WEIGHT (LBS)
C47	51	.92
C48	52	.94
C51	55	.99
C54	58	1.04
C55	59	1.06
C57	61	1.10
C60	64	1.15
C62	66	1.19

PART NO.	OUTSIDE LENGTH (IN)	WEIGHT (LBS)
C63	67	1.21
C64	68	1.22
C65	69	1.24
C66	70	1.26
C68	72	1.30
C70	74	1.33
C71	75	1.35
C72	76	1.37

PART NO.	OUTSIDE LENGTH (IN)	WEIGHT (LBS)
C73	77	1.39
C74	78	1.40
C75	79	1.42
C76	80	1.44
C78	82	1.48
C79	83	1.49
C80	84	1.51
C81	85	1.53

PART NO.	OUTSIDE LENGTH (IN)	WEIGHT (LBS)
C82	86	1.55
C83	87	1.57
C85	89	1.60
C86	90	1.60
C88	92	1.66
C90	94	1.69

**C SECTIONS CONTINUED PG 20**

**S=C Length Tolerances**  
Standard on all OPTIBELT single V-belts and Wedge belts 47" in length and above. S=C Plus V-belts are always superior to a matched-set regardless of the date manufactured. Not available on aramid cord, banded or cogged belts.

**Custom Sizes & Ordering**  
Section / Max. Mfg Lengths / Min. qty.  
 • B / 827 in. (21,000 mm) / 25  
 • C / 827 in. (21,000 mm) / 19  
 Contact customer service for details.

Contact an OPTIBELT representative regarding additional sizes, stock availability and pricing.  
 All weights are estimated.  
 Additional sizes and stocking available.



VB  
CLASSIC V-BELTS

**C SECTION : 7/8"W x 9/16"H**

**CLASSIC V-BELTS**

SAMPLE PART # : C285

PART NO.	OUTSIDE LENGTH (IN)	WEIGHT (LBS)
C92	96	1.73
C93	97	1.75
C94	98	1.76
C96	100	1.80
C97	101	1.82
C98	102	1.84
C99	103	1.85
C100	104	1.87
C101	105	1.89
C103	107	1.93
C105	109	1.96
C106	110	1.98
C107	111	2.00
C108	112	2.02
C109	113	2.03
C110	114	2.05
C111	115	2.07
C112	116	2.09

PART NO.	OUTSIDE LENGTH (IN)	WEIGHT (LBS)
C114	118	2.12
C115	119	2.14
C117	121	2.18
C120	124	2.23
C122	126	2.27
C124	128	2.3
C126	130	2.34
C128	132	2.38
C131	135	2.43
C132	136	2.45
C134	138	2.48
C136	140	2.52
C138	142	2.56
C140	144	2.59
C141	145	2.61
C144	148	2.66
C147	151	2.72
C148	152	2.74

PART NO.	OUTSIDE LENGTH (IN)	WEIGHT (LBS)
C150	154	2.77
C151	155	2.79
C154	158	2.84
C156	160	2.88
C158	162	2.92
C162	166	2.99
C165	169	3.04
C169	173	3.11
C170	174	3.13
C173	177	3.19
C175	179	3.22
C177	181	3.26
C180	184	3.31
C183	187	3.37
C185	189	3.40
C188	192	3.46
C190	194	3.49
C195	199	3.58

PART NO.	OUTSIDE LENGTH (IN)	WEIGHT (LBS)
C210	214	3.85
C214	218	3.89
C225	229	4.09
C235	239	4.27
C240	244	4.36
C246	250	4.46
C255	259	4.63
C270	274	4.90
C285	289	5.17
C300	304	5.44
C315	319	5.71
C330	334	5.98
C345	349	6.25
C360	364	6.52
C390	394	7.06
C420	424	7.6

**D SECTION : 1-1/4"W x 3/4"H**

**CLASSIC V-BELTS**

SAMPLE PART # : D128

PART NO.	OUTSIDE LENGTH (IN)	WEIGHT (LBS)
D105	110	4.18
D112	117	4.45
D120	125	4.75
D128	133	5.05
D140	145	5.51
D144	149	5.66
D158	163	6.19

PART NO.	OUTSIDE LENGTH (IN)	WEIGHT (LBS)
D162	167	6.35
D173	178	6.76
D180	185	7.03
D195	200	7.60
D210	215	8.17
D225	230	8.66
D240	245	9.23

PART NO.	OUTSIDE LENGTH (IN)	WEIGHT (LBS)
D255	260	9.80
D270	275	10.37
D285	290	10.94
D300	305	11.51
D315	320	12.08
D330	335	12.73
D345	350	13.22

PART NO.	OUTSIDE LENGTH (IN)	WEIGHT (LBS)
D360	365	13.79
D390	395	14.93
D420	425	16.07
D450	455	17.21
D480	485	18.35
D540	545	20.63

**E SECTION : 1-1/2" W x 1" H**

**CLASSIC V-BELTS**

SAMPLE PART # : E420

PART NO.	OUTSIDE LENGTH (IN)	WEIGHT (LBS)
E180	187	10.85
E195	202	11.72
E210	217	12.59
E240	247	14.15

PART NO.	OUTSIDE LENGTH (IN)	WEIGHT (LBS)
E270	277	15.89
E300	307	17.63
E330	337	19.37
E360	367	21.11

PART NO.	OUTSIDE LENGTH (IN)	WEIGHT (LBS)
E390	397	22.85
E420	427	24.59
E448	455	26.22

PART NO.	OUTSIDE LENGTH (IN)	WEIGHT (LBS)
E480	487	28.07
E540	547	31.55
E600	607	35.03

Contact an OPTIBELT representative regarding additional sizes, stock availability and pricing.

All weights are estimated.

Additional sizes and stocking available upon request

**Custom Sizes & Ordering**

Section / Max. Mfg Lengths / Min. qty.

- C / 827 in. (21,000 mm) / 19
- D / 827 in. (21,000 mm) / 11
- E / 827 in. (21,000 mm) / 7

Contact customer service for details.

**S=C Length Tolerances**

Standard on all OPTIBELT single V-belts and Wedge belts 47" in length and above. S=C Plus V-belts are always superior to a matched-set regardless of the date manufactured. Not available on aramid cord, banded or cogged belts.



SAMPLE PART # : 5X475

**METRIC V-BELTS**

**5** SECTION : 5mm W x 3mm H

PART NO.	INSIDE LENGTH (MM)	DATUM LENGTH (MM)	WEIGHT (LBS)
• 5X190	190	200	.01
• 5X229	229	239	.01
• 5X260	260	270	.01
• 5X280	280	290	.01
• 5X300	300	310	.01

PART NO.	INSIDE LENGTH (MM)	DATUM LENGTH (MM)	WEIGHT (LBS)
• 5X315	315	325	.01
• 5X322	322	332	.01
• 5X335	335	345	.01
• 5X375	375	385	.02
• 5X425	425	435	.02

PART NO.	INSIDE LENGTH (MM)	DATUM LENGTH (MM)	WEIGHT (LBS)
• 5X475	475	485	.02
• 5X500	500	510	.02
• 5X530	530	540	.02
• 5X554	554	564	.02
• 5X600	600	610	.02

SAMPLE PART # : 6X335

**METRIC V-BELTS**

**6** SECTION : 6mm W x 4mm H

PART NO.	INSIDE LENGTH (MM)	DATUM LENGTH (MM)	WEIGHT (LBS)
• 6X280	280	295	.02
• 6X300	300	315	.02
• 6X335	335	350	.02
• 6X400	400	415	.02

PART NO.	INSIDE LENGTH (MM)	DATUM LENGTH (MM)	WEIGHT (LBS)
• 6X425	425	440	.02
• 6X450	450	465	.03
• 6X500	500	515	.03

PART NO.	INSIDE LENGTH (MM)	DATUM LENGTH (MM)	WEIGHT (LBS)
• 6X540	540	555	.03
• 6X600	600	615	.04
• 6X850	850	865	.05

SAMPLE PART # : 8X560

**METRIC V-BELTS**

**8** SECTION : 8mm W x 5mm H

PART NO.	INSIDE LENGTH (MM)	DATUM LENGTH (MM)	WEIGHT (LBS)
• 8X315	315	335	.03
• 8X355	355	375	.03
• 8X400	400	420	.04
• 8X425	425	445	.04
• 8X450	450	470	.04
• 8X475	475	495	.04
• 8X490	490	510	.05
• 8X530	530	550	.05
• 8X560	560	580	.05
• 8X575	575	595	.05

PART NO.	INSIDE LENGTH (MM)	DATUM LENGTH (MM)	WEIGHT (LBS)
• 8X600	600	620	.06
• 8X630	630	650	.06
• 8X670	670	690	.06
• 8X700	700	720	.06
• 8X710	710	730	.07
• 8X750	750	770	.07
• 8X775	775	795	.07
8X800	800	820	.07
8X825	825	845	.08
8X850	850	870	.08

PART NO.	INSIDE LENGTH (MM)	DATUM LENGTH (MM)	WEIGHT (LBS)
8X875	875	895	.08
8X900	900	920	.08
8X950	950	970	.09
8X1000	1000	1020	.09
8X1020	1020	1040	.09
8X1050	1050	1070	0.10
8X1075	1075	1095	0.10
8X1120	1120	1140	0.10
8X1200	1200	1220	0.11
8X1250	1250	1270	0.12

**NEED A CUSTOM LENGTH?**

Because of OPTIBELT's precision manufacturing processes, you will be able to order a custom length without a surcharge. Some restrictions apply. Contact an OPTIBELT representative for more details.

**S=C Length Tolerances**

Standard on all OPTIBELT single V-belts and Wedge belts 47" in length and above. S=C Plus V-belts are always superior to a matched-set regardless of the date manufactured. Not available on aramid cord, banded or cogged belts.

**Custom Sizes & Ordering**

Maximum manufacturing length: 4500 mm  
Minimum production quantity applies.  
Contact customer service for details.

**• INDICATES RAW EDGE MOLDED COGGED**

Contact an OPTIBELT representative regarding additional sizes, stock availability and pricing.  
All weights are estimated.  
Additional sizes and stocking available.



**10** SECTION : 10mm W x 6mm H

**METRIC V-BELTS**

SAMPLE PART # : 10X475

PART NO.	INSIDE LENGTH (MM)	DATUM LENGTH (MM)	WEIGHT (LBS)
• 10X290	290	312	.04
• 10X315	315	337	.04
• 10X375	375	397	.05
• 10X400	400	422	.05
• 10X425	425	447	.06
• 10X450	450	472	.06
• 10X475	475	497	.06
• 10X480	480	502	.06
• 10X500	500	522	.07
• 10X515	515	537	.07
• 10X525	525	547	.07
• 10X530	530	552	.07
• 10X540	540	562	.07
• 10X560	560	582	.07
10X575	575	597	.08
10X600	600	622	.09
10X630	630	652	.09
10X650	650	672	.09
10X670	670	692	.10
10X700	700	722	.10
10X710	710	732	.10
10X725	725	747	.10
10X730	730	752	.10
10X750	750	772	.11
10X765	765	787	.11
10X775	775	797	.11
10X800	800	822	.11
10X820	820	842	.12

PART NO.	INSIDE LENGTH (MM)	DATUM LENGTH (MM)	WEIGHT (LBS)
10X825	825	847	.12
10X850	850	872	.12
10X865	865	887	.12
10X875	875	897	.13
10X900	900	922	.13
10X925	925	947	.13
10X950	950	972	.14
10X975	975	997	.14
10X1000	1000	1022	.14
10X1016	1016	1038	.15
10X1030	1030	1052	.15
10X1041	1041	1063	.15
10X1050	1050	1072	.15
10X1060	1060	1082	.15
10X1080	1080	1102	.15
10X1100	1100	1122	.16
10X1120	1120	1142	.16
10X1150	1150	1172	.17
10X1165	1165	1187	.17
10X1180	1180	1202	.17
10X1194	1194	1216	.17
10X1215	1215	1237	.17
10X1225	1225	1247	.18
10X1250	1250	1272	.18
10X1270	1270	1292	.18
10X1295	1295	1317	.18
10X1320	1320	1342	.19
10X1346	1346	1368	.19

PART NO.	INSIDE LENGTH (MM)	DATUM LENGTH (MM)	WEIGHT (LBS)
10X1371	1371	1393	.20
10X1400	1400	1422	.20
10X1422	1422	1444	.20
10X1450	1450	1472	.21
10X1475	1475	1497	.21
10X1500	1500	1522	.22
10X1524	1524	1546	.22
10X1550	1550	1572	.22
10X1575	1575	1597	.22
10X1600	1600	1622	.23
10X1626	1626	1648	.23
10X1651	1651	1673	.24
10X1675	1675	1697	.24
10X1700	1700	1722	.24
10X1725	1725	1747	.25
10X1750	1750	1772	.25
10X1775	1775	1797	.25
10X1800	1800	1822	.26
10X1850	1850	1872	.26
10X1900	1900	1922	.27
10X1975	1975	1997	.28
10X2000	2000	2022	.29
10X2120	2120	2142	.30
10X2240	2240	2262	.32
10X2360	2360	2382	.34
10X2500	2500	2522	.36

**NEED A CUSTOM LENGTH?**

Because of OPTIBELT's precision manufacturing processes, you will be able to order a custom length without a surcharge. Some restrictions apply. Contact an OPTIBELT representative for more details.

**• INDICATES RAW EDGE MOLDED COGGED**

Contact an OPTIBELT representative regarding additional sizes, stock availability and pricing.

All weights are estimated.

Additional sizes and stocking available.

**Custom Sizes & Ordering**

Maximum manufacturing length: 4500 mm

Minimum production quantity applies.

Contact customer service for details.

**S=C Length Tolerances**

Standard on all OPTIBELT single V-belts and Wedge belts 47" in length and above. S=C Plus V-belts are always superior to a matched-set regardless of the date manufactured. Not available on aramid cord, banded or cogged belts.



# 3V, 5V & 8V SECTIONS

S=C PLUS LENGTH TOLERANCES

**optibelt SK**  
V-BELTS, SINGLE



STANDARD V-BELTS  
**SK**

SAMPLE PART # : 3V1060

## STANDARD V-BELTS

**3V** SECTION : 3/8"W x 5/16"H

PART NO.	OUTSIDE LENGTH (IN)	WEIGHT (LBS)
3V250	25	.10
3V265	26.5	.11
3V280	28	.11
3V300	30	.12
3V315	31.5	.13
3V335	33.5	.13
3V355	35.5	.14
3V375	37.5	.15

PART NO.	OUTSIDE LENGTH (IN)	WEIGHT (LBS)
3V400	40	.16
3V425	42.5	.17
3V450	45	.18
3V475	47.5	.19
3V500	50	.20
3V530	53	.21
3V560	56	.22
3V600	60	.24

PART NO.	OUTSIDE LENGTH (IN)	WEIGHT (LBS)
3V630	63	.25
3V670	67	.27
3V710	71	.28
3V750	75	.30
3V800	80	.32
3V830	83	.33
3V850	85	.34
3V900	90	.36

PART NO.	OUTSIDE LENGTH (IN)	WEIGHT (LBS)
3V950	95	.38
3V1000	100	.40
3V1060	106	.42
3V1120	112	.45
3V1180	118	.47
3V1250	125	.50
3V1320	132	.53
3V1400	140	.56

SAMPLE PART # : 5V900

## STANDARD V-BELTS

**5V** SECTION : 5/8"W x 17/32"H

PART NO.	OUTSIDE LENGTH (IN)	WEIGHT (LBS)
5V500	50	.55
5V530	53	.58
5V560	56	.62
5V600	60	.66
5V630	63	.69
5V670	67	.74
5V710	71	.78
5V750	75	.83
5V800	80	.88

PART NO.	OUTSIDE LENGTH (IN)	WEIGHT (LBS)
5V850	85	.94
5V900	90	.99
5V950	95	1.05
5V1000	100	1.10
5V1060	106	1.17
5V1080	108	1.19
5V1120	112	1.23
5V1180	118	1.30
5V1250	125	1.38

PART NO.	OUTSIDE LENGTH (IN)	WEIGHT (LBS)
5V1320	132	1.45
5V1400	140	1.54
5V1500	150	1.65
5V1600	160	1.76
5V1700	170	1.87
5V1800	180	1.98
5V1900	190	2.09
5V2000	200	2.20
5V2120	212	2.33

PART NO.	OUTSIDE LENGTH (IN)	WEIGHT (LBS)
5V2240	224	2.46
5V2360	236	2.60
5V2500	250	2.75
5V2650	265	2.92
5V2800	280	3.08
5V3000	300	3.30
5V3150	315	3.47
5V3350	335	3.85
5V3550	355	3.91

SAMPLE PART # : 8V2800

## STANDARD V-BELTS

**8V** SECTION : 1"W x 7/8"H

PART NO.	OUTSIDE LENGTH (IN)	WEIGHT (LBS)
8V1000	100	3.20
8V1060	106	3.39
8V1120	112	3.58
8V1180	118	3.78
8V1250	125	4.00
8V1320	132	4.22
8V1400	140	4.48
8V1500	150	4.80

PART NO.	OUTSIDE LENGTH (IN)	WEIGHT (LBS)
8V1600	160	5.12
8V1700	170	5.44
8V1800	180	5.76
8V1900	190	6.08
8V2000	200	6.40
8V2120	212	6.78
8V2240	224	7.17
8V2360	236	7.55

PART NO.	OUTSIDE LENGTH (IN)	WEIGHT (LBS)
8V2500	250	8.00
8V2650	265	8.48
8V2800	280	8.96
8V3000	300	9.60
8V3150	315	10.08
8V3350	335	10.72
8V3550	355	11.36
8V3750	375	12.00

PART NO.	OUTSIDE LENGTH (IN)	WEIGHT (LBS)
8V4000	400	12.80
8V4250	425	13.60
8V4500	450	14.40
8V5000	500	16.00
8V5600	560	17.92
8V6000	600	19.20

## HAVE ANY QUESTIONS? CONTACT CUSTOMER SERVICE

800-292-6081    INFO@OPTIBELT-USA.COM

### S=C Length Tolerances

Standard on all OPTIBELT single V-belts and Wedge belts 47" in length and above. S=C Plus V-belts are always superior to a matched-set regardless of the date manufactured. Not available on aramid cord, banded or cogged belts.

### Custom Sizes & Ordering

Section / Max. Mfg Lengths / Min. qty.

- 3V / 157 in. / 40
- 5V / 475 in. / 25
- 8V / 708 in. / 14

Contact customer service for details.

Contact an OPTIBELT representative regarding additional sizes, stock availability and pricing.

All weights are estimated.

Additional sizes and stocking available.



**SK**  
METRIC V-BELTS

**SPZ** SECTION : 9.7mm W x 8mm H

**METRIC V-BELTS**

SAMPLE PART # : SPZ1537

PART NO.	DATUM LENGTH (MM)	WEIGHT (LBS)
SPZ487	487	.08
SPZ512	512	.08
SPZ562	562	.09
SPZ587	587	.09
SPZ612	612	.10
SPZ630	630	.10
SPZ637	637	.10
SPZ662	662	.11
SPZ670	670	.11
SPZ687	687	.11
SPZ710	710	.12
SPZ722	722	.12
SPZ737	737	.12
SPZ750	750	.12
SPZ762	762	.12
SPZ772	772	.13
SPZ787	787	.13
SPZ800	800	.13
SPZ812	812	.13
SPZ825	825	.13
SPZ837	837	.14
SPZ850	850	.14
SPZ862	862	.14
SPZ875	875	.14
SPZ887	887	.15
SPZ900	900	.15

PART NO.	DATUM LENGTH (MM)	WEIGHT (LBS)
SPZ912	912	.15
SPZ925	925	.15
SPZ937	937	.15
SPZ950	950	.15
SPZ962	962	.16
SPZ987	987	.16
SPZ1000	1000	.16
SPZ1012	1012	.17
SPZ1024	1024	.17
SPZ1037	1037	.17
SPZ1047	1047	.17
SPZ1060	1060	.17
SPZ1077	1077	.18
SPZ1087	1087	.18
SPZ1112	1112	.18
SPZ1120	1120	.18
SPZ1137	1137	.18
SPZ1162	1162	.19
SPZ1180	1180	.19
SPZ1187	1187	.19
SPZ1202	1202	.20
SPZ1212	1212	.20
SPZ1237	1237	.20
SPZ1250	1250	.20
SPZ1262	1262	.20
SPZ1287	1287	.21

PART NO.	DATUM LENGTH (MM)	WEIGHT (LBS)
SPZ1312	1312	.21
SPZ1320	1320	.22
SPZ1337	1337	.22
SPZ1347	1347	.22
SPZ1362	1362	.22
SPZ1387	1387	.23
SPZ1400	1400	.23
SPZ1412	1412	.23
SPZ1437	1437	.23
SPZ1462	1462	.24
SPZ1487	1487	.24
SPZ1500	1500	.24
SPZ1512	1512	.25
SPZ1537	1537	.25
SPZ1562	1562	.26
SPZ1587	1587	.26
SPZ1600	1600	.26
SPZ1612	1612	.26
SPZ1637	1637	.27
SPZ1650	1650	.27
SPZ1662	1662	.27
SPZ1687	1687	.28
SPZ1700	1700	.28
SPZ1737	1737	.28
SPZ1762	1762	.29
SPZ1787	1787	.29

PART NO.	DATUM LENGTH (MM)	WEIGHT (LBS)
SPZ1800	1800	.29
SPZ1812	1812	.29
SPZ1837	1837	.30
SPZ1850	1850	.30
SPZ1862	1862	.30
SPZ1887	1887	.31
SPZ1900	1900	.31
SPZ1937	1937	.31
SPZ1987	1987	.32
SPZ2000	2000	.33
SPZ2037	2037	.33
SPZ2120	2120	.35
SPZ2137	2137	.35
SPZ2187	2187	.36
SPZ2240	2240	.37
SPZ2287	2287	.37
SPZ2360	2360	.39
SPZ2500	2500	.41
SPZ2650	2650	.43
SPZ2800	2800	.46
SPZ3000	3000	.49
SPZ3150	3150	.51
SPZ3350	3350	.55
SPZ3550	3550	.58

SPZ DATUM LENGTH +13mm = OUTSIDE LENGTH

**SPA** SECTION : 12.7mm W x 10mm H

**METRIC V-BELTS**

SAMPLE PART # : SPA1107

PART NO.	DATUM LENGTH (MM)	WEIGHT (LBS)
SPA707	707	.19
SPA732	732	.20
SPA757	757	.20
SPA782	782	.21
SPA800	800	.22
SPA807	807	.22
SPA832	832	.22
SPA850	850	.23

PART NO.	DATUM LENGTH (MM)	WEIGHT (LBS)
SPA857	857	.23
SPA882	882	.24
SPA900	900	.24
SPA907	907	.25
SPA932	932	.25
SPA950	950	.26
SPA957	957	.26
SPA982	982	.27

PART NO.	DATUM LENGTH (MM)	WEIGHT (LBS)
SPA1000	1000	.27
SPA1007	1007	.27
SPA1032	1032	.28
SPA1060	1060	.29
SPA1082	1082	.29
SPA1107	1107	.30
SPA1120	1120	.30
SPA1132	1132	.31

PART NO.	DATUM LENGTH (MM)	WEIGHT (LBS)
SPA1157	1157	.31
SPA1180	1180	.32
SPA1207	1207	.33
SPA1232	1232	.33
SPA1250	1250	.34
SPA1257	1257	.34

**SPA SECTIONS CONT. PG 25**

SPA DATUM LENGTH +18mm = OUTSIDE LENGTH

Contact an OPTIBELT representative regarding additional sizes, stock availability and pricing.

All weights are estimated.

Additional sizes and stocking available.

**Custom Sizes & Ordering**

Section / Max. Mfg Lengths / Min. qty.

- SPZ / 4,500 mm / 20
- SPA / 4,500 mm / 31

Contact customer service for details.

**S=C Length Tolerances**

Standard on all OPTIBELT single V-belts and Wedge belts 47" in length and above. S=C Plus V-belts are always superior to a matched-set regardless of the date manufactured. Not available on aramid cord, banded or cogged belts.



METRIC V-BELTS  
**SK**

SAMPLE PART # : SPA2607

### METRIC V-BELTS

SPA SECTION : 12.7mm W x 10mm H

PART NO.	DATUM LENGTH (MM)	WEIGHT (LBS)
SPA1272	1272	.34
SPA1282	1282	.35
SPA1307	1307	.35
SPA1320	1320	.36
SPA1332	1332	.36
SPA1357	1357	.37
SPA1382	1382	.37
SPA1400	1400	.38
SPA1407	1407	.38
SPA1432	1432	.39
SPA1457	1457	.39
SPA1482	1482	.40
SPA1500	1500	.41
SPA1507	1507	.41
SPA1532	1532	.41
SPA1557	1557	.42
SPA1582	1582	.43
SPA1600	1600	.43
SPA1607	1607	.44
SPA1632	1632	.44
SPA1657	1657	.45

PART NO.	DATUM LENGTH (MM)	WEIGHT (LBS)
SPA1682	1682	.46
SPA1700	1700	.46
SPA1707	1707	.46
SPA1732	1732	.47
SPA1757	1757	.48
SPA1782	1782	.48
SPA1800	1800	.49
SPA1807	1807	.49
SPA1832	1832	.50
SPA1857	1857	.50
SPA1882	1882	.51
SPA1900	1900	.51
SPA1907	1907	.52
SPA1932	1932	.52
SPA1957	1957	.53
SPA1982	1982	.54
SPA2000	2000	.54
SPA2032	2032	.55
SPA2057	2057	.56
SPA2082	2082	.56
SPA2120	2120	.57

PART NO.	DATUM LENGTH (MM)	WEIGHT (LBS)
SPA2132	2132	.58
SPA2182	2182	.59
SPA2207	2207	.60
SPA2232	2232	.61
SPA2240	2240	.61
SPA2282	2282	.62
SPA2300	2300	.62
SPA2307	2307	.62
SPA2332	2332	.63
SPA2360	2360	.64
SPA2382	2382	.64
SPA2432	2432	.66
SPA2482	2482	.67
SPA2500	2500	.68
SPA2532	2532	.68
SPA2582	2582	.70
SPA2607	2607	.71
SPA2632	2632	.71
SPA2650	2650	.72
SPA2682	2682	.73
SPA2732	2732	.74

PART NO.	DATUM LENGTH (MM)	WEIGHT (LBS)
SPA2782	2782	.75
SPA2800	2800	.76
SPA2832	2832	.77
SPA2847	2847	.77
SPA2882	2882	.78
SPA2932	2932	.79
SPA2982	2982	.81
SPA3000	3000	.81
SPA3032	3032	.82
SPA3082	3082	.83
SPA3150	3150	.85
SPA3182	3182	.86
SPA3282	3282	.89
SPA3350	3350	.91
SPA3382	3382	.92
SPA3550	3550	.96
SPA3750	3750	1.01
SPA4000	4000	1.08
SPA4250	4250	1.15
SPA4500	4500	1.22

SPA DATUM LENGTH +18mm = OUTSIDE LENGTH

SAMPLE PART # : SPB1600

### METRIC V-BELTS

SPB SECTION : 16.3mm W x 13mm H

PART NO.	DATUM LENGTH (MM)	WEIGHT (LBS)
SPB1250	1250	.54
SPB1320	1320	.57
SPB1400	1400	.60
SPB1450	1450	.62
SPB1500	1500	.64
SPB1600	1600	.69
SPB1700	1700	.73
SPB1750	1750	.75
SPB1800	1800	.77
SPB1850	1850	.79
SPB1900	1900	.82

PART NO.	DATUM LENGTH (MM)	WEIGHT (LBS)
SPB2000	2000	.86
SPB2020	2020	.87
SPB2060	2060	.88
SPB2120	2120	.91
SPB2180	2180	.94
SPB2240	2240	.96
SPB2360	2360	1.01
SPB2500	2500	1.07
SPB2650	2650	1.14
SPB2800	2800	1.20
SPB2850	2850	1.22

PART NO.	DATUM LENGTH (MM)	WEIGHT (LBS)
SPB2900	2900	1.25
SPB3000	3000	1.29
SPB3150	3150	1.35
SPB3250	3250	1.39
SPB3350	3350	1.44
SPB3450	3450	1.48
SPB3550	3550	1.52
SPB3650	3650	1.57
SPB3750	3750	1.61
SPB4000	4000	1.72
SPB4250	4250	1.82

PART NO.	DATUM LENGTH (MM)	WEIGHT (LBS)
SPB4500	4500	1.93
SPB4750	4750	2.04
SPB5000	5000	2.15
SPB5300	5300	2.27
SPB5600	5600	2.40
SPB6000	6000	2.57
SPB6300	6300	2.70
SPB6700	6700	2.88
SPB7100	7100	3.05
SPB7500	7500	3.22
SPB8000	8000	3.43

SPB DATUM LENGTH +22mm = OUTSIDE LENGTH



#### S=C Length Tolerances

Standard on all OPTIBELT single V-belts and Wedge belts 47" in length and above. S=C Plus V-belts are always superior to a matched-set regardless of the date manufactured. Not available on aramid cord, banded or cogged belts.

#### Sizes & Ordering

Section / Max. Mfg Lengths / Min. qty.

- SPA / 4,500 mm / 31
- SPB / 18,000 mm / 25

Contact customer service for details.

Contact an OPTIBELT representative regarding additional sizes, stock availability and pricing.

All weights are estimated.

Additional sizes and stocking available.



**SK**  
METRIC V-BELTS

SAMPLE PART # : SPC4750

**METRIC V-BELTS**

**SPC** SECTION : 22mm W x 18mm H

PART NO.	DATUM LENGTH (MM)	WEIGHT (LBS)
SPC2000	2000	1.66
SPC2120	2120	1.76
SPC2240	2240	1.86
SPC2360	2360	1.96
SPC2500	2500	2.07
SPC2650	2650	2.20
SPC2800	2800	2.32
SPC3000	3000	2.49

PART NO.	DATUM LENGTH (MM)	WEIGHT (LBS)
SPC3150	3150	2.61
SPC3350	3350	2.78
SPC3550	3550	2.94
SPC3750	3750	3.11
SPC4000	4000	3.32
SPC4250	4250	3.52
SPC4500	4500	3.73
SPC4750	4750	3.94

PART NO.	DATUM LENGTH (MM)	WEIGHT (LBS)
SPC5000	5000	4.15
SPC5300	5300	4.40
SPC5600	5600	4.64
SPC6000	6000	4.98
SPC6300	6300	5.23
SPC6700	6700	5.56
SPC7100	7100	5.89
SPC7500	7500	6.22

PART NO.	DATUM LENGTH (MM)	WEIGHT (LBS)
SPC8000	8000	6.64
SPC8500	8500	7.05
SPC9000	9000	7.46
SPC9500	9500	7.88
SPC10000	10000	8.29
SPC10600	10600	8.79
SPC11200	11200	9.29
SPC12500	12500	10.37

SPC DATUM LENGTH +30mm = OUTSIDE LENGTH

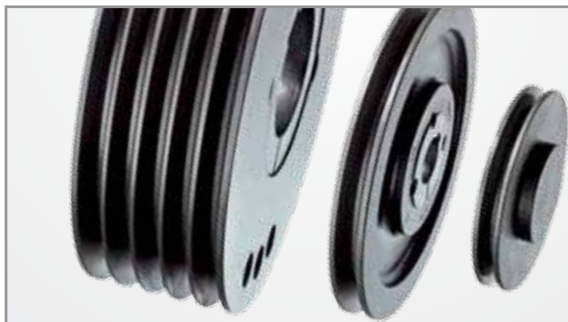

**NEED METRIC SHEAVES?**

**124**

**KS SHEAVES, METRIC**

- **124-125**    **SECTIONS: SPZ/10**
- **126-127**    **SECTIONS: SPA/13**
- **128-130**    **SECTIONS: SPB/17**
- **131-132**    **SECTIONS: SPC/22**

Contact an OPTIBELT representative regarding additional sizes, stock availability and pricing.

All weights are estimated.

Additional sizes and stocking available upon request

**Sizes & Ordering**

Section / Max. Mfg Lengths / Min. qty.

- SPC / 21,000 mm / 16

Contact customer service for details.

**S=C Length Tolerances**

Standard on all OPTIBELT single V-belts and Wedge belts 47" in length and above. S=C Plus V-belts are always superior to a matched-set regardless of the date manufactured. Not available on aramid cord, banded or cogged belts.



**3L** SECTION : 3/8"W x 5/16"H

**CLASSIC V-BELTS**

SAMPLE PART # : 3L450

PART NO.	OUTSIDE LENGTH (IN)	WEIGHT (LBS)
3L130	13	.04
3L160	16	.05
3L170	17	.06
3L180	18	.06
3L190	19	.06
3L200	20	.06
3L210	21	.07
3L220	22	.07
3L230	23	.07
3L240	24	.08
3L250	25	.08
3L260	26	.08
3L270	27	.09
3L280	28	.09

PART NO.	OUTSIDE LENGTH (IN)	WEIGHT (LBS)
3L290	29	.09
3L300	30	.10
3L310	31	.10
3L320	32	.10
3L330	33	.11
3L340	34	.11
3L350	35	.11
3L360	36	.12
3L370	37	.12
3L380	38	.12
3L390	39	.13
3L400	40	.13
3L410	41	.13

PART NO.	OUTSIDE LENGTH (IN)	WEIGHT (LBS)
3L420	42	.14
3L430	43	.14
3L440	44	.14
3L450	45	.15
3L460	46	.15
3L470	47	.15
3L480	48	.16
3L490	49	.16
3L500	50	.16
3L510	51	.17
3L520	52	.17
3L530	53	.17
3L540	54	.18

PART NO.	OUTSIDE LENGTH (IN)	WEIGHT (LBS)
3L550	55	.18
3L560	56	.18
3L570	57	.18
3L580	58	.19
3L590	59	.19
3L600	60	.19
3L610	61	.20
3L620	62	.22
3L630	63	.22
3L640	64	.23
3L650	65	.23
3L660	66	.24
3L740	74	.26

**4L** SECTION : 1/2"W x 11/32"H

**CLASSIC V-BELTS**

SAMPLE PART # : 4L180

**A** SECTION : 1/2"W x 11/32"H

ALTERNATE REFERENCE SIZE

PART NO.	ALT. REF. SIZE	OUTSIDE LENGTH (IN)	WEIGHT (LBS)
4L160	A14	16	.09
4L170	A15	17	.10
4L180	A16	18	.11
4L190	A17	19	.11
4L200	A18	20	.12
4L210	A19	21	.12
4L220	A20	22	.13
4L230	A21	23	.14
4L240	A22	24	.14
4L250	A23	25	.15
4L255	A23.5	25.5	.15
4L260	A24	26	.15
4L270	A25	27	.16
4L275	A25.5	27.5	.16
4L280	A26	28	.17
4L290	A27	29	.17
4L300	A28	30	.18
4L310	A29	31	.18
4L320	A30	32	.19

PART NO.	ALT. REF. SIZE	OUTSIDE LENGTH (IN)	WEIGHT (LBS)
4L330	A31	33	.20
4L340	A32	34	.20
4L350	A33	35	.21
4L360	A34	36	.21
4L370	A35	37	.22
4L380	A36	38	.22
4L390	A37	39	.23
4L400	A38	40	.24
4L410	A39	41	.24
4L420	A40	42	.25
4L430	A41	43	.26
4L440	A42	44	.26
4L450	A43	45	.27
4L460	A44	46	.27
4L470	A45	47	.28
4L480	A46	48	.28
4L490	A47	49	.29
4L500	A48	50	.30
4L510	A49	51	.30

PART NO.	ALT. REF. SIZE	OUTSIDE LENGTH (IN)	WEIGHT (LBS)
4L520	A50	52	.31
4L530	A51	53	.31
4L540	A52	54	.32
4L550	A53	55	.33
4L560	A54	56	.33
4L570	A55	57	.34
4L580	A56	58	.34
4L590	A57	59	.35
4L600	A58	60	.36
4L610	A59	61	.36
4L620	A60	62	.37
4L630	A61	63	.37
4L640	A62	64	.38
4L650	A63	65	.39
4L660	A64	66	.39
4L670	A65	67	.40
4L680	A66	68	.40

**4L SECTIONS CONTINUED PG 28**

**SAVE HUNDREDS A YEAR!**

OPTIBELT'S HVAC Power is a fractional horsepower belt with heavy-duty performance and durability. See page pg 12 for details.

**Sizes & Ordering**

Additional and custom sizes available. Contact customer service for details.

Contact an OPTIBELT representative regarding additional sizes, stock availability and pricing.

All weights are estimated.

Additional sizes and stocking available.



LD  
V-BELTS

SAMPLE PART # : 4L780

**CLASSIC V-BELTS**

**4L** SECTION : 1/2"W x 11/32"H

ALTERNATE REFERENCE SIZE

**A** SECTION : 1/2"W x 11/32"H

PART NO.	ALT. REF. SIZE	OUTSIDE LENGTH (IN)	WEIGHT (LBS)
4L690	A67	69	.41
4L700	A68	70	.41
4L710	A69	71	.43
4L720	A70	72	.43
4L730	A71	73	.44
4L740	A72	74	.45

PART NO.	ALT. REF. SIZE	OUTSIDE LENGTH (IN)	WEIGHT (LBS)
4L750	A73	75	.45
4L760	A74	76	.46
4L770	A75	77	.46
4L780	A76	78	.47
4L790	A77	79	.48
4L800	A78	80	.48

PART NO.	ALT. REF. SIZE	OUTSIDE LENGTH (IN)	WEIGHT (LBS)
4L810	A79	81	.49
4L820	A80	82	.50
4L880	A86	88	.53
4L900	A88	90	.54
4L970	A95	97	.59

SAMPLE PART # : B50

**CLASSIC V-BELTS**

**5L** SECTION : 21/32"W x 7/16"H

ALTERNATE REFERENCE SIZE

**B** SECTION : 21/32"W x 7/16"H

PART NO.	ALT. REF. SIZE	OUTSIDE LENGTH (IN)	WEIGHT (LBS)
5L230	B20	23	.21
5L240	B21	24	.22
5L250	B22	25	.23
5L260	B23	26	.24
5L270	B24	27	.25
5L280	B25	28	.26
5L290	B26	29	.27
5L300	B27	30	.28
5L310	B28	31	.29
5L320	B29	32	.29
5L330	B30	33	.30
5L340	B31	34	.31
5L350	B32	35	.32
5L360	B33	36	.33
5L370	B34	37	.34
5L380	B35	38	.35
5L390	B36	39	.36
5L400	B37	40	.37
5L410	B38	41	.38
5L420	B39	42	.39
5L430	B40	43	.40
5L440	B41	44	.40

PART NO.	ALT. REF. SIZE	OUTSIDE LENGTH (IN)	WEIGHT (LBS)
5L450	B42	45	.42
5L460	B43	46	.42
5L470	B44	47	.43
5L480	B45	48	.44
5L490	B46	49	.45
5L500	B47	50	.46
5L510	B48	51	.47
5L520	B49	52	.48
5L530	B50	53	.49
5L540	B51	54	.50
5L550	B52	55	.51
5L560	B53	56	.52
5L570	B54	57	.53
5L580	B55	58	.53
5L590	B56	59	.54
5L600	B57	60	.55
5L610	B58	61	.56
5L620	B59	62	.57
5L630	B60	63	.58
5L640	B61	64	.59
5L650	B62	65	.60
5L660	B63	66	.61

PART NO.	ALT. REF. SIZE	OUTSIDE LENGTH (IN)	WEIGHT (LBS)
5L670	B64	67	.62
5L680	B65	68	.63
5L690	B66	69	.64
5L700	B67	70	.64
5L710	B68	71	1.23
5L720	B69	72	1.23
5L730	B70	73	1.28
5L740	B71	74	1.28
5L750	B72	75	1.30
5L760	B73	76	1.30
5L770	B74	77	1.34
5L780	B75	78	1.34
5L790	B76	79	1.36
5L810	B78	81	1.39
5L820	B79	82	1.41
5L830	B80	83	1.42
5L840	B81	84	1.43
5L850	B82	85	1.45
5L860	B83	86	1.45
5L880	B85	88	1.50
5L900	B87	90	1.54

Because of the demands placed on larger 5L profile belts the B section part number is listed as the part number. Contact a customer service representative for more information.

**SAVE HUNDREDS A YEAR!**

HVAC POWER is a fractional horsepower belt with heavy-duty performance and durability. See page pg 12 for details.

Contact an OPTIBELT representative regarding additional sizes, stock availability and pricing.

All weights are estimated.

Additional sizes and stocking available upon request

**Sizes & Ordering**

Additional and custom sizes available. Contact customer service for details.

**Need Help?**

Contact OPTIBELT customer service. Our friendly staff is here to assist you. TOLL FREE: 800-292-6081 E-MAIL: info@optibelt-usa.com

# 3VX & 5VX SECTIONS

MATCHED-SET TOLERANCES

# optibelt SUPER X-POWER

COGGED, SINGLE



SUPER X-POWER is the high performance solution for cogged belt applications. It is constructed using OPTIBELT'S superior transverse fiber core compound, low stretch polyester cord, and cord stabilizing cushion compound. Available in single or banded sizes.

- **High Performance:** Improves performance 15% over standard raw edged cogged belts.
- **Greater Efficiency:** Low-stretch cords resist stretching for improved efficiency and less maintenance.
- **Temperature Range:** Increased ranges from -22 to 194°F
- **Matched-Sets (M=5):** Meet industry tolerances for matched-sets without the need for remeasuring or matching date codes.



SUPER X-POWER  
STANDARD COGGED

SAMPLE PART # : 3VX670

## STANDARD COGGED

3VX SECTION : 3/8"W x 5/16"H

PART NO.	OUTSIDE LENGTH (IN)	WEIGHT (LBS)
3VX250	25	.09
3VX265	26.5	.10
3VX280	28	.10
3VX300	30	.11
3VX315	31.5	.11
3VX335	33.5	.12
3VX355	35.5	.13
3VX375	37.5	.14

PART NO.	OUTSIDE LENGTH (IN)	WEIGHT (LBS)
3VX400	40	.14
3VX425	42.5	.15
3VX450	45	.16
3VX475	47.5	.17
3VX500	50	.18
3VX530	53	.19
3VX560	56	.20
3VX600	60	.22

PART NO.	OUTSIDE LENGTH (IN)	WEIGHT (LBS)
3VX630	63	.23
3VX670	67	.24
3VX710	71	.26
3VX750	75	.27
3VX800	80	.29
3VX850	85	.31
3VX900	90	.32
3VX950	95	.34

PART NO.	OUTSIDE LENGTH (IN)	WEIGHT (LBS)
3VX 1000	100	.36
3VX 1060	106	.38
3VX 1120	112	.40
3VX 1180	118	.42
3VX 1250	125	.45
3VX 1320	132	.48
3VX 1400	140	.50

SAMPLE PART # : 5VX 930

## STANDARD COGGED

5VX SECTION : 5/8"W x 17/32"H

PART NO.	OUTSIDE LENGTH (IN)	WEIGHT (LBS)
• 5VX450	45	.45
• 5VX470	47	.47
• 5VX490	49	.49
5VX500	50	.50
• 5VX510	51	.51
5VX530	53	.53
• 5VX540	54	.54
• 5VX550	55	.55
5VX560	56	.56
• 5VX570	57	.57
• 5VX580	58	.58
• 5VX590	59	.59
5VX600	60	.60

PART NO.	OUTSIDE LENGTH (IN)	WEIGHT (LBS)
• 5VX610	61	.61
5VX630	63	.63
• 5VX650	65	.65
• 5VX660	66	.66
5VX670	67	.67
• 5VX680	68	.68
• 5VX690	69	.69
5VX710	71	.71
• 5VX730	73	.73
• 5VX740	74	.74
5VX750	75	.75
• 5VX780	78	.78
• 5VX800	80	.80

PART NO.	OUTSIDE LENGTH (IN)	WEIGHT (LBS)
• 5VX830	83	.83
• 5VX840	84	.84
5VX850	85	.85
• 5VX860	86	.86
• 5VX880	88	.88
5VX900	90	.90
• 5VX930	93	.93
5VX950	95	.95
• 5VX960	96	.96
5VX1000	100	1.00
5VX1030	103	1.03
5VX1060	106	1.06
5VX1080	108	1.08

PART NO.	OUTSIDE LENGTH (IN)	WEIGHT (LBS)
5VX1120	112	1.12
5VX1180	118	1.18
• 5VX1230	123	1.23
5VX1250	125	1.25
5VX1320	132	1.32
5VX1400	140	1.40
• 5VX1500	150	1.50
• 5VX1600	160	1.60
• 5VX1700	170	1.70
• 5VX1800	180	1.80
• 5VX1900	190	1.90
• 5VX2000	200	2.00

### M=S Length Tolerances

Matched Set (M=S) Belts all meet industry tolerances for matched-sets without the need for remeasuring or matching date codes.

### Custom Sizes & Ordering

Additional stocked and custom sizes available. Contact customer service for details.

### • INDICATES SUPER TX CONSTRUCTION

Contact an OPTIBELT representative regarding additional sizes, stock availability and pricing.

All weights are estimated.

Additional sizes and stocking available.



**XPZ** SECTION : 9.7mm x 8mm

**METRIC COGGED**

SAMPLE PART # : XPZ887

PART NO.	DATUM LENGTH (MM)	WEIGHT (LBS)
XPZ587	587	.09
XPZ612	612	.09
XPZ630	630	.09
XPZ637	637	.10
XPZ662	662	.10
XPZ670	670	.10
XPZ687	687	.10
XPZ710	710	.11
XPZ730	730	.11
XPZ737	737	.11
XPZ750	750	.11
XPZ762	762	.12
XPZ772	772	.12
XPZ787	787	.12
XPZ800	800	.12
XPZ812	812	.12
XPZ825	825	.13
XPZ837	837	.13
XPZ850	850	.13
XPZ862	862	.13
XPZ875	875	.13
XPZ887	887	.13

PART NO.	OUTSIDE LENGTH (MM)	WEIGHT (LBS)
XPZ900	900	.14
XPZ912	912	.14
XPZ925	925	.14
XPZ937	937	.14
XPZ950	950	.15
XPZ962	962	.15
XPZ987	987	.15
XPZ1000	1000	.15
XPZ1012	1012	.15
XPZ1037	1037	.16
XPZ1060	1060	.16
XPZ1077	1077	.16
XPZ1087	1087	.17
XPZ1112	1112	.17
XPZ1120	1120	.17
XPZ1137	1137	.17
XPZ1162	1162	.18
XPZ1180	1180	.18
XPZ1187	1187	.18
XPZ1202	1202	.18
XPZ1212	1212	.18
XPZ1237	1237	.19

PART NO.	OUTSIDE LENGTH (MM)	WEIGHT (LBS)
XPZ1250	1250	.19
XPZ1262	1262	.19
XPZ1287	1287	.20
XPZ1312	1312	.20
XPZ1320	1320	.20
XPZ1337	1337	.20
XPZ1362	1362	.21
XPZ1387	1387	.21
XPZ1400	1400	.21
XPZ1412	1412	.21
XPZ1437	1437	.22
XPZ1462	1462	.22
XPZ1487	1487	.23
XPZ1500	1500	.23
XPZ1512	1512	.23
XPZ1537	1537	.23
XPZ1562	1562	.24
XPZ1587	1587	.24
XPZ1600	1600	.24
XPZ1612	1612	.24
XPZ1662	1662	.25
XPZ1700	1700	.26

PART NO.	OUTSIDE LENGTH (MM)	WEIGHT (LBS)
XPZ1750	1750	.27
XPZ1762	1762	.27
XPZ1800	1800	.27
XPZ1850	1850	.28
XPZ1900	1900	.29
XPZ1950	1950	.30
XPZ2000	2000	.30
XPZ2120	2120	.32
XPZ2150	2150	.33
XPZ2240	2240	.34
XPZ2360	2360	.36
XPZ2500	2500	.38
XPZ2540	2540	.39
XPZ2650	2650	.40
XPZ2690	2690	.41
XPZ2800	2800	.42
XPZ2840	2840	.43
XPZ3000	3000	.46
XPZ3150	3150	.48
XPZ3350	3350	.51
XPZ3550	3550	.54

XPZ DATUM LENGTH +13mm = OUTSIDE LENGTH

**XPA** SECTION : 12.7mm x 10mm

**METRIC COGGED**

SAMPLE PART # : XPZ887

PART NO.	DATUM LENGTH (MM)	WEIGHT (LBS)
XPA707	707	.17
XPA732	732	.17
XPA757	757	.18
XPA782	782	.18
XPA800	800	.19
XPA807	807	.19
XPA832	832	.19
XPA850	850	.20
XPA857	857	.20
XPA882	882	.20
XPA900	900	.21
XPA907	907	.21

PART NO.	DATUM LENGTH (MM)	WEIGHT (LBS)
XPA932	932	.22
XPA950	950	.22
XPA957	957	.22
XPA982	982	.23
XPA1000	1000	.23
XPA1007	1007	.24
XPA1030	1030	.24
XPA1060	1060	.25
XPA1082	1082	.25
XPA1107	1107	.26
XPA1120	1120	.26
XPA1132	1132	.26

PART NO.	DATUM LENGTH (MM)	WEIGHT (LBS)
XPA1157	1157	.27
XPA1180	1180	.28
XPA1207	1207	.28
XPA1232	1232	.29
XPA1250	1250	.29
XPA1257	1257	.29
XPA1272	1272	.30
XPA1282	1282	.30
XPA1307	1307	.31
XPA1320	1320	.31
XPA1332	1332	.31
XPA1357	1357	.32

PART NO.	DATUM LENGTH (MM)	WEIGHT (LBS)
XPA1382	1382	.32
XPA1400	1400	.33
XPA1432	1432	.33
XPA1450	1450	.34
XPA1457	1457	.34
XPA1482	1482	.35
XPA1500	1500	.35
XPA1507	1507	.35
XPA1532	1532	.36
XPA1557	1557	.36

**XPA SECTIONS CONTINUED PG 31**

XPA DATUM LENGTH +18mm = OUTSIDE LENGTH

Contact an OPTIBELT representative regarding additional sizes, stock availability and pricing.

All weights are estimated.

Additional sizes and stocking available upon request.

**Sizes & Ordering**

Additional stocked and custom sizes available. Contact customer service for details.

**M=S Length Tolerances**

Matched Set (M=S) Belts all meet industry tolerances for matched-sets without the need for remeasuring or matching date codes.





SUPER X-POWER  
METRIC COGGED

SAMPLE PART # : XPA1782

## METRIC COGGED

**XPA** SECTION : 12.7mm x 10mm

PART NO.	DATUM LENGTH (MM)	WEIGHT (LBS)
XPA1582	1582	.37
XPA1600	1600	.37
XPA1607	1607	.37
XPA1632	1632	.38
XPA1650	1650	.39
XPA1682	1682	.39
XPA1700	1700	.40
XPA1732	1732	.40

PART NO.	DATUM LENGTH (MM)	WEIGHT (LBS)
XPA1750	1750	.41
XPA1757	1757	.41
XPA1782	1782	.42
XPA1800	1800	.42
XPA1832	1832	.43
XPA1850	1850	.43
XPA1882	1882	.44
XPA1900	1900	.44

PART NO.	DATUM LENGTH (MM)	WEIGHT (LBS)
XPA1932	1932	.45
XPA1950	1950	.46
XPA1982	1982	.46
XPA2000	2000	.47
XPA2120	2120	.50
XPA2240	2240	.52
XPA2360	2360	.55

PART NO.	DATUM LENGTH (MM)	WEIGHT (LBS)
XPA2500	2500	.58
XPA2650	2650	.62
XPA2800	2800	.65
XPA3000	3000	.70
XPA3150	3150	.73
XPA3350	3350	.78
XPA3550	3550	.83

XPA DATUM LENGTH +18mm = OUTSIDE LENGTH

SAMPLE PART # : XPB1800

## METRIC COGGED

**XPB** SECTION : 16.3mm x 13mm

PART NO.	DATUM LENGTH (MM)	WEIGHT (LBS)
XPB1250	1250	.54
XPB1320	1320	.57
XPB1400	1400	.60
XPB1500	1500	.64
XPB1600	1600	.69
XPB1700	1700	.73
XPB1750	1750	.75

PART NO.	DATUM LENGTH (MM)	WEIGHT (LBS)
XPB1800	1800	.77
XPB1850	1850	.79
XPB1900	1900	.82
XPB2000	2000	.86
XPB2020	2020	.87
XPB2120	2120	.91
XPB2150	2150	.92

PART NO.	DATUM LENGTH (MM)	WEIGHT (LBS)
XPB2240	2240	.96
XPB2280	2280	.98
XPB2360	2360	1.01
XPB2400	2400	1.03
XPB2500	2500	1.07
XPB2650	2650	1.14
XPB2680	2680	1.15

PART NO.	DATUM LENGTH (MM)	WEIGHT (LBS)
XPB2800	2800	1.20
XPB2840	2840	1.22
XPB3000	3000	1.29
XPB3150	3150	1.35
XPB3350	3350	1.44
XPB3550	3550	1.52

XPB DATUM LENGTH +22mm = OUTSIDE LENGTH

SAMPLE PART # : XPC2650

## METRIC COGGED

**XPC** SECTION : 22mm x 18mm

PART NO.	DATUM LENGTH (MM)	WEIGHT (LBS)
XPC2000	2000	1.51
XPC2120	2120	1.60
XPC2240	2240	1.69

PART NO.	DATUM LENGTH (MM)	WEIGHT (LBS)
XPC2360	2360	1.78
XPC2500	2500	1.89
XPC2650	2650	2.00

PART NO.	DATUM LENGTH (MM)	WEIGHT (LBS)
XPC2800	2800	2.11
XPC3000	3000	2.26
XPC3150	3150	2.38

PART NO.	DATUM LENGTH (MM)	WEIGHT (LBS)
XPC3350	3350	2.53
XPC3550	3550	2.68

XPC DATUM LENGTH +30mm = OUTSIDE LENGTH

### M=S Length Tolerances

Matched Set (M=S) Belts all meet industry tolerances for matched-sets without the need for remeasuring or matching date codes.

### Custom Sizes & Ordering

Minimum production quantity applies. Contact customer service for maximum manufacturing lengths and details.

Contact an OPTIBELT representative regarding additional sizes, stock availability and pricing.

All weights are estimated.

Additional sizes and stocking available upon request.



**SUPER TX**  
CLASSIC COGGED

**AX** SECTION : 1/2"W x 11/32"H

**CLASSIC COGGED**

SAMPLE PART # : AX42

PART NO.	OUTSIDE LENGTH (IN)	WEIGHT (LBS)
AX20	22	.13
AX21	23	.14
AX22	24	.14
AX23	25	.15
AX24	26	.16
AX25	27	.16
AX26	28	.17
AX27	29	.17
AX28	30	.18
AX29	31	.19
AX30	32	.19
AX31	33	.20
AX32	34	.20
AX33	35	.21
AX34	36	.22
AX35	37	.22
AX36	38	.23

PART NO.	OUTSIDE LENGTH (IN)	WEIGHT (LBS)
AX37	39	.23
AX38	40	.24
AX39	41	.25
AX40	42	.25
AX41	43	.26
AX42	44	.26
AX43	45	.27
AX45	47	.28
AX46	48	.29
AX48	50	.30
AX49	51	.31
AX50	52	.31
AX51	53	.32
AX53	55	.33
AX54	56	.34
AX55	57	.34

PART NO.	OUTSIDE LENGTH (IN)	WEIGHT (LBS)
AX56	58	.35
AX58	60	.36
AX60	62	.37
AX62	64	.38
AX64	66	.40
AX65	67	.40
AX66	68	.41
AX68	70	.42
AX69	71	.426
AX70	72	.43
AX71	73	.44
AX75	77	.46
AX76	78	.47
AX78	80	.48
AX80	82	.49
AX82	84	.50

PART NO.	OUTSIDE LENGTH (IN)	WEIGHT (LBS)
AX83	85	.51
AX85	87	.52
AX88	90	.54
AX90	92	.55
AX92	94	.56
AX96	98	.59
AX97	99	.59
AX98	100	.60
AX100	102	.61
AX103	105	.63
AX105	107	.64
AX110	112	.67
AX112	114	.68
AX120	122	.73
AX128	130	.78
AX136	138	.83

**BX** SECTION : 21/32"W x 7/16"H

**CLASSIC COGGED**

SAMPLE PART # : BX115

PART NO.	OUTSIDE LENGTH (IN)	WEIGHT (LBS)
BX22	25	.28
BX28	31	.34
BX32	35	.39
BX34	37	.41
BX35	38	.42
BX36	39	.43
BX38	41	.45
BX40	43	.47
BX41	44	.48
BX42	45	.5
BX43	46	.51
BX44	47	.52
BX45	48	.53
BX46	49	.54
BX47	50	.55
BX48	51	.56
BX50	53	.58

PART NO.	OUTSIDE LENGTH (IN)	WEIGHT (LBS)
BX51	54	.59
BX52	55	.61
BX53	56	.62
BX54	57	.63
BX55	58	.64
BX56	59	.65
BX57	60	.66
BX58	61	.67
BX59	62	.68
BX60	63	.69
BX61	64	.70
BX62	65	.72
BX63	66	.73
BX64	67	.74
BX65	68	.75
BX66	69	.76
BX67	70	.77

PART NO.	OUTSIDE LENGTH (IN)	WEIGHT (LBS)
BX68	71	.78
BX70	73	.80
BX71	74	.81
BX72	75	.83
BX73	76	.84
BX74	77	.85
BX75	78	.86
BX76	79	.87
BX77	80	.88
BX78	81	.89
BX79	82	.90
BX80	83	.91
BX81	84	.92
BX82	85	.94
BX83	86	.95
BX85	88	.97
BX88	91	1.00

PART NO.	OUTSIDE LENGTH (IN)	WEIGHT (LBS)
BX90	93	1.02
BX93	96	1.06
BX95	98	1.08
BX96	99	1.09
BX97	100	1.10
BX99	102	1.12
BX100	103	1.13
BX103	106	1.17
BX105	108	1.19
BX108	111	1.22
BX112	115	1.27
BX113	116	1.28
BX115	118	1.30
BX116	119	1.31
BX118	121	1.33

**BX SECTIONS CONTINUED PG 33**

Contact an OPTIBELT representative regarding additional sizes, stock availability and pricing.

All weights are estimated.

Additional sizes and stocking available upon request.

**Custom Sizes & Ordering**

Minimum production quantity applies. Contact customer service for maximum manufacturing lengths and details.

**M=S Length Tolerances**

Matched Set (M=S) Belts all meet industry tolerances for matched-sets without the need for remeasuring or matching date codes.



SAMPLE PART # : BX180

**CLASSIC COGGED**

**BX** SECTION : 21/32"W x 7/16"H

PART NO.	OUTSIDE LENGTH (IN)	WEIGHT (LBS)
BX120	123	1.35
BX124	127	1.40
BX128	131	1.44
BX133	136	1.50

PART NO.	OUTSIDE LENGTH (IN)	WEIGHT (LBS)
BX136	139	1.53
BX144	147	1.62
BX150	153	1.68
BX158	161	1.77

PART NO.	OUTSIDE LENGTH (IN)	WEIGHT (LBS)
BX162	165	1.82
BX173	176	1.94
BX180	183	2.01
BX195	198	2.18

PART NO.	OUTSIDE LENGTH (IN)	WEIGHT (LBS)
BX210	213	2.34
BX270	273	3.00
BX300	303	3.33

SAMPLE PART # : CX136

**CLASSIC COGGED**

**CX** SECTION : 7/8"W x 9/16"H

PART NO.	OUTSIDE LENGTH (IN)	WEIGHT (LBS)
CX51	55	.99
CX60	64	1.15
CX67	71	1.28
CX68	72	1.30
CX75	79	1.42
CX81	85	1.53
CX85	89	1.60
CX90	94	1.69

PART NO.	OUTSIDE LENGTH (IN)	WEIGHT (LBS)
CX96	100	1.80
CX105	109	1.96
CX109	113	2.03
CX112	116	2.09
CX115	119	2.14
CX120	124	2.23
CX128	132	2.38
CX136	140	2.52

PART NO.	OUTSIDE LENGTH (IN)	WEIGHT (LBS)
CX144	148	2.66
CX147	151	2.72
CX148	152	2.74
CX158	162	2.92
CX162	166	2.99
CX173	177	3.19
CX180	184	3.31

PART NO.	OUTSIDE LENGTH (IN)	WEIGHT (LBS)
CX195	199	3.58
CX210	214	3.85
CX225	229	4.09
CX240	244	4.36
CX255	259	4.63
CX270	274	4.90
CX300	304	5.44

<p><b>M=S Length Tolerances</b> Matched Set (M=S) Belts all meet industry tolerances for matched-sets without the need for remeasuring or matching date codes.</p>	<p><b>Custom Sizes &amp; Ordering</b> Additional stocked and custom sizes available. Contact customer service for details.</p>	<p>Contact an OPTIBELT representative regarding additional sizes, stock availability and pricing.  All weights are estimated.  Additional sizes and stocking available.</p>
------------------------------------------------------------------------------------------------------------------------------------------------------------------------	----------------------------------------------------------------------------------------------------------------------------------------	---------------------------------------------------------------------------------------------------------------------------------------------------------------------------------------------



**5V SECTION : 5/8"W x 5/8"H**

**STANDARD BANDED**

SAMPLE PART # : 4/5VBP900

PART NO.	OUTSIDE LENGTH (IN)	WEIGHT (LBS) (PER RIB)
5VBP800	80	1.13
5VBP850	85	1.20
5VBP900	90	1.28
5VBP950	95	1.35
5VBP1000	100	1.42
5VBP1060	106	1.50
5VBP1120	112	1.59

PART NO.	OUTSIDE LENGTH (IN)	WEIGHT (LBS) (PER RIB)
5VBP1180	118	1.67
5VBP1250	125	1.77
5VBP1320	132	1.87
5VBP1400	140	1.98
5VBP1500	150	2.12
5VBP1600	160	2.26
5VBP1700	170	2.41

PART NO.	OUTSIDE LENGTH (IN)	WEIGHT (LBS) (PER RIB)
5VBP1800	180	2.55
5VBP1900	190	2.69
5VBP2000	200	2.83
5VBP2120	212	3.00
5VBP2240	224	3.17
5VBP2360	236	3.34
5VBP2500	250	3.54

PART NO.	OUTSIDE LENGTH (IN)	WEIGHT (LBS) (PER RIB)
5VBP2650	265	3.75
5VBP2800	280	3.96
5VBP3000	300	4.24
5VBP3150	315	4.46

**8V SECTION : 1"W x 1-1/64"H**

**STANDARD BANDED**

SAMPLE PART # : 6/8VBP2800

PART NO.	OUTSIDE LENGTH (IN)	WEIGHT (LBS) (PER RIB)
8VBP1000	100	4.13
8VBP1060	106	4.37
8VBP1120	112	4.62
8VBP1180	118	4.87
8VBP1250	125	5.16
8VBP1320	132	5.45
8VBP1400	140	5.78

PART NO.	OUTSIDE LENGTH (IN)	WEIGHT (LBS) (PER RIB)
8VBP1500	150	6.19
8VBP1600	160	6.60
8VBP1700	170	7.01
8VBP1800	180	7.43
8VBP1900	190	7.84
8VBP2000	200	8.25
8VBP2120	212	8.74

PART NO.	OUTSIDE LENGTH (IN)	WEIGHT (LBS) (PER RIB)
8VBP2240	224	9.24
8VBP2360	236	9.73
8VBP2500	250	10.31
8VBP2650	265	10.93
8VBP2800	280	11.55
8VBP3000	300	12.37
8VBP3150	315	12.99

PART NO.	OUTSIDE LENGTH (IN)	WEIGHT (LBS) (PER RIB)
8VBP3350	335	13.82
8VBP3550	355	14.64
8VBP3750	375	15.47
8VBP4000	400	16.50
8VBP4250	425	17.53
8VBP4500	450	18.56
8VBP4750	475	19.59

**MATCHED SETS:** When ordering banded belts you must specify a matched set (if required). Contact customer service for more information.

**ADDITIONAL SECTION SIZES AVAILABLE**

CONTACT CUSTOMER SERVICE FOR DETAILS.

**EXAMPLE PART NUMBERS:**

- 3/5VBP900 (3 RIBS, 5VBP900)
- 6/5VBP1400 (6 RIBS, 5VBP1400)
- 8/5VBP2650 (8 RIBS, 5VBP2650)
- 4/8VBP1000 (4 RIBS, 8VBP1000)
- 8/8VBP2240 (8 RIBS, 8VBP2240)
- 12/8VBP2000 (12 RIBS, 8VBP2000)

**EXPEDITED SHIPPING:**

Banded v-belts are available in 2-48 ribs depending on the profile size. Each OPTIBELT warehouse facility cuts banded v-belts to size to expedite customer orders.

Contact an OPTIBELT representative regarding additional sizes, stock availability and pricing.

All weights are estimated.

Additional sizes and stocking available.

**Custom Sizes & Ordering**

Section / Max. Mfg Lengths / # Ribs Per Sleeve

- 5V / 475 in. / 30
- 8V / 709 in. / 15

Must be ordered by the sleeve.

Contact customer service for details.

**Need Help?**

Contact OPTIBELT customer service.

Our friendly staff is here to assist you.

TOLL FREE: 800-292-6081

E-MAIL: [info@optibelt-usa.com](mailto:info@optibelt-usa.com)

BLUE POWER  
STANDARD BANDED



SAMPLE PART # : 4/3VRP750 **STANDARD BANDED** **3V** SECTION : 3/8"W x 25/64"H

PART NO.	OUTSIDE LENGTH (IN)	WEIGHT (LBS) (PER RIB)
3VRP500	50	.30
3VRP530	53	.32
3VRP560	56	.34
3VRP600	60	.36
3VRP630	63	.38

PART NO.	OUTSIDE LENGTH (IN)	WEIGHT (LBS) (PER RIB)
3VRP670	67	.40
3VRP710	71	.43
3VRP750	75	.45
3VRP800	80	.48
3VRP850	85	.51

PART NO.	OUTSIDE LENGTH (IN)	WEIGHT (LBS) (PER RIB)
3VRP900	90	.54
3VRP950	95	.57
3VRP1000	100	.60
3VRP1060	106	.64
3VRP1120	112	.67

PART NO.	OUTSIDE LENGTH (IN)	WEIGHT (LBS) (PER RIB)
3VRP1180	118	.71
3VRP1250	125	.75
3VRP1320	132	.79
3VRP1400	140	.84

SAMPLE PART # : 6/5VRP2500 **STANDARD BANDED** **5V** SECTION : 5/8"W x 5/8"H

PART NO.	OUTSIDE LENGTH (IN)	WEIGHT (LBS) (PER RIB)
5VRP500	50	0.42
5VRP530	53	0.74
5VRP560	56	0.78
5VRP600	60	0.84
5VRP630	63	0.88
5VRP670	67	0.94
5VRP710	71	0.99
5VRP750	75	1.05
5VRP800	80	1.12

PART NO.	OUTSIDE LENGTH (IN)	WEIGHT (LBS) (PER RIB)
5VRP850	85	1.19
5VRP900	90	1.26
5VRP950	95	1.33
5VRP1000	100	1.40
5VRP1060	106	1.48
5VRP1120	112	1.57
5VRP1180	118	1.65
5VRP1250	125	1.75

PART NO.	OUTSIDE LENGTH (IN)	WEIGHT (LBS) (PER RIB)
5VRP1320	132	1.85
5VRP1400	140	1.96
5VRP1500	150	2.10
5VRP1600	160	2.24
5VRP1700	170	2.38
5VRP1800	180	2.52
5VRP1900	190	2.66
5VRP2000	200	2.80

PART NO.	OUTSIDE LENGTH (IN)	WEIGHT (LBS) (PER RIB)
5VRP2120	212	2.97
5VRP2240	224	3.14
5VRP2360	236	3.30
5VRP2500	250	3.50
5VRP2650	265	3.71
5VRP2800	280	3.92
5VRP3000	300	4.20
5VRP3150	315	4.41

SAMPLE PART # : 4/8VRP1120 **STANDARD BANDED** **8V** SECTION : 1"W x 1-1/64"H

PART NO.	OUTSIDE LENGTH (IN)	WEIGHT (LBS) (PER RIB)
8VRP1000	100	3.90
8VRP1060	106	4.13
8VRP1120	112	4.37
8VRP1180	118	4.60
8VRP1250	125	4.88
8VRP1320	132	5.15
8VRP1400	140	5.46

PART NO.	OUTSIDE LENGTH (IN)	WEIGHT (LBS) (PER RIB)
8VRP1500	150	5.85
8VRP1600	160	6.24
8VRP1700	170	6.63
8VRP1800	180	7.02
8VRP1900	190	7.41
8VRP2000	200	7.80
8VRP2120	212	8.27

PART NO.	OUTSIDE LENGTH (IN)	WEIGHT (LBS) (PER RIB)
8VRP2240	224	8.74
8VRP2360	236	9.20
8VRP2500	250	9.75
8VRP2650	265	10.34
8VRP2800	280	10.92
8VRP3000	300	11.70
8VRP3150	315	12.29

PART NO.	OUTSIDE LENGTH (IN)	WEIGHT (LBS) (PER RIB)
8VRP3350	335	13.07
8VRP3550	355	13.85
8VRP3750	375	14.63
8VRP4000	400	15.60
8VRP4250	425	16.58
8VRP4500	450	17.55
8VRP4750	475	18.53

**MATCHED SETS:** When ordering banded belts you must specify a matched set (if required). Contact customer service for more information.

**EXAMPLE PART NUMBERS:**

- 3/5VRP900 (3 RIBS, 5VRP900)
- 6/5VRP900 (6 RIBS, 5VRP900)
- 3/5VRP900 (3 RIBS, 5VRP900)
- 8/5VRP900 (8 RIBS, 5VRP900)
- 12/5VRP900 (12 RIBS, 5VRP900)
- 8/5VRP900 (8 RIBS, 5VRP900)

**EXPEDITED SHIPPING:**  
Banded v-belts are available in 2-48 ribs depending on the profile size. Each OPTIBELT warehouse facility cuts banded v-belts to size to expedite customer orders.

**Need Help?**  
Contact OPTIBELT customer service. Our friendly staff is here to assist you.  
TOLL FREE: 800-292-6081  
E-MAIL: info@optibelt-usa.com

**Custom Sizes & Ordering**  
Section / Max. Mfg Lengths / # Ribs Per Sleeve  
• 3V / 157 in. / 40  
• 5V / 394 in. / 25  
• 8V / 708 in. / 14  
Must be ordered by the sleeve.

Contact an OPTIBELT representative regarding additional sizes, stock availability and pricing.  
All weights are estimated.  
Additional sizes and stocking available.



**SPB SECTION : 16.5mm W x 15.6mm H** **METRIC BANDED** SAMPLE PART # : 4/SPBRP4500

PART NO.	DATUM LENGTH (MM)	WEIGHT (LBS) (PER RIB)	PART NO.	DATUM LENGTH (MM)	WEIGHT (LBS) (PER RIB)	PART NO.	DATUM LENGTH (MM)	WEIGHT (LBS) (PER RIB)	PART NO.	DATUM LENGTH (MM)	WEIGHT (LBS) (PER RIB)
SPBRP2000	2000	2.30	SPBRP3000	3000	3.45	SPBRP4250	4250	4.89	SPBRP6000	6000	6.90
SPBRP2120	2120	2.44	SPBRP3150	3150	3.62	SPBRP4500	4500	5.18	SPBRP6300	6300	7.25
SPBRP2240	2240	2.58	SPBRP3350	3350	3.85	SPBRP4750	4750	5.46	SPBRP6700	6700	7.71
SPBRP2360	2360	2.71	SPBRP3550	3550	4.08	SPBRP5000	5000	5.75	SPBRP7100	7100	8.17
SPBRP2500	2500	2.88	SPBRP3750	3750	4.31	SPBRP5300	5300	6.10	SPBRP7500	7500	8.63
SPBRP2650	2650	3.05	SPBRP4000	4000	4.60	SPBRP5600	5600	6.44	SPBRP8000	8000	9.36
SPBRP2800	2800	3.22									

**SPC SECTION : 22mm W x 22.6mm H** **METRIC BANDED** SAMPLE PART # : 6/SPCRP7100

PART NO.	DATUM LENGTH (MM)	WEIGHT (LBS) (PER RIB)	PART NO.	DATUM LENGTH (MM)	WEIGHT (LBS) (PER RIB)	PART NO.	DATUM LENGTH (MM)	WEIGHT (LBS) (PER RIB)	PART NO.	DATUM LENGTH (MM)	WEIGHT (LBS) (PER RIB)
SPCRP3000	3000	3.45	SPCRP4250	4250	4.89	SPCRP6000	6000	6.90	SPCRP8000	8000	9.20
SPCRP3150	3150	3.62	SPCRP4500	4500	5.18	SPCRP6300	6300	7.25	SPCRP8500	8500	9.78
SPCRP3350	3350	3.85	SPCRP4750	4750	5.46	SPCRP6700	6700	7.71	SPCRP9000	9000	10.35
SPCRP3550	3550	4.08	SPCRP5000	5000	5.75	SPCRP7100	7100	8.17	SPCRP9500	9500	10.93
SPCRP3750	3750	4.31	SPCRP5300	5300	6.10	SPCRP7500	7500	8.63	SPCRP10000	10000	11.50
SPCRP4000	4000	4.60	SPCRP5600	5600	6.44						

**MATCHED SETS:** When ordering banded belts you must specify a matched set (if required). Contact customer service for more information.

**ADDITIONAL SECTION SIZES AVAILABLE**  
CONTACT CUSTOMER SERVICE FOR DETAILS.

**EXAMPLE PART NUMBERS:**

- 3/SPBRP3350 (3 RIBS, SPBRP3350)    • 6/SPBRP6300 (6 RIBS, SPBRP6300)
- 6/SPCRP3750 (6 RIBS, SPCRP3750)    • 8/SPCRP7100 (8 RIBS, SPCRP7100)

**EXPEDITED SHIPPING:**

Banded v-belts are available in 2-48 ribs depending on the profile size. Each OPTIBELT warehouse facility cuts banded v-belts to size to expedite customer orders.

Contact an OPTIBELT representative regarding additional sizes, stock availability and pricing.

All weights are estimated.

Additional sizes and stocking available.

**Custom Sizes & Ordering**  
Section / Max. Mfg Lengths / # Ribs Per Sleeve

- SPB / 10,000 mm / 22
- SPC / 10,000 mm / 16

Must be ordered by the sleeve.  
Contact customer service for details.

**Need Help?**

Contact OPTIBELT customer service.  
Our friendly staff is here to assist you.  
TOLL FREE: 800-292-6081  
E-MAIL: [info@optibelt-usa.com](mailto:info@optibelt-usa.com)



CLASSIC BANDED KB

SAMPLE PART # : 8/B60

**CLASSIC BANDED**

**B** SECTION : 21/32"W x 1/2"H

PART NO.	OUTSIDE LENGTH (IN)	WEIGHT (LBS)
B48	51	1.43
B50	53	1.49
B51	54	1.52
B52	55	1.56
B53	56	1.59
B54	57	1.62
B55	58	1.64
B56	59	1.67
B57	60	1.70
B58	61	1.72
B59	62	1.76
B60	63	1.80
B61	64	1.82
B62	65	1.84
B63	66	1.87
B64	67	1.90
B65	68	1.93
B66	69	1.96

PART NO.	OUTSIDE LENGTH (IN)	WEIGHT (LBS)
B67	70	1.99
B68	71	2.02
B70	73	2.08
B71	74	2.12
B72	75	2.15
B73	76	2.18
B74	77	2.21
B75	78	2.24
B77	80	2.30
B78	81	2.33
B79	82	2.36
B80	83	2.39
B81	84	2.42
B82	85	2.45
B83	86	2.48
B85	88	2.54
B86	89	2.57
B87	90	2.60

PART NO.	OUTSIDE LENGTH (IN)	WEIGHT (LBS)
B88	91	2.63
B90	93	2.69
B93	96	2.78
B95	98	2.84
B96	99	2.87
B97	100	2.90
B99	102	2.95
B100	103	2.99
B103	106	3.08
B105	108	3.14
B108	111	3.22
B112	115	3.34
B116	119	3.46
B120	123	3.58
B124	127	3.70
B128	131	3.82
B133	136	3.97

PART NO.	OUTSIDE LENGTH (IN)	WEIGHT (LBS)
B136	139	4.05
B140	143	4.17
B144	147	4.29
B148	151	4.41
B150	153	4.47
B158	161	4.71
B162	165	4.83
B173	176	5.15
B180	183	5.36
B195	198	5.81
B210	213	6.26
B225	228	6.66
B240	243	7.10
B255	258	7.60
B270	273	7.99
B300	303	8.89
B315	318	9.33

SAMPLE PART # : 6/C270

**CLASSIC BANDED**

**C** SECTION : 7/8"W x 5/8"H

PART NO.	OUTSIDE LENGTH (IN)	WEIGHT (LBS)
C81	85	4.31
C85	89	4.51
C90	94	4.77
C96	100	5.07
C99	103	5.22
C100	104	5.27
C105	109	5.42
C108	112	5.47
C109	113	5.62

PART NO.	OUTSIDE LENGTH (IN)	WEIGHT (LBS)
C112	116	5.77
C115	119	6.02
C120	124	6.22
C124	128	6.42
C128	132	6.82
C136	140	7.22
C144	148	7.92
C158	162	8.12
C162	166	8.67

PART NO.	OUTSIDE LENGTH (IN)	WEIGHT (LBS)
C173	177	9.02
C180	184	9.77
C195	199	10.52
C210	214	11.17
C225	229	11.92
C240	244	12.67
C255	259	13.42
C270	274	14.17

PART NO.	OUTSIDE LENGTH (IN)	WEIGHT (LBS)
C285	289	14.91
C300	304	15.66
C315	319	16.41
C330	334	16.79
C345	349	17.16
C360	364	17.91
C390	394	19.41
C420	424	20.91

**MATCHED SETS:** When ordering banded belts you must specify a matched set (if required). Contact customer service for more information.

**EXAMPLE PART NUMBERS:**

- 3/B58 (3 RIBS, B58)
- 4/C144 (4 RIBS, C144)
- 6/B105 (6 RIBS, B105)
- 8/C360 (8 RIBS, C360)

**EXPEDITED SHIPPING:**

Banded v-belts are available in 2-48 ribs depending on the profile size. Each OPTIBELT warehouse facility cuts banded v-belts to size to expedite customer orders.

**Need Help?**  
Contact OPTIBELT customer service. Our friendly staff is here to assist you.  
TOLL FREE: 800-292-6081  
E-MAIL: info@optibelt-usa.com

**Custom Sizes & Ordering**  
Section / Max. Mfg Lengths / # Ribs Per Sleeve

- B / 708 in. / 27
- C / 708 in. / 20

Must be ordered by the sleeve.  
Contact customer service for details.

Contact an OPTIBELT representative regarding additional sizes, stock availability and pricing.  
All weights are estimated.  
Additional sizes and stocking available.



D SECTION : 1-1/4"W x 7/8"H

**CLASSIC BANDED**

SAMPLE PART # : 5/D240

PART NO.	OUTSIDE LENGTH (IN)	WEIGHT (LBS) (PER RIB)
D105	110	9.05
D120	125	10.63
D128	133	11.28
D140	145	12.57
D144	149	12.86
D158	163	14.11
D162	167	14.78

PART NO.	OUTSIDE LENGTH (IN)	WEIGHT (LBS) (PER RIB)
D173	178	15.45
D180	188	16.07
D195	200	17.41
D210	215	18.75
D225	230	19.86
D240	245	21.20
D255	260	22.54

PART NO.	OUTSIDE LENGTH (IN)	WEIGHT (LBS) (PER RIB)
D270	275	23.88
D285	290	25.21
D300	305	26.55
D315	320	27.89
D330	335	29.23
D345	350	30.56

PART NO.	OUTSIDE LENGTH (IN)	WEIGHT (LBS) (PER RIB)
D360	365	31.91
D390	395	34.59
D420	425	37.27
D540	545	47.96
D600	605	53.31
D660	665	58.66

**ORDERING:** D SECTION BANDED SIZES MUST BE ORDERED IN FULL SLEEVE QUANTITIES (10 RIBS)

**MATCHED SETS:** When ordering banded belts you must specify a matched set (if required). Contact customer service for more information.

**EXAMPLE PART NUMBERS:**

- 3/D120 (3 RIBS, D120)
- 4/D240 (4 RIBS, D240)
- 6/D255 (6 RIBS, D255)
- 8/D600 (8 RIBS, D600)

**EXPEDITED SHIPPING:**

Banded v-belts are available in 2-48 ribs depending on the profile size. Each OPTIBELT warehouse facility cuts banded v-belts to size to expedite customer orders.

**KB**  
CLASSIC BANDED

OPTIBELT representative regarding additional sizes, stock availability and pricing.

All weights are estimated.

Additional sizes and stocking available.

**Custom Sizes & Ordering**

Section / Max. Mfg Lengths / # Ribs Per Sleeve

- D / 708 in. (18,000 mm) / 10

Must be ordered by the sleeve.

Contact customer service for details.

**Need Help?**

Contact OPTIBELT customer service.

Our friendly staff is here to assist you.

TOLL FREE: 800-292-6081

E-MAIL: [info@optibelt-usa.com](mailto:info@optibelt-usa.com)





SAMPLE PART # : 4/3V750

### CLASSIC BANDED

3V SECTION : 3/8"W x 25/64"H

PART NO.	OUTSIDE LENGTH (IN)	WEIGHT (LBS)
3V450	45	0.61
3V475	47.5	0.65
3V500	50	0.68
3V530	53	0.72
3V560	56	0.76
3V600	60	0.82

PART NO.	OUTSIDE LENGTH (IN)	WEIGHT (LBS)
3V630	63	0.86
3V670	67	0.91
3V710	71	0.97
3V750	75	1.02
3V800	80	1.09

PART NO.	OUTSIDE LENGTH (IN)	WEIGHT (LBS)
3V850	85	1.16
3V900	90	1.23
3V950	95	1.30
3V1000	100	1.36
3V1060	106	1.45

PART NO.	OUTSIDE LENGTH (IN)	WEIGHT (LBS)
3V1120	112	1.53
3V1180	118	1.61
3V1250	125	1.71
3V1320	132	1.80
3V1400	140	1.91

SAMPLE PART # : 5/5V2500

### CLASSIC BANDED

5V SECTION : 5/8"W x 5/8"H

PART NO.	OUTSIDE LENGTH (IN)	WEIGHT (LBS)
5V500	50	1.41
5V530	53	1.49
5V560	56	1.58
5V600	60	1.69
5V630	63	1.77
5V670	67	1.89
5V710	71	2.00
5V750	75	2.11
5V800	80	2.25

PART NO.	OUTSIDE LENGTH (IN)	WEIGHT (LBS)
5V850	85	2.39
5V900	90	2.53
5V950	95	2.68
5V1000	100	2.82
5V1060	106	2.99
5V1120	112	3.15
5V1180	118	3.32
5V1250	125	3.52
5V1320	132	3.72

PART NO.	OUTSIDE LENGTH (IN)	WEIGHT (LBS)
5V1400	140	3.94
5V1500	150	4.22
5V1600	160	4.51
5V1700	170	4.79
5V1800	180	5.07
5V1900	190	5.35
5V2000	200	5.63
5V2120	212	5.97
5V2240	224	6.31

PART NO.	OUTSIDE LENGTH (IN)	WEIGHT (LBS)
5V2360	236	6.65
5V2500	250	7.04
5V2650	265	7.46
5V2800	280	7.88
5V3000	300	8.45
5V3150	315	8.87
5V3350	335	9.44
5V3550	355	10.00

SAMPLE PART # : 6/8V1700

### CLASSIC BANDED

8V SECTION : 1"W x 1-1/64"H

PART NO.	OUTSIDE LENGTH (IN)	WEIGHT (LBS)
8V1000	100	7.74
8V1060	106	8.21
8V1120	112	8.67
8V1180	118	9.14
8V1250	125	9.68
8V1320	132	10.22
8V1400	140	10.84
8V1500	150	11.62

PART NO.	OUTSIDE LENGTH (IN)	WEIGHT (LBS)
8V1600	160	12.39
8V1700	170	13.17
8V1800	180	13.94
8V1900	190	14.72
8V2000	200	15.49
8V2120	212	16.42
8V2240	224	17.35
8V2360	236	18.28

PART NO.	OUTSIDE LENGTH (IN)	WEIGHT (LBS)
8V2500	250	19.36
8V2650	265	20.52
8V2800	280	21.69
8V3000	300	23.23
8V3150	315	24.40
8V3350	335	25.94
8V3550	355	27.50
8V3750	375	29.04

PART NO.	OUTSIDE LENGTH (IN)	WEIGHT (LBS)
8V4000	400	30.98
8V4250	425	32.92
8V4500	450	34.85
8V4750	475	36.79
8V5000	500	38.73
8V5600	560	43.37
8V6000	600	46.47

**MATCHED SETS:** When ordering banded belts you must specify a matched set (if required). Contact customer service for more information.

**EXAMPLE PART NUMBERS:**

- 3/3V560 (3 RIBS, 3V560)
- 6/5V500 (6 RIBS, 5V500)
- 6/8V2120 (6 RIBS, 8V2120)
- 4/3V1180 (4 RIBS, 3V1180)
- 8/5V1700 (8 RIBS, 5V1700)
- 8/8V4000 (8 RIBS, 8V4000)

**EXPEDITED SHIPPING:**

Banded v-belts are available in 2-48 ribs depending on the profile size. Each OPTIBELT warehouse facility cuts banded v-belts to size to expedite customer orders.

**Need Help?**  
Contact OPTIBELT customer service. Our friendly staff is here to assist you.  
TOLL FREE: 800-292-6081  
E-MAIL: info@optibelt-usa.com

**Custom Sizes & Ordering**  
Section / Max. Mfg Lengths / # Ribs Per Sleeve

- 3V / 167 in. (4250 mm) / 48
- 5V / 393 in. (10000 mm) / 30
- 8V / 708in. (18000 mm) / 15

Must be ordered by the sleeve.

Contact an OPTIBELT representative regarding additional sizes, stock availability and pricing.  
All weights are estimated.  
Additional sizes and stocking available upon request



**SPZ SECTION : 9.7mm W x 10.5mm H**

**METRIC BANDED**

SAMPLE PART # : 6/SPZ2650

PART NO.	DATUM LENGTH (MM)	WEIGHT (LBS) (PER RIB)
SPZ1250	1250	0.66
SPZ1400	1400	0.74
SPZ1500	1500	0.79
SPZ1600	1600	0.84
SPZ1700	1700	0.90

PART NO.	DATUM LENGTH (MM)	WEIGHT (LBS) (PER RIB)
SPZ1800	1800	0.95
SPZ1900	1900	1.00
SPZ2000	2000	1.06
SPZ2120	2120	1.12
SPZ2240	2240	1.18

PART NO.	DATUM LENGTH (MM)	WEIGHT (LBS) (PER RIB)
SPZ2360	2360	1.25
SPZ2500	2500	1.32
SPZ2650	2650	1.40
SPZ2800	2800	1.48

PART NO.	DATUM LENGTH (MM)	WEIGHT (LBS) (PER RIB)
SPZ3000	3000	1.58
SPZ3150	3150	1.66
SPZ3350	3350	1.77
SPZ3550	3550	1.87

**SPA SECTION : 12.7mm W x 12.5mm H**

**METRIC BANDED**

SAMPLE PART # : 4/SPA1500

PART NO.	DATUM LENGTH (MM)	WEIGHT (LBS) (PER RIB)
SPA1250	1250	0.91
SPA1400	1400	1.02
SPA1500	1500	1.10
SPA1600	1600	1.17
SPA1700	1700	1.24
SPA1800	1800	1.32

PART NO.	DATUM LENGTH (MM)	WEIGHT (LBS) (PER RIB)
SPA1900	1900	1.39
SPA2000	2000	1.46
SPA2120	2120	1.55
SPA2240	2240	1.64
SPA2360	2360	1.72
SPA2500	2500	1.83

PART NO.	DATUM LENGTH (MM)	WEIGHT (LBS) (PER RIB)
SPA2650	2650	1.94
SPA2800	2800	2.05
SPA3000	3000	2.19
SPA3150	3150	2.30
SPA3350	3350	2.45

PART NO.	DATUM LENGTH (MM)	WEIGHT (LBS) (PER RIB)
SPA3550	3550	2.59
SPA3750	3750	2.74
SPA4000	4000	2.92
SPA4250	4250	3.10
SPA4500	4500	3.29

**SPB SECTION : 16.5mm W x 15.6mm H**

**METRIC BANDED**

SAMPLE PART # : 6/SPB4750

PART NO.	DATUM LENGTH (MM)	WEIGHT (LBS) (PER RIB)
SPB2000	2000	2.30
SPB2120	2120	2.44
SPB2240	2240	2.57
SPB2360	2360	2.71
SPB2500	2500	2.87
SPB2650	2650	3.04
SPB2800	2800	3.22

PART NO.	DATUM LENGTH (MM)	WEIGHT (LBS) (PER RIB)
SPB3000	3000	3.45
SPB3150	3150	3.62
SPB3350	3350	3.85
SPB3550	3550	4.08
SPB3750	3750	4.31
SPB4000	4000	4.59

PART NO.	DATUM LENGTH (MM)	WEIGHT (LBS) (PER RIB)
SPB4250	4250	4.88
SPB4500	4500	5.17
SPB4750	4750	5.46
SPB5000	5000	5.74
SPB5300	5300	6.09
SPB5600	5600	6.43

PART NO.	DATUM LENGTH (MM)	WEIGHT (LBS) (PER RIB)
SPB6000	6000	6.89
SPB6300	6300	7.24
SPB6700	6700	7.69
SPB7100	7100	8.15
SPB7500	7500	8.61
SPB8000	8000	9.19

**MATCHED SETS:** When ordering banded belts you must specify a matched set (if required). Contact customer service for more information.

**EXAMPLE PART NUMBERS:**

- 3/SPZ1500 (3 RIBS, SPZ1500)
- 6/SPA2120 (6 RIBS, SPA2120)
- 4/SPB3350 (4 RIBS, SPB3350)
- 4/SPZ2650 (4 RIBS, SPZ2650)
- 8/SPA3000 (8 RIBS, SPA3000)
- 10/SPB7500 (10 RIBS, SPB7500)

**EXPEDITED SHIPPING:**

Banded v-belts are available in 2-48 ribs depending on the profile size. Each OPTIBELT warehouse facility cuts banded v-belts to size to expedite customer orders.

OPTIBELT representative regarding additional sizes, stock availability and pricing.

All weights are estimated.

Additional sizes and stocking available.

**Custom Sizes & Ordering**

Section / Max. Mfg Lengths / # Ribs Per Sleeve

- SPZ / 4500 mm / 36-42
- SPA / 4500 mm / 28-33
- SPB / 10000 mm / 22

Must be ordered by the sleeve.

**Need Help?**

Contact OPTIBELT customer service.  
Our friendly staff is here to assist you.  
TOLL FREE: 800-292-6081  
E-MAIL: info@optibelt-usa.com



SAMPLE PART # : 4/SPC3550

**METRIC BANDED**

SPC SECTION : 22mm W x 22.6mm H

PART NO.	DATUM LENGTH (MM)	WEIGHT (LBS) (PER RIB)
SPC3000	3000	7.33
SPC3150	3150	7.69
SPC3350	3350	8.18
SPC3550	3550	8.67
SPC3750	3750	9.16

PART NO.	DATUM LENGTH (MM)	WEIGHT (LBS) (PER RIB)
SPC4000	4000	9.77
SPC4250	4250	10.38
SPC4500	4500	10.99
SPC4750	4750	11.60
SPC5000	5000	12.21

PART NO.	DATUM LENGTH (MM)	WEIGHT (LBS) (PER RIB)
SPC5300	5300	12.94
SPC5600	5600	13.68
SPC6000	6000	14.65
SPC6300	6300	15.38
SPC6700	6700	16.36

PART NO.	DATUM LENGTH (MM)	WEIGHT (LBS) (PER RIB)
SPC7100	7100	17.34
SPC7500	7500	18.32
SPC8000	8000	19.54
SPC8500	8500	20.76
SPC9000	9000	21.98

**MATCHED SETS:** When ordering banded belts you must specify a matched set (if required). Contact customer service for more information.

**EXAMPLE PART NUMBERS:**

- 4/SPC5300 (4 RIBS, SPC5300)
- 8/SPB7100 (8 RIBS, SPB7100)

**EXPEDITED SHIPPING:**

Banded v-belts are available in 2-48 ribs depending on the profile size. Each OPTIBELT warehouse facility cuts banded v-belts to size to expedite customer orders.

METRIC BANDED  
KB

**Need Help?**

Contact OPTIBELT customer service.  
Our friendly staff is here to assist you.  
TOLL FREE: 800-292-6081  
E-MAIL: info@optibelt-usa.com

**Custom Sizes & Ordering**

Section / Max. Mfg Lengths / # Ribs Per Sleeve

- SPC / 12500 mm / 16

Must be ordered by the sleeve.  
Contact customer service for details.

Contact an OPTIBELT representative regarding additional sizes, stock availability and pricing.

All weights are estimated.

Additional sizes and stocking available upon request



**BX SECTION : 21/32"W x 1/2"H**

**CLASSIC BANDED**

SAMPLE PART # : 4/BX75

PART NO.	OUTSIDE LENGTH (IN)	WEIGHT (LBS) (PER RIB)
BX55	58	1.61
BX58	61	1.70
BX59	62	1.73
BX60	63	1.76
BX61	64	1.78
BX62	65	1.81
BX65	68	1.90

PART NO.	OUTSIDE LENGTH (IN)	WEIGHT (LBS) (PER RIB)
BX66	69	1.93
BX68	71	1.98
BX70	73	2.04
BX75	78	2.18
BX77	80	2.23
BX78	81	2.27

PART NO.	OUTSIDE LENGTH (IN)	WEIGHT (LBS) (PER RIB)
BX79	82	2.29
BX80	83	2.33
BX85	88	2.47
BX90	93	2.61
BX93	96	2.69
BX95	98	2.75

PART NO.	OUTSIDE LENGTH (IN)	WEIGHT (LBS) (PER RIB)
BX97	100	2.81
BX100	103	2.90
BX103	106	2.98
BX105	108	3.04
BX108	111	3.13
BX112	115	3.24

BX kraftband sections are a non-stocked item. Contact customer service for ordering information.

**KBX**  
COGGED BANDED

**3VX SECTION : 3/8"W x 25/64"H**

**STANDARD BANDED**

SAMPLE PART # : 4/3VX750

PART NO.	OUTSIDE LENGTH (IN)	WEIGHT (LBS) (PER RIB)
3VX425	42.5	.61
3VX475	47.5	.65
3VX500	50	.68
3VX530	53	.72
3VX560	56	.76
3VX600	60	.82

PART NO.	OUTSIDE LENGTH (IN)	WEIGHT (LBS) (PER RIB)
3VX630	63	.86
3VX670	67	.91
3VX710	71	.97
3VX750	75	1.02
3VX800	80	1.09

PART NO.	OUTSIDE LENGTH (IN)	WEIGHT (LBS) (PER RIB)
3VX850	85	1.16
3VX900	90	1.23
3VX950	95	1.30
3VX1000	100	1.36
3VX1060	106	1.45

PART NO.	OUTSIDE LENGTH (IN)	WEIGHT (LBS) (PER RIB)
3VX1120	112	1.53
3VX1180	118	1.61
3VX1250	125	1.71
3VX1320	132	1.80
3VX1400	140	1.91

**5VX SECTION : 5/8"W x 5/8"H**

**STANDARD BANDED**

SAMPLE PART # : 5/5VX750

PART NO.	OUTSIDE LENGTH (IN)	WEIGHT (LBS) (PER RIB)
5VX500	50	.5
5VX530	53	.53
5VX560	56	.56
5VX600	60	.6
5VX630	63	.63
5VX670	67	.67
5VX710	71	.71

PART NO.	OUTSIDE LENGTH (IN)	WEIGHT (LBS) (PER RIB)
5VX750	75	.75
5VX800	80	.8
5VX850	85	.85
5VX900	90	.9
5VX950	95	.95
5VX1000	100	1

PART NO.	OUTSIDE LENGTH (IN)	WEIGHT (LBS) (PER RIB)
5VX1060	106	1.06
5VX1120	112	1.12
5VX1180	118	1.18
5VX1250	125	1.25
5VX1320	132	1.32
5VX1400	140	1.4

PART NO.	OUTSIDE LENGTH (IN)	WEIGHT (LBS) (PER RIB)
5VX1500	150	1.5
5VX1600	160	1.6
5VX1700	170	1.7
5VX1800	180	1.8
5VX1900	190	1.9
5VX2000	200	2

**MATCHED SETS:** When ordering banded belts you must specify a matched set (if required). Contact customer service for more information.

**EXAMPLE PART NUMBERS:**

- 3/BX62 (3 RIBS, BX62)
- 6/3VX630 (6 RIBS, 3VX630)
- 4/5VX950 (4 RIBS, 5VX950)
- 4/BX100 (4 RIBS, BX100)
- 8/3VX1180 (8 RIBS, 3VX1180)
- 10/5VX1250 (10 RIBS, 5VX1250)

**EXPEDITED SHIPPING:**

Banded v-belts are available in 2-48 ribs depending on the profile size. Each OPTIBELT warehouse facility cuts banded v-belts to size to expedite customer orders.

**ADDITIONAL SIZES AVAILABLE. CONTACT CUSTOMER SERVICE FOR DETAILS.**

Contact and OPTIBELT representative regarding additional sizes, stock availability and pricing.

All weights are estimated.

Additional sizes and stocking available.

**Custom Sizes & Ordering**

Section / Max. Mfg Lengths / # Ribs Per Sleeve

- BX / 178 in. / 27-44
- 3VX / 140 in. / 48 or 84
- 5VX / 140 in. / 64

Must be ordered by the sleeve.

**Need Help?**

Contact OPTIBELT customer service. Our friendly staff is here to assist you.  
TOLL FREE: 800-292-6081  
E-MAIL: info@optibelt-usa.com



VARIO POWER are the preferred choice for demanding infinite variable speed control drives. The unique belt structure is designed to handle highly dynamic loads and transfer more power than conventional variable-speed belts

- **Performance** : Capable of transferring heavy loads.
- **Extended Life** : Low-stretch fiberglass cords resist stretching and specialized abrasion-resistant bonded fabric cover for longer belt life.
- **Temperature Range** : Increased ranges from -22 to 212°F.
- **Increased Flex Range** : Capable of running on smaller sheaves than conventional variable speed belts.

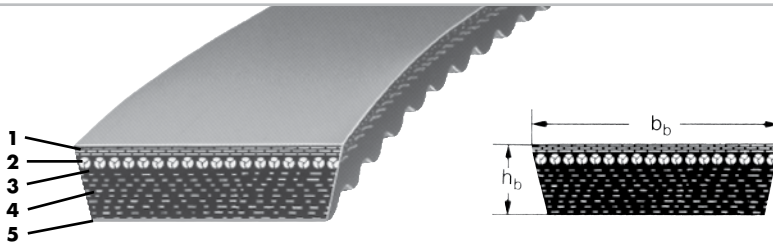

1. Belt outer surface 2. Fiberglass tension cord 3. Cushion compound  
4. Fiber reinforced core 5. Wrapped molded cogs

**NOMINAL DIMENSIONS OF US STANDARD**

SECTION	b <sub>b</sub>		h <sub>b</sub>	
	(IN)	(MM)	(IN)	(MM)
1422 V	.88	22.35	.31	7.87
1922 V	1.19	30.23	.38	9.65
2322 V	1.44	36.58	.44	11.18
1926 V	1.19	30.23	.44	11.18
2926 V	1.81	45.97	.5	12.7
3226 V	2.00	50.80	.53	13.46
2530 V	1.56	39.62	.59	14.99
3230 V	2.00	60.80	.62	15.75
4430 V	2.75	69.85	.69	17.53
4036 V	2.50	63.50	.69	17.53
4436 V	2.75	69.85	.72	18.29
4836 V	3.00	76.20	.75	19.05

**ORDERING GUIDE (US STANDARD)**

The belt number is a complete description of the belt. For example: 4430V970

44 Top width in 16ths of an inch: 48/16" = 3

30 Angle of sheave groove = 30°

V Indicates "Variable Speed"

970 Pitch Length in 10th's of an inch = 97"

**VARIO POWER**  
SPECIALTY

U.S. STANDARD

**VARIABLE SPEED**

VARIABLE SPEED, MOLDED COGGED

PART NO.	PART NO.	PART NO.	PART NO.	PART NO.	PART NO.	PART NO.	PART NO.
1422V235	1922V332	1922V544	2322V364	2330V273	2926V586	3226V663	4430V690
1422V300	1922V338	1922V604	2322V421	2430V345	2926V606	3226V783	4430V700
1422V360	1922V363	1926V427	2322V441	2530V660	2926V666	3230HV821	4430V730
1422V420	1922V403	2230V273	2322V481	2530V670	2926V686	3230HV856	4430V790
1422V660	1922V426	2230V275	2322V521	2830V363	2926V834	3230HV931	4430V850
1430V215	1922V443	2230V285	2322V541	2830V367	3226V392	3432V456	4430V970
1628V210	1922V454	2230V326	2322V601	2830V393	3226V514	4230V556	
1922V298	1922V484	2322V329	2322V681	2926V486	3226V585	4430V610	
1922V321	1922V526	2322V347	2326V310	2926V521	3226V603	4430V630	

**ADDITIONAL SIZES AVAILABLE. CONTACT CUSTOMER SERVICE FOR DETAILS.**

**Need Help?**

Contact OPTIBELT customer service.  
Our friendly staff is here to assist you.  
TOLL FREE: 800-292-6081  
E-MAIL: info@optibelt-usa.com

**Custom Sizes & Ordering**

Minimum production quantity applies.  
Contact customer service for maximum manufacturing lengths and details.

Contact an OPTIBELT representative regarding additional sizes, stock availability and pricing.

All weights are estimated.  
Additional sizes and stocking available.



# optibelt VARIO POWER

## VARIABLE SPEED BELTS

### METRIC VARIABLE SPEED

SAMPLE PART #: 30X10X1000

PART NO.	SECTION W x D (MM)	INSIDE LENGTH (MM)	PART NO.	SECTION W x D (MM)	INSIDE LENGTH (MM)	PART NO.	SECTION W x D (MM)	INSIDE LENGTH (MM)	PART NO.	SECTION W x D (MM)	INSIDE LENGTH (MM)
13X5X468	13 x 5	468	28X8X600	28 x 8	600	32X10X850	32 x 10	850	41X13X1740	41 x 13	1740
13X5X500	13 x 5	500	28X8X650	28 x 8	650	32X10X900	32 x 10	900	41X13X1940	41 x 13	1940
17X5X426	17 x 5	426	28X8X700	28 x 8	700	32X10X950	32 x 10	950	47X13X1000	47 x 13	1000
17X5X476	17 x 5	476	28X8X750	28 x 8	750	32X10X1000	32 x 10	1000	47X13X1060	47 x 13	1060
17X5X536	17 x 5	536	28X8X800	28 x 8	800	32X10X1073	32 x 10	1073	47X13X1120	47 x 13	1120
17X5X570	17 x 5	570	28X8X850	28 x 8	850	32X10X1120	32 x 10	1120	47X13X1180	47 x 13	1180
17X5X606	17 x 5	606	28X8X900	28 x 8	900	32X10X1180	32 x 10	1180	47X13X1250	47 x 13	1250
17X5X776	17 x 5	776	28X8X950	28 x 8	950	32X10X1200	32 x 10	1200	47X13X1320	47 x 13	1320
21X6X530	21 x 6	530	28X8X1000	28 x 8	1000	32X10X1353	32 x 10	1353	47X13X1400	47 x 13	1400
21X6X600	21 x 6	600	28X8X1060	28 x 8	1060	37X10X660	37 x 10	660	47X13X1500	47 x 13	1500
21X6X610	21 x 6	610	28X8X1120	28 x 8	1120	37X10X800	37 x 10	800	47X13X1600	47 x 13	1600
21X6X675	21 x 6	675	28X8X1180	28 x 8	1180	37X10X850	37 x 10	850	47X13X1700	47 x 13	1700
21X6X770	21 x 6	770	28X8X1250	28 x 8	1250	37X10X900	37 x 10	900	47X13X1800	47 x 13	1800
21X6X870	21 x 6	870	28X8X1320	28 x 8	1320	37X10X950	37 x 10	950	52X16X1180	52 x 16	1180
21X6X970	21 x 6	970	28X8X1400	28 x 8	1400	37X10X1000	37 x 10	1000	52X16X1250	52 x 16	1250
21X6X1220	21 x 6	1220	28X8X1450	28 x 8	1450	37X10X1020	37 x 10	1020	52X16X1325	52 x 16	1325
22X8X485	22 x 8	485	28X8X1500	28 x 8	1500	37X10X1060	37 x 10	1060	52X16X1400	52 x 16	1400
22X8X525	22 x 8	525	30X10X650	30 x 10	650	37X10X1120	37 x 10	1120	52X16X1525	52 x 16	1525
22X8X565	22 x 8	565	30X10X665	30 x 10	665	37X10X1180	37 x 10	1180	52X16X1600	52 x 16	1600
22X8X650	22 x 8	650	30X10X700	30 x 10	700	37X10X1250	37 x 10	1250	52X16X1725	52 x 16	1725
22X8X700	22 x 8	700	30X10X800	30 x 10	800	37X10X1320	37 x 10	1320	52X16X1925	52 x 16	1925
22X8X750	22 x 8	750	30X10X850	30 x 10	850	37X10X1400	37 x 10	1400	52X16X2165	52 x 16	2165
22X8X800	22 x 8	800	30X10X875	30 x 10	875	37X10X1500	37 x 10	1500	52X16X2240	52 x 16	2240
22X8X850	22 x 8	850	30X10X900	30 x 10	900	37X10X1600	37 x 10	1600	55X16X1400	55 x 16	1400
22X8X900	22 x 8	900	30X10X950	30 x 10	950	37X10X1700	37 x 10	1700	55X16X1500	55 x 16	1500
22X8X950	22 x 8	950	30X10X1000	30 x 10	1000	37X10X1800	37 x 10	1800	55X16X1600	55 x 16	1600
22X8X1000	22 x 8	1000	30X10X1035	30 x 10	1035	41X13X925	41 x 13	925	55X16X1700	55 x 16	1700
22X8X1060	22 x 8	1060	30X10X1050	30 x 10	1050	41X13X1000	41 x 13	1000	55X16X1800	55 x 16	1800
22X8X1185	22 x 8	1185	30X10X1120	30 x 10	1120	41X13X1040	41 x 13	1040	65X20X1706	65 x 20	1706
26X8X655	26 x 8	655	30X10X1200	30 x 10	1200	41X13X1060	41 x 13	1060	65X20X1906	65 x 20	1906
26X8X672	26 x 8	672	30X10X1320	30 x 10	1320	41X13X1120	41 x 13	1120	70X18X1600	70 x 18	1600
26X8X710	26 x 8	710	30X10X1340	30 x 10	1340	41X13X1180	41 x 13	1180	70X18X1700	70 x 18	1700
26X8X750	26 x 8	750	30X10X1500	30 x 10	1500	41X13X1190	41 x 13	1190	70X18X1800	70 x 18	1800
26X8X762	26 x 8	762	30X10X1600	30 x 10	1600	41X13X1250	41 x 13	1250	70X18X1900	70 x 18	1900
26X8X800	26 x 8	800	32X10X750	32 x 10	750	41X13X1340	41 x 13	1340	70X18X2000	70 x 18	2000
26X8X862	26 x 8	862	32X10X790	32 x 10	790	41X13X1440	41 x 13	1440	70X18X2240	70 x 18	2240
26X8X962	26 x 8	962	32X10X820	32 x 10	820	41X13X1600	41 x 13	1600	70X18X2500	70 x 18	2500
26X8X1082	26 x 8	1082									

VARIO POWER  
SPECIALTY

Contact an OPTIBELT representative regarding additional sizes, stock availability and pricing.

All weights are estimated.

Additional sizes and stocking available.

#### Custom Sizes & Ordering

Minimum production quantity applies.

Contact customer service for maximum manufacturing lengths and details.

**Metric Sizes:** Top width x depth x length

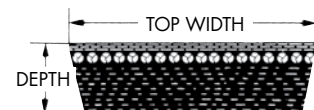



SAMPLE PART # : AA60

**DOUBLE V-BELTS**

**AA** SECTION : 1/2"W x 3/8"H

PART NO.	WEIGHT (LBS)
AA51	.41
AA55	.44
AA60	.48
AA64	.51
AA66	.53

PART NO.	WEIGHT (LBS)
AA68	.55
AA70	.56
AA75	.6
AA80	.64
AA85	.68

PART NO.	WEIGHT (LBS)
AA90	.72
AA92	.74
AA96	.77
AA105	.84
AA108	.86

PART NO.	WEIGHT (LBS)
AA112	.90
AA118	.94
AA120	.96
AA128	1.02
AA148	1.18

SAMPLE PART # : BB190

**DOUBLE V-BELTS**

**BB** SECTION : 21/32"W x 1/2"H

PART NO.	WEIGHT (LBS)
BB42	.59
BB43	.60
BB45	.63
BB53	.74
BB55	.77
BB60	.84
BB68	.95
BB71	.99
BB72	1.01
BB73	1.02
BB74	1.04
BB75	1.05
BB76	1.06
BB81	1.13
BB83	1.16
BB85	1.19

PART NO.	WEIGHT (LBS)
BB90	1.26
BB91	1.27
BB92	1.29
BB93	1.30
BB94	1.32
BB95	1.33
BB96	1.34
BB97	1.36
BB100	1.40
BB103	1.44
BB105	1.47
BB107	1.50
BB108	1.51
BB111	1.55
BB112	1.57
BB115	1.61

PART NO.	WEIGHT (LBS)
BB116	1.62
BB117	1.64
BB118	1.65
BB120	1.68
BB123	1.72
BB124	1.74
BB125	1.75
BB128	1.79
BB129	1.81
BB130	1.82
BB133	1.86
BB136	1.90
BB144	2.02
BB155	2.17
BB158	2.21
BB162	2.27

PART NO.	WEIGHT (LBS)
BB168	2.35
BB169	2.37
BB173	2.42
BB180	2.52
BB182	2.55
BB190	2.66
BB195	2.73
BB210	2.94
BB226	3.16
BB228	3.19
BB230	3.22
BB240	3.36
BB270	3.78
BB277	3.88
BB300	4.20

SAMPLE PART # : CC360

**DOUBLE V-BELTS**

**CC** SECTION : 7/8"W x 5/8"H

PART NO.	WEIGHT (LBS)
CC75	1.73
CC81	1.86
CC85	1.96
CC90	2.07
CC96	2.21
CC105	2.42
CC112	2.58

PART NO.	WEIGHT (LBS)
CC120	2.76
CC128	2.94
CC136	3.13
CC144	3.31
CC158	3.63
CC162	3.73
CC173	3.98

PART NO.	WEIGHT (LBS)
CC180	4.14
CC193	4.44
CC195	4.49
CC204	4.69
CC210	4.83
CC240	5.52

PART NO.	WEIGHT (LBS)
CC270	6.21
CC300	6.9
CC330	7.59
CC360	8.28
CC390	8.97
CC420	9.66

**ADDITIONAL SIZES AVAILABLE. CONTACT CUSTOMER SERVICE FOR DETAILS.**

**Need Help?**

Contact OPTIBELT customer service.  
Our friendly staff is here to assist you.  
TOLL FREE: 800-292-6081  
E-MAIL: [info@optibelt-usa.com](mailto:info@optibelt-usa.com)

**ARAMID CORD DK**

- Special manufactured product.
- Minimum quantities apply.
- Request more information.

Contact an OPTIBELT representative regarding additional sizes, stock availability and pricing.

All weights are estimated.

Additional sizes and stocking available.



# optibelt KK & optibelt RR

## V & ROUND POLYURETHANE BELTS

### KK POLYURETHANE V-BELTS

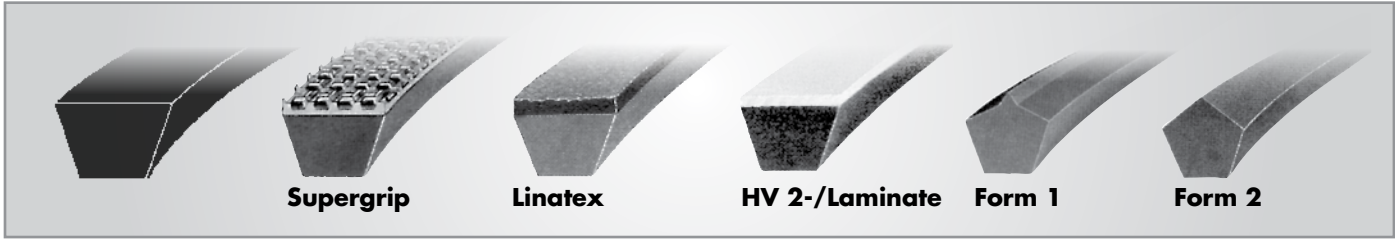

V-BELT SECTION	HEIGHT X WIDTH (IN)	WIDTH X HEIGHT (MM)	ROLL LENGTH (M/FT)	WEIGHT (= KG/M)	SECTION	TRANS 87 SHORE A	WHITE 92 SHORE A	WHITE 98 SHORE A	SUPER GRIP	LINATEX	HV2 LAMINATE	FORM 1	FORM 2
8		5 x 8	50/164	0.041	8		•		N/S	N/S	N/S		
Z/10		10 x 6	50/164	0.055	Z/10	•	•		•	•	N/S		
A/13	1/2 x 11/32	13 x 8	50/164	0.098	A/13	•	•	•	•	•	N/S	N/S	N/S
B/17	21/32 x 7/16	17 x 11	50/164	0.173	B/17	•	•	•	•	•	N/S	N/S	N/S
C/22	7/8 x 9/16	22 x 14	25/ 82	0.275	C/22	•	•		N/S	N/S	N/S	N/S	N/S

CONVEYOR RIDGED-BACK V-BELTS	DIAMETER (MM)	ROLL LENGTH (M/FT)
FORM 1	A/13	25/82
FORM 2	A/13	25/82
FORM 1	B/17	25/82
FORM 2	B/17	25/82
FORM 1	C/22	25/82
FORM 2	C/22	25/82

• Standard Stock, N/S Non-Stocked (min. quantity ordering)

-Orange, 87 Shore A -Red, 92 Shore A -White, 92 Shore A  
-White, 98 Shore A - Supergrip, Green PVC -HV-2 laminate, transparent

KK & RR  
SPECIALTY

### RR POLYURETHANE ROUND

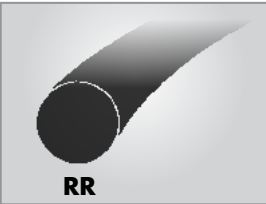

SECTION & DIA. (MM)	ROLL LENGTH M/FT	WEIGHT (= KG/M)	BLACK 65 SHORE A	YELLOW 82 SHORE A	BLUE 85 FDA SHORE A	GREEN SMOOTH 88 SHORE A	GREEN ROUGH 88 SHORE A	WHITE 92 SHORE A	BLUE 98 SHORE A
2 MM	200 M/656 FT	.004		N/S	N/S	•	•	N/S	N/S
3 MM	200 M/656 FT	.009		N/S	N/S	•	•	N/S	N/S
4 MM	200 M/656 FT	.016		N/S	N/S	•	•	N/S	N/S
5 MM	200 M/656 FT	.024		N/S	N/S	•	•	N/S	N/S
6 MM	100 M/328 FT	.035	N/S	N/S	N/S	•	•	N/S	N/S
7 MM	100 M/328 FT	.048	N/S	N/S	N/S	•	•	N/S	N/S
8 MM	100 M/328 FT	.064	N/S	N/S	N/S	•	•	N/S	N/S
10 MM	100 M/328 FT	.096	N/S	N/S	N/S	•	•	N/S	N/S
12 MM	50 M/164 FT	.132	N/S	N/S	N/S	•	•	N/S	N/S
15 MM	50 M/164 FT	.211		N/S	N/S	•	•	N/S	N/S
18 MM	50 M/164 FT	.305				•	•	N/S	N/S

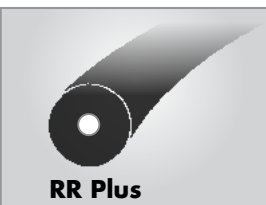

RR PLUS products have tension cords.

SECTION & DIA. (MM)	ROLL LENGTH M/FT	WEIGHT (= KG/M)	BLACK 65 SHORE A	YELLOW 82 SHORE A	BLUE 85 FDA SHORE A	GREEN SMOOTH 88 SHORE A	GREEN ROUGH 88 SHORE A	WHITE 92 SHORE A	BLUE 98 SHORE A
6 MM	100 M/328 FT	.035	N/S	N/S	N/S	N/S	N/S	N/S	N/S
7 MM	100 M/328 FT	.048	N/S	N/S	N/S	N/S	N/S	N/S	N/S
8 MM	100 M/328 FT	.064	N/S	N/S	N/S	N/S	N/S	N/S	N/S
10 MM	100 M/328 FT	.096	N/S	N/S	N/S	N/S	N/S	N/S	N/S
12 MM	50 M/164 FT	.132	N/S	N/S	N/S	N/S	N/S	N/S	N/S
15 MM	50 M/164 FT	.211	N/S	N/S	N/S	N/S	N/S	N/S	N/S

• Standard Stock, N/S Non-Stocked (min. quantity ordering)



**SECTIONS**  
**POLYURETHANE**

**optibelt WR**  
**WIDE ANGLE (60°) V-BELT**



**3M = 3 x 2 mm**  
**5M = 5 x 3 mm**  
**7M = 7 x 5 mm**  
**11M = 11 x 7 mm**



OUTSIDE LENGTH (MM)	3M	5M	7M	11M
180	•			
185	•			
190	•			
195	•			
200	•			
206	•			
212	•			
218	•			
224	•			
230	•			
236	•			
243	•			
250	•			
258	•			
265	•			
272	•			
280	•	•		
290	•	•		
300	•	•		
307	•	•		
315	•	•		
325	•	•		
335	•	•		
345	•	•		
355	•	•		
365	•	•		
375	•	•		
387	•	•		
400	•	•		
412	•	•		

OUTSIDE LENGTH (MM)	3M	5M	7M	11M
425	•	•		
437	•	•		
450	•	•		
462	•	•		
475	•	•		
487	•	•		
500	•	•	•	
515	•	•	•	
530	•	•	•	
545	•	•	•	
560	•	•	•	
580	•	•	•	
600	•	•	•	
615	•	•	•	
630	•	•	•	
650	•	•	•	
670	•	•	•	
690	•	•	•	
710	•	•	•	•
730	•	•	•	•
750	•	•	•	•
775		•	•	•
800		•	•	•
825		•	•	•
850		•	•	•
875		•	•	•
900		•	•	•
925		•	•	•
950		•	•	•
975		•	•	•

OUTSIDE LENGTH (MM)	3M	5M	7M	11M
1000		•	•	•
1030		•	•	•
1060		•	•	•
1090		•	•	•
1120		•	•	•
1150		•	•	•
1180		•	•	•
1220		•	•	•
1250		•	•	•
1280		•	•	•
1320		•	•	•
1360		•	•	•
1400		•	•	•
1450		•	•	•
1500			•	•
1550			•	•
1600			•	•
1650			•	•
1700			•	•
1750			•	•
1800			•	•
1850			•	•
1900			•	•
1950			•	•
2000			•	•
2060			•	•
2120		•	•	•
2180			•	•
2240			•	•
2300			•	•

• Standard Stock

**WR** WIDE ANGLE  
SPECIALTY



**OPTIMAT**  
**OPEN-ENDED V-BELTING, PUNCHED**

This oil and heat resistant open-ended V-Belting can be fitted quickly. Easy to use belt connectors ensure ease of installation.

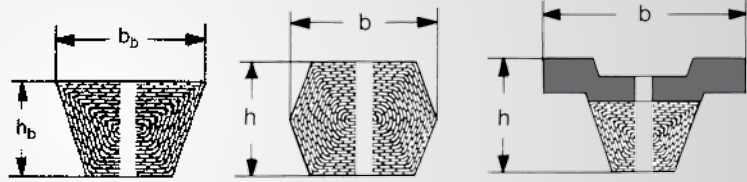

**PROFILES: OE DK FK**

<b>OE SECTIONS</b>	<b>Y/6</b>	<b>8</b>	<b>Z/10</b>	<b>A/13</b>	<b>B/17</b>	<b>20</b>	<b>C/22</b>	<b>25</b>	<b>D/32</b>	<b>E/40</b>
HEIGHT of belt h (mm)	4.0	5.0	6.0	8.0	11.0	12.5	14.0	16.0	20.0	25.0
WIDTH of Belt b (mm)	6.0	8.0	10.0	13.0	17.0	20.0	22.0	25.0	32.0	40.0
WEIGHT (kg/m)	0.03	0.05	0.07	0.12	0.20	0.27	0.34	0.44	0.68	1.00
MAX. FABRICATION LENGTH (in)	1,950	1,950	1,950	1,950	1,950	1,950	1,950	1,950	1,950	1,950
STANDARD GREEN	•	•	•	•	•	•	•	•	•	N/S
POLYESTER RED	•	•	•	•	•	•	•	N/S	N/S	N/S

<b>DK SECTIONS</b>	<b>AA/13</b>	<b>BB/17</b>	<b>CC/22</b>
HEIGHT of belt h (mm)	10.5	14.0	18.0
WIDTH of Belt b (mm)	13.0	17.0	22.0
WEIGHT (kg/m)	0.14	0.25	0.41
MAX. FABRICATION LENGTH (in)	1,950	1,950	1,950
STANDARD GREEN	•	•	•

<b>FK SECTIONS</b>	<b>13X20</b>	<b>17X30</b>	<b>22X40</b>	<b>32X60</b>
HEIGHT of belt h (mm)	16.5	20.0	24.0	33.0
WIDTH of Belt b (mm)	20.0	30.0	40.0	60.0
WEIGHT (kg/m)	0.32	0.46	0.74	1.30
MAX. FABRICATION LENGTH (in)	1,950	1,950	1,950	1,950
STANDARD GREEN	•	•	•	N/S
STANDARD BROWN	•	•	•	N/S
STANDARD WHITE	N/S	N/S	N/S	N/S
POLYESTER BROWN	N/S	N/S	N/S	N/S
POLYESTER WHITE	N/S	N/S	N/S	N/S

• Standard Stock, N/S Non-Stocked (min. quantity ordering)

**OPTIMAT**  
SPECIALTY

**OPTIMAT CONNECTORS**

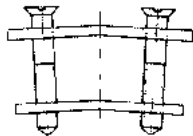

**PLATE CONNECTOR**

Ideal for applications where belt link stiffness is not an issue.



**LINK CONNECTOR**

Ideal for applications where joint stiffness with the connector could cause belt failure.

**Specialized constructions available. Minimum quantities apply.**  
**Contact a Customer Service for more information.**

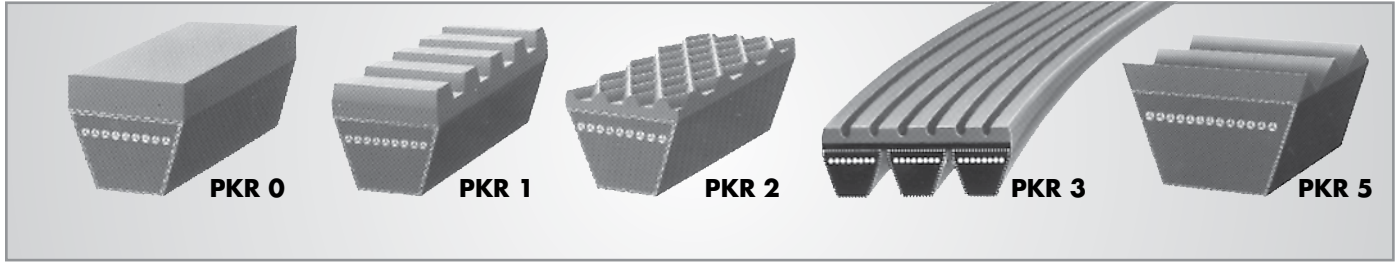

PART NO.	PATTERN HEIGHT		PITCH (MM)	GROOVE WIDTH (IN)
	STD. (IN) / (MM)	MAX. (IN)		
PKR 0	.12 / 3.048	.20 / 5.08	—	—
PKR 1	.12 / 3.048	.20 / 5.08	.40 / 10.16	—
PKR 2	.12 / 3.048	.20 / 5.08	—	—
PKR 3 KRAFTBAND	.20 / 5.08	—	—	.15 / 3.81
PKR 5	.20 / 5.08	—	.51 / 12.954	—

QUALITY / COLOR	TEMPERATURE RESISTANCE (°F)	PITCH (MM)	OIL RESISTANCE	MARKING
SBR-NR/LIGHT COLORED	-40 to +158	55	NO	NO
CR/BLACK	-13 to +212	65	LIMITED	YES

SBR: Styrene Butadiene Rubber NR: Natural Rubber CR: Chloroprene Rubber

ADDITIONAL HEIGHT PATTERNS				3 OR 5 MM ABOVE STANDARD					
SECTION	STD. HGHT (MM)	STANDARD INSIDE LENGTH (MM)		PATTERNS				MIN. ORDER QUANTITIES APPLY	
				PKR 0	PKR 1	PKR 2	PKR 3	STANDARD RANGE (47 to 50)	INTERMEDIATE RANGE
A/13	8	1200	5000 <sup>1</sup>	•	•	•	—	20 PCS., PKR 0 18 PCS.	60 PCS., PKR 0 31 PCS.
B/17	11	1200	7100 <sup>1</sup>	•	•	•	—	15 PCS.	50 PCS.
20	12.5	1850	8000 <sup>2</sup>	•	•	•	—	13 PCS.	21 PCS.
C/22	14	1850	10000 <sup>2</sup>	•	•	•	—	12 PCS.	57 PCS.
25	16	1850	10000 <sup>2</sup>	•	•	•	—	11 PCS.	51 PCS.
D/32	20	2850	12500 <sup>2</sup>	•	•	•	• <sup>3</sup>	9 PCS.	22 PCS.
E/40	25	—	—	—	—	—	—	REQUEST	REQUEST

<sup>1</sup> Maximum production length on request.    <sup>2</sup> Maximum production length 21,000 mm 2/10 on special request.  
<sup>3</sup> Only available in CR/black

STD. HEIGHT PATTERNS			
STANDARD INSIDE LENGTH (MM)	PATTERN TYPE		MIN. QTY.
	PKR 0	PKR 2	
3550 ≤ 10000 <sup>1</sup>	•	•	10
3850 ≤ 21000 <sup>1</sup>	•	•	10
3550 ≤ 21000 <sup>1</sup>	•	•	8
3550 ≤ 21000 <sup>1</sup>	•	•	8
2850 ≤ 21000 <sup>1</sup>	•	•	8
2850 ≤ 21000 <sup>1</sup>	•	•	6
4000 ≤ 21000 <sup>1</sup>	•	•	5

CR/black on request

PKR ENDLESS  
SPECIALTY

When ordering, please state the overall height of the belt including top surface. This is indicated by the section designation as follows:

Section B/17 – top surface within the standard height = 17 x 11  
Section B/17 – with additional 3 mm top surface = 17 x 14  
Section B/17 – with additional 5 mm top surface = 17 x 16

KB KRAFTBANDS WITH PATTERNED TOP SURFACE								
SECTION	BELT DIMENSION W x H (IN)	KRAFTBAND HEIGHT W/O TOP SURFACE (IN) / (MM)	LENGTH (IN)	MAXIMUM PRODUCTION LENGTH (IN)	PATTERNS			
					PKR 0	PKR 1	PKR 2	PKR 3
3V	.35 x .31	.39 / 9.906	50 ≤ 140 L <sub>0</sub>	167	•	—	—	—
5V	.59 x .51	.59 / 14.986	50 ≤ 355 L <sub>0</sub>	394	•	—	—	—
8V	.98 x .91	1 / 25.4	100 ≤ 475 L <sub>0</sub>	590	•	—	—	—
A	.51 x .31	.39 / 9.906	49 ≤ 196 L <sub>1</sub>	394	•	—	—	—
			110 ≤ 394 L <sub>1</sub>	REQUEST MAX.	—	—	—	•
B	.67 x .43	.51 / 12.954	110 ≤ 394 L <sub>1</sub>	394	•	•	•	—
C	.87 x .55	.64 / 16.256	75 ≤ 279 L <sub>1</sub>	394	•	—	—	—

**Additional top surfaces are available. Minimum quantities apply. Contact a Customer Service for more information.**



RB Ribbed Belts are made from OPTIBELT's superior wear-resistant rubber compound blend. The high strength tension cord is engineered for long-lasting performance and quiet operation.



SECTION	H/PH*		J/PJ		K/PK*		L/PL		M/PM	
	INCH	MM	INCH	MM	INCH	MM	INCH	MM	INCH	MM
S	0.063	1.60	0.092	2.34	0.140	3.56	0.185	4.70	0.370	9.40
H	0.10	2.50	0.14	3.50	0.18	4.60	0.28	7.00	0.51	13.00

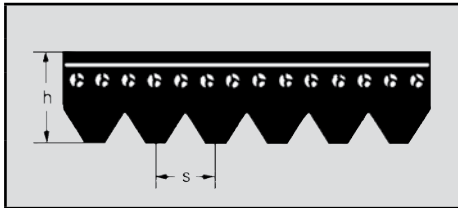

\*H/PH & K/PK section sizes are a non-stocking item. They are available in all standard and non-standard lengths. Contact an OPTIBELT representative for availability and lead times.

J/PJ

**RIBBED BELTS**

SAMPLE PART NO: 354J6

PART NO.	DIN ISO REF. #	WEIGHT (LBS)
110J	PJ 280	0.01
130J	PJ 330	0.01
140J	PJ 356	0.01
143J	PJ 362	0.02
150J	PJ 381	0.02
160J	PJ 406	0.02
163J	PJ 414	0.02
170J	PJ 432	0.02
180J	PJ 457	0.02
190J	PJ 483	0.02
200J	PJ 508	0.02
210J	PJ 533	0.02
220J	PJ 559	0.02
230J	PJ 584	0.02
240J	PJ 610	0.02
260J	PJ 660	0.03
280J	PJ 711	0.03
285J	PJ 723	0.03

PART NO.	DIN ISO REF. #	WEIGHT (LBS)
300J	PJ 762	0.03
320J	PJ 813	0.03
329J	PJ 836	0.03
340J	PJ 864	0.04
360J	PJ 914	0.04
376J	PJ 955	0.04
380J	PJ 965	0.04
400J	PJ 1016	0.04
430J	PJ 1092	0.04
435J	PJ 1105	0.04
437J	PJ 1110	0.04
442J	PJ 1123	0.04
445J	PJ 1130	0.04
453J	PJ 1150	0.05
460J	PJ 1168	0.05
470J	PJ 1194	0.05
473J	PJ 1200	0.05
481J	PJ 1222	0.05

PART NO.	DIN ISO REF. #	WEIGHT (LBS)
490J	PJ 1244	0.05
497J	PJ 1262	0.05
500J	PJ 1270	0.05
506J	PJ 1285	0.05
512J	PJ 1301	0.05
515J	PJ 1312	0.05
518J	PJ 1316	0.05
520J	PJ 1321	0.05
525J	PJ 1333	0.05
534J	PJ 1355	0.05
540J	PJ 1371	0.06
550J	PJ 1397	0.06
562J	PJ 1428	0.06
567J	PJ 1439	0.06
580J	PJ 1473	0.06
581J	PJ 1475	0.06
610J	PJ 1549	0.06
630J	PJ 1600	0.06

PART NO.	DIN ISO REF. #	WEIGHT (LBS)
650J	PJ 1651	0.07
655J	PJ 1663	0.07
690J	PJ 1752	0.07
700J	PJ 1780	0.07
730J	PJ 1854	0.07
746J	PJ 1895	0.07
752J	PJ 1910	0.07
754J	PJ 1915	0.07
760J	PJ 1930	0.08
770J	PJ 1956	0.08
774J	PJ 1965	0.08
780J	PJ 1981	0.08
784J	PJ 1992	0.08
820J	PJ 2083	0.08
848J	PJ 2155	0.09
870J	PJ 2210	0.09
920J	PJ 2337	0.09
980J	PJ 2489	0.10

**LENGTHS:** 220J = 22 in. external length, PJ 559 = 559 mm external length

RB RIBBED BELTS

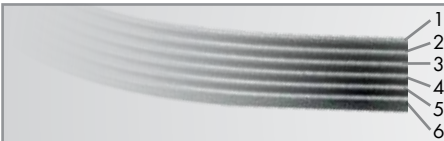

**DETERMINING BELT WIDTH**

If you are not sure simply count the number of the ridges, or "ribs", on the belt.

**EXAMPLE PART NUMBERS:**

- 180J4 (4 RIBS, J or PJ 457)
- 490J10 (10 RIBS, J or PJ 1244)
- 470J6 (6 RIBS, J or PJ 1194)
- 870J8 (8 RIBS, J or PJ 2210)

**EXPEDITED SHIPPING:**

Each OPTIBELT warehouse facility cuts Ribbed belts to width to expedited customer orders.

Contact an OPTIBELT representative regarding additional sizes, stock availability and pricing.

All weights are estimated.

**Additional Sizes & Ordering**

Additional stocked and custom sizes available.

Contact customer service for details.

**\*H/PH & K/PK**

section sizes are a non-stocking item.

Contact an OPTIBELT representative for availability.



SAMPLE PART NO: 930L4

**RIBBED BELTS**

L/PL

PART NO.	DIN ISO REF. #	WEIGHT (LBS)
500L	PL 1270	0.80
540L	PL 1371	0.86
560L	PL 1422	0.90
615L	PL 1562	0.99
655L	PL 1664	1.05
675L	PL 1715	1.08
695L	PL 1764	1.11
725L	PL 1841	1.16
765L	PL 1943	1.23

PART NO.	DIN ISO REF. #	WEIGHT (LBS)
780L	PL 1981	1.25
795L	PL 2020	1.28
815L	PL 2070	1.31
840L	PL 2134	1.35
865L	PL 2197	1.39
915L	PL 2324	1.47
930L	PL 2362	1.49
975L	PL 2476	1.56
990L	PL 2515	1.59

PART NO.	DIN ISO REF. #	WEIGHT (LBS)
1065L	PL 2705	1.71
1080L	PL 2743	1.73
1140L	PL 2895	1.83
1150L	PL 2921	1.84
1180L	PL 2997	1.89
1215L	PL 3086	1.95
1230L	PL 3124	1.97
1295L	PL 3289	2.08
1310L	PL 3327	2.10

PART NO.	DIN ISO REF. #	WEIGHT (LBS)
1455L	PL 3696	2.33
1595L	PL 4051	2.55
1650L	PL 4191	2.64
1760L	PL 4470	2.82
1820L	PL 4622	2.92
1980L	PL 5092	3.17
2120L	PL 5385	3.39
2400L	PL 6096	3.84

**LENGTHS:** 865L = 86.5 in. external length, PL 2197 = 2197 mm external length

SAMPLE PART NO: 2560M4

**RIBBED BELTS**

M/PM

PART NO.	DIN ISO REF. #	WEIGHT (LBS)
900M	PM 2286	1.15
940M	PM 2388	1.20
990M	PM 2515	1.26
1060M	PM 2693	1.35
1115M	PM 2832	1.42
1150M	PM 2921	1.47
1185M	PM 3010	1.51

PART NO.	DIN ISO REF. #	WEIGHT (LBS)
1230M	PM 3124	1.57
1310M	PM 3327	1.67
1390M	PM 3531	1.77
1470M	PM 3734	1.87
1610M	PM 4089	2.05
1650M	PM 4191	2.10
1760M	PM 4470	2.24

PART NO.	DIN ISO REF. #	WEIGHT (LBS)
1830M	PM 4648	2.33
1980M	PM 5029	2.52
2130M	PM 5410	2.71
2410M	PM 6121	3.07
2560M	PM 6502	3.26
2710M	PM 6883	3.45
3010M	PM 7646	3.83

PART NO.	DIN ISO REF. #	WEIGHT (LBS)
3310M	PM 8408	4.22
3910M	PM 9931	4.98
4210M	PM 10693	5.36
4810M	PM 12217	6.13

**LENGTHS:** 1980M = 86.5 in. external length, PL 5029 = 5029 mm external length

**EXAMPLE PART NUMBERS:**

- 500L4 (4 RIBS, L or PL 1270)
- 840L6 (6 RIBS, L or PL 1194)
- 1230L8 (8 RIBS, L or PL 3124)
- 1830M10 (10 RIBS, M or PM 2921)

**EXPEDITED SHIPPING:**

Each OPTIBELT warehouse facility cuts Ribbed belts to width to expedited customer orders.

RIBBED BELTS RB

**ELASTIC RIBBED BELTS**

**SECTIONS: EPH, EPJ**

The superstructure is made from a fiber-reinforced rubber mixture. The fibers are laid perpendicular to the direction of belt travel and stabilize the belt during dynamic operation. The tension cord is a high modulus polyamide material embedded in a rubber compound and covers the entire width of the ribbed belt. The rib compound is characterized by a high wear resistance.

Elastic ribbed belts sections EPH and EPJ consist of a:

- superstructure
- elastic tension cord section
- base

**\*H/PH & K/PK**

section sizes are a non-stocking item.  
Contact an OPTIBELT representative for availability.

**Additional Sizes & Ordering**

Additional stocked and custom sizes available.  
Contact customer service for details.

Contact an OPTIBELT representative regarding additional sizes, stock availability and pricing.

All weights are estimated.



OMEGA HL is an ultra-high performance belt engineered to perform under extreme loads and a complete range of speeds.

- **Industrial Performance:** Reinforced fiberglass cords provide incredible strength and pulling force.
- **Low-Noise:** OMEGA tooth design and fabric cover for quieter operation.
- **Durability:** Reinforced fabric cover provides for increased wear resistance.
- **Strength:** Aramid fibers are blended into the rubber compound for a tooth structure with incredible shear strength and low friction.
- **Versatility:** Fits HTD and RPP Pulleys
- **Temperature Range:** Increased operation range -22 to 212°F
- **Anti-static:** Meets ISO 9563 requirements for being anti-static.



**8M SECTION 8 MM PITCH**

**OMEGA HL TIMING**

SAMPLE PART # : 840-8MHL-30

PART NUMBER	PITCH LENGTH (MM)	NO. OF TEETH	PART NUMBER	PITCH LENGTH (MM)	NO. OF TEETH	PART NUMBER	PITCH LENGTH (MM)	NO. OF TEETH	PART NUMBER	PITCH LENGTH (MM)	NO. OF TEETH
288-8MHL-20	288	36	784-8MHL-20	784	98	1120-8MHL-20	1120	140	1584-8MHL-20	1584	198
352-8MHL-20	352	44	800-8MHL-20	800	100	1128-8MHL-20	1128	141	1600-8MHL-20	1600	200
376-8MHL-20	376	47	824-8MHL-20	824	103	1160-8MHL-20	1160	145	1680-8MHL-20	1680	210
416-8MHL-20	416	52	840-8MHL-20	840	105	1184-8MHL-20	1184	148	1696-8MHL-20	1696	212
424-8MHL-20	424	53	848-8MHL-20	848	106	1200-8MHL-20	1200	150	1728-8MHL-20	1728	216
480-8MHL-20	480	60	856-8MHL-20	856	107	1216-8MHL-20	1216	152	1760-8MHL-20	1760	220
560-8MHL-20	560	70	880-8MHL-20	880	110	1224-8MHL-20	1224	153	1800-8MHL-20	1800	225
576-8MHL-20	576	72	896-8MHL-20	896	112	1248-8MHL-20	1248	156	1936-8MHL-20	1936	242
600-8MHL-20	600	75	912-8MHL-20	912	114	1280-8MHL-20	1280	160	2000-8MHL-20	2000	250
608-8MHL-20	608	76	920-8MHL-20	920	115	1304-8MHL-20	1304	163	2240-8MHL-20	2240	280
632-8MHL-20	632	79	960-8MHL-20	960	120	1344-8MHL-20	1344	168	2248-8MHL-20	2248	281
640-8MHL-20	640	80	976-8MHL-20	976	122	1360-8MHL-20	1360	170	2272-8MHL-20	2272	284
656-8MHL-20	656	82	1000-8MHL-20	1000	125	1400-8MHL-20	1400	175	2400-8MHL-20	2400	300
680-8MHL-20	680	85	1040-8MHL-20	1040	130	1424-8MHL-20	1424	178	2504-8MHL-20	2504	313
712-8MHL-20	712	89	1056-8MHL-20	1056	132	1440-8MHL-20	1440	180	2600-8MHL-20	2600	325
720-8MHL-20	720	90	1064-8MHL-20	1064	133	1520-8MHL-20	1520	190	2800-8MHL-20	2800	350
760-8MHL-20	760	95	1080-8MHL-20	1080	135	1552-8MHL-20	1552	194	3280-8MHL-20	3280	410
776-8MHL-20	776	97	1096-8MHL-20	1096	137						
288-8MHL-30	288	36	632-8MHL-30	632	79	824-8MHL-30	824	103	1000-8MHL-30	1000	125
352-8MHL-30	352	44	640-8MHL-30	640	80	840-8MHL-30	840	105	1040-8MHL-30	1040	130
376-8MHL-30	376	47	656-8MHL-30	656	82	848-8MHL-30	848	106	1056-8MHL-30	1056	132
416-8MHL-30	416	52	680-8MHL-30	680	85	856-8MHL-30	856	107	1064-8MHL-30	1064	133
424-8MHL-30	424	53	712-8MHL-30	712	89	880-8MHL-30	880	110	1080-8MHL-30	1080	135
480-8MHL-30	480	60	720-8MHL-30	720	90	896-8MHL-30	896	112	1096-8MHL-30	1096	137
560-8MHL-30	560	70	760-8MHL-30	760	95	912-8MHL-30	912	114	1120-8MHL-30	1120	140
576-8MHL-30	576	72	776-8MHL-30	776	97	920-8MHL-30	920	115	1128-8MHL-30	1128	141
600-8MHL-30	600	75	784-8MHL-30	784	98	960-8MHL-30	960	120			
608-8MHL-30	608	76	800-8MHL-30	800	100	976-8MHL-30	976	122			

HL 8M  
OMEGA TIMING

Contact an OPTIBELT representative regarding additional sizes, stock availability and pricing.

**EXPEDITED SHIPPING:** Each OPTIBELT warehouse facility cuts timing belts to width for faster order service.

**EXAMPLE SIZING:**

Part Number: 1800-8MHL-20 (HL=BELT CONSTRUCTION)

1800 = 1800 mm Pitch Length 8M = Section & Construction 20 = 20 mm Belt Width

Part Number: 712-8MHL-30 (HL=BELT CONSTRUCTION)

712 = 712 mm Pitch Length 8M = Section & Construction 30 = 30 mm Belt Width



SAMPLE PART # : 1304-8MHL-50

**OMEGA HL TIMING**

8M SECTION 8 MM PITCH

PART NUMBER	PITCH LENGTH (MM)	NO. OF TEETH	PART NUMBER	PITCH LENGTH (MM)	NO. OF TEETH	PART NUMBER	PITCH LENGTH (MM)	NO. OF TEETH	PART NUMBER	PITCH LENGTH (MM)	NO. OF TEETH
1160-8MHL-30	1160	145	1344-8MHL-30	1344	168	1600-8MHL-30	1600	200	2240-8MHL-30	2240	280
1184-8MHL-30	1184	148	1360-8MHL-30	1360	170	1680-8MHL-30	1680	210	2248-8MHL-30	2248	281
1200-8MHL-30	1200	150	1400-8MHL-30	1400	175	1696-8MHL-30	1696	212	2272-8MHL-30	2272	284
1216-8MHL-30	1216	152	1424-8MHL-30	1424	178	1728-8MHL-30	1728	216	2400-8MHL-30	2400	300
1224-8MHL-30	1224	153	1440-8MHL-30	1440	180	1760-8MHL-30	1760	220	2504-8MHL-30	2504	313
1248-8MHL-30	1248	156	1520-8MHL-30	1520	190	1800-8MHL-30	1800	225	2600-8MHL-30	2600	325
1280-8MHL-30	1280	160	1552-8MHL-30	1552	194	1936-8MHL-30	1936	242	2800-8MHL-30	2800	350
1304-8MHL-30	1304	163	1584-8MHL-30	1584	198	2000-8MHL-30	2000	250	3280-8MHL-30	3280	410
288-8MHL-50	288	36	784-8MHL-50	784	98	1120-8MHL-50	1120	140	1584-8MHL-50	1584	198
352-8MHL-50	352	44	800-8MHL-50	800	100	1128-8MHL-50	1128	141	1600-8MHL-50	1600	200
376-8MHL-50	376	47	824-8MHL-50	824	103	1160-8MHL-50	1160	145	1680-8MHL-50	1680	210
416-8MHL-50	416	52	840-8MHL-50	840	105	1184-8MHL-50	1184	148	1696-8MHL-50	1696	212
424-8MHL-50	424	53	848-8MHL-50	848	106	1200-8MHL-50	1200	150	1728-8MHL-50	1728	216
480-8MHL-50	480	60	856-8MHL-50	856	107	1216-8MHL-50	1216	152	1760-8MHL-50	1760	220
560-8MHL-50	560	70	880-8MHL-50	880	110	1224-8MHL-50	1224	153	1800-8MHL-50	1800	225
576-8MHL-50	576	72	896-8MHL-50	896	112	1248-8MHL-50	1248	156	1936-8MHL-50	1936	242
600-8MHL-50	600	75	912-8MHL-50	912	114	1280-8MHL-50	1280	160	2000-8MHL-50	2000	250
608-8MHL-50	608	76	920-8MHL-50	920	115	1304-8MHL-50	1304	163	2240-8MHL-50	2240	280
632-8MHL-50	632	79	960-8MHL-50	960	120	1344-8MHL-50	1344	168	2248-8MHL-50	2248	281
640-8MHL-50	640	80	976-8MHL-50	976	122	1360-8MHL-50	1360	170	2272-8MHL-50	2272	284
656-8MHL-50	656	82	1000-8MHL-50	1000	125	1400-8MHL-50	1400	175	2400-8MHL-50	2400	300
680-8MHL-50	680	85	1040-8MHL-50	1040	130	1424-8MHL-50	1424	178	2504-8MHL-50	2504	313
712-8MHL-50	712	89	1056-8MHL-50	1056	132	1440-8MHL-50	1440	180	2600-8MHL-50	2600	325
720-8MHL-50	720	90	1064-8MHL-50	1064	133	1520-8MHL-50	1520	190	2800-8MHL-50	2800	350
760-8MHL-50	760	95	1080-8MHL-50	1080	135	1552-8MHL-50	1552	194	3280-8MHL-50	3280	410
776-8MHL-50	776	97	1096-8MHL-50	1096	137						
288-8MHL-85	288	36	680-8MHL-85	680	85	912-8MHL-85	912	114	1184-8MHL-85	1184	148
352-8MHL-85	352	44	712-8MHL-85	712	89	920-8MHL-85	920	115	1200-8MHL-85	1200	150
376-8MHL-85	376	47	720-8MHL-85	720	90	960-8MHL-85	960	120	1216-8MHL-85	1216	152
416-8MHL-85	416	52	760-8MHL-85	760	95	976-8MHL-85	976	122	1224-8MHL-85	1224	153
424-8MHL-85	424	53	776-8MHL-85	776	97	1000-8MHL-85	1000	125	1248-8MHL-85	1248	156
480-8MHL-85	480	60	784-8MHL-85	784	98	1040-8MHL-85	1040	130	1280-8MHL-85	1280	160
560-8MHL-85	560	70	800-8MHL-85	800	100	1056-8MHL-85	1056	132	1304-8MHL-85	1304	163
576-8MHL-85	576	72	824-8MHL-85	824	103	1064-8MHL-85	1064	133	1344-8MHL-85	1344	168
600-8MHL-85	600	75	840-8MHL-85	840	105	1080-8MHL-85	1080	135	1360-8MHL-85	1360	170
608-8MHL-85	608	76	848-8MHL-85	848	106	1096-8MHL-85	1096	137	1400-8MHL-85	1400	175
632-8MHL-85	632	79	856-8MHL-85	856	107	1120-8MHL-85	1120	140	1424-8MHL-85	1424	178
640-8MHL-85	640	80	880-8MHL-85	880	110	1128-8MHL-85	1128	141			
656-8MHL-85	656	82	896-8MHL-85	896	112	1160-8MHL-85	1160	145			

**8M CONTINUED PG 54**

OMEGA TIMING  
**HL 8M**

**EXAMPLE SIZING:**  
Part Number: 1280-8MHL-50 (HL=BELT CONSTRUCTION)  
1280 = 1280 mm Pitch Length 8M = Section & Construction 50 = 50 mm Belt Width  
Part Number: 600-8MHL-85 (HL=BELT CONSTRUCTION)  
600 = 600 mm Pitch Length 8M = Section & Construction 85 = 85 mm Belt Width

Contact an OPTIBELT representative regarding additional sizes, stock availability and pricing.  
**EXPEDITED SHIPPING:** Each OPTIBELT warehouse facility cuts timing belts to width for faster order service.



**8M SECTION 8 MM PITCH**

**OMEGA HL TIMING**

SAMPLE PART # : 1552-8MHL-85

PART NUMBER	PITCH LENGTH (MM)	NO. OF TEETH	PART NUMBER	PITCH LENGTH (MM)	NO. OF TEETH	PART NUMBER	PITCH LENGTH (MM)	NO. OF TEETH	PART NUMBER	PITCH LENGTH (MM)	NO. OF TEETH
1440-8MHL-85	1440	180	1680-8MHL-85	1680	210	1936-8MHL-85	1936	242	2400-8MHL-85	2400	300
1520-8MHL-85	1520	190	1696-8MHL-85	1696	212	2000-8MHL-85	2000	250	2504-8MHL-85	2504	313
1552-8MHL-85	1552	194	1728-8MHL-85	1728	216	2240-8MHL-85	2240	280	2600-8MHL-85	2600	325
1584-8MHL-85	1584	198	1760-8MHL-85	1760	220	2248-8MHL-85	2248	281	2800-8MHL-85	2800	350
1600-8MHL-85	1600	200	1800-8MHL-85	1800	225	2272-8MHL-85	2272	284	3280-8MHL-85	3280	410

**14M SECTION 14 MM PITCH**

**OMEGA HL TIMING**

SAMPLE PART # : 3360-14MHL-85

PART NUMBER	PITCH LENGTH (MM)	NO. OF TEETH	PART NUMBER	PITCH LENGTH (MM)	NO. OF TEETH	PART NUMBER	PITCH LENGTH (MM)	NO. OF TEETH	PART NUMBER	PITCH LENGTH (MM)	NO. OF TEETH
966-14MHL-40	966	69	1610-14MHL-40	1610	115	2450-14MHL-40	2450	175	3500-14MHL-40	3500	250
1092-14MHL-40	1092	78	1778-14MHL-40	1778	127	2590-14MHL-40	2590	185	3850-14MHL-40	3850	275
1190-14MHL-40	1190	85	1890-14MHL-40	1890	135	2800-14MHL-40	2800	200	4326-14MHL-40	4326	309
1400-14MHL-40	1400	100	2100-14MHL-40	2100	150	3150-14MHL-40	3150	225	4578-14MHL-40	4578	327
1456-14MHL-40	1456	104	2310-14MHL-40	2310	165	3360-14MHL-40	3360	240			
966-14MHL-55	966	69	1610-14MHL-55	1610	115	2450-14MHL-55	2450	175	3500-14MHL-55	3500	250
1092-14MHL-55	1092	78	1778-14MHL-55	1778	127	2590-14MHL-55	2590	185	3850-14MHL-55	3850	275
1190-14MHL-55	1190	85	1890-14MHL-55	1890	135	2800-14MHL-55	2800	200	4326-14MHL-55	4326	309
1400-14MHL-55	1400	100	2100-14MHL-55	2100	150	3150-14MHL-55	3150	225	4578-14MHL-55	4578	327
1456-14MHL-55	1456	104	2310-14MHL-55	2310	165	3360-14MHL-55	3360	240			
966-14MHL-85	966	69	1610-14MHL-85	1610	115	2450-14MHL-85	2450	175	3500-14MHL-85	3500	250
1092-14MHL-85	1092	78	1778-14MHL-85	1778	127	2590-14MHL-85	2590	185	3850-14MHL-85	3850	275
1190-14MHL-85	1190	85	1890-14MHL-85	1890	135	2800-14MHL-85	2800	200	4326-14MHL-85	4326	309
1400-14MHL-85	1400	100	2100-14MHL-85	2100	150	3150-14MHL-85	3150	225	4578-14MHL-85	4578	327
1456-14MHL-85	1456	104	2310-14MHL-85	2310	165	3360-14MHL-85	3360	240			
966-14MHL-115	966	69	1610-14MHL-115	1610	115	2450-14MHL-115	2450	175	3500-14MHL-115	3500	250
1092-14MHL-115	1092	78	1778-14MHL-115	1778	127	2590-14MHL-115	2590	185	3850-14MHL-115	3850	275
1190-14MHL-115	1190	85	1890-14MHL-115	1890	135	2800-14MHL-115	2800	200	4326-14MHL-115	4326	309
1400-14MHL-115	1400	100	2100-14MHL-115	2100	150	3150-14MHL-115	3150	225	4578-14MHL-115	4578	327
1456-14MHL-115	1456	104	2310-14MHL-115	2310	165	3360-14MHL-115	3360	240			
966-14MHL-170	966	69	1610-14MHL-170	1610	115	2450-14MHL-170	2450	175	3500-14MHL-170	3500	250
1092-14MHL-170	1092	78	1778-14MHL-170	1778	127	2590-14MHL-170	2590	185	3850-14MHL-170	3850	275
1190-14MHL-170	1190	85	1890-14MHL-170	1890	135	2800-14MHL-170	2800	200	4326-14MHL-170	4326	309
1400-14MHL-170	1400	100	2100-14MHL-170	2100	150	3150-14MHL-170	3150	225	4578-14MHL-170	4578	327
1456-14MHL-170	1456	104	2310-14MHL-170	2310	165	3360-14MHL-170	3360	240			

HL 14/8M  
OMEGA TIMING

Contact an OPTIBELT representative regarding additional sizes, stock availability and pricing.

**EXPEDITED SHIPPING:** Each OPTIBELT warehouse facility cuts timing belts to width for faster order service.

**EXAMPLE SIZING:**

Part Number: 1610-14MHL-85 (HL=BELT CONSTRUCTION)  
1610 = 1610 mm Pitch Length    14M = Section & Construction    85 = 85 mm Belt Width  
 Part Number: 3850-14MHL-170 (HL=BELT CONSTRUCTION)  
3850 = 3850 mm Pitch Length    14M = Section & Construction    170 = 170 mm Belt Width





OMEGA HP high performance belts were developed for high speed drives. With its superior construction OMEGA HP belts have the durability and performance characteristics far superior than standard timing belts.

- **High Performance:** Fiberglass cords provide incredible strength and pulling force.
- **Low-Noise:** OMEGA tooth design and fabric cover for quieter operation.
- **Durability:** Reinforced fabric cover provides for increased wear resistance.
- **Strength:** Aramid fibers are blended into the rubber compound for a tooth structure with incredible shear strength and low friction.
- **Versatility:** Fits HTD and RPP Pulleys
- **Temperature Range:** Increased operation range -22 to 212°F
- **Anti-static:** Meets ISO 9563 requirements for being anti-static.

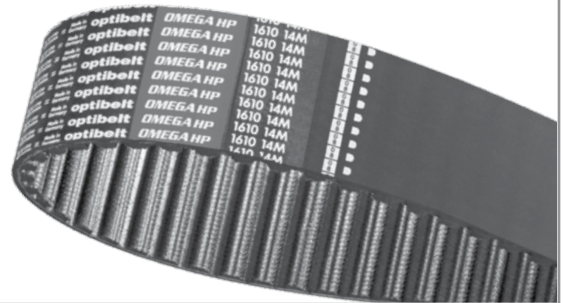

SAMPLE PART # : 675-3MHP-6

**OMEGA HP TIMING**

3M SECTION 3 MM PITCH

PART NUMBER	PITCH LENGTH (MM)	NO. OF TEETH	PART NUMBER	PITCH LENGTH (MM)	NO. OF TEETH	PART NUMBER	PITCH LENGTH (MM)	NO. OF TEETH	PART NUMBER	PITCH LENGTH (MM)	NO. OF TEETH
111-3MHP-6	111	37	225-3MHP-6	225	75	357-3MHP-6	357	119	558-3MHP-6	558	186
129-3MHP-6	129	43	240-3MHP-6	240	80	363-3MHP-6	363	121	564-3MHP-6	564	188
141-3MHP-6	141	47	246-3MHP-6	246	82	366-3MHP-6	366	122	570-3MHP-6	570	190
144-3MHP-6	144	48	249-3MHP-6	249	83	384-3MHP-6	384	128	582-3MHP-6	582	194
150-3MHP-6	150	50	252-3MHP-6	252	84	390-3MHP-6	390	130	597-3MHP-6	597	199
159-3MHP-6	159	53	255-3MHP-6	255	85	420-3MHP-6	420	140	600-3MHP-6	600	200
165-3MHP-6	165	55	267-3MHP-6	267	89	426-3MHP-6	426	142	606-3MHP-6	606	202
168-3MHP-6	168	56	276-3MHP-6	276	92	435-3MHP-6	435	145	615-3MHP-6	615	205
171-3MHP-6	171	57	282-3MHP-6	282	94	447-3MHP-6	447	149	633-3MHP-6	633	211
174-3MHP-6	174	58	285-3MHP-6	285	95	462-3MHP-6	462	154	669-3MHP-6	669	223
177-3MHP-6	177	59	288-3MHP-6	288	96	474-3MHP-6	474	158	675-3MHP-6	675	225
180-3MHP-6	180	60	291-3MHP-6	291	97	480-3MHP-6	480	160	711-3MHP-6	711	237
183-3MHP-6	183	61	294-3MHP-6	294	98	486-3MHP-6	486	162	738-3MHP-6	738	246
186-3MHP-6	186	62	300-3MHP-6	300	100	495-3MHP-6	495	165	804-3MHP-6	804	268
192-3MHP-6	192	64	312-3MHP-6	312	104	501-3MHP-6	501	167	816-3MHP-6	816	272
195-3MHP-6	195	65	315-3MHP-6	315	105	513-3MHP-6	513	171	843-3MHP-6	843	281
201-3MHP-6	201	67	318-3MHP-6	318	106	519-3MHP-6	519	173	882-3MHP-6	882	294
204-3MHP-6	204	68	330-3MHP-6	330	110	522-3MHP-6	522	174	888-3MHP-6	888	296
207-3MHP-6	207	69	333-3MHP-6	333	111	525-3MHP-6	525	175	1062-3MHP-6	1062	354
210-3MHP-6	210	70	339-3MHP-6	339	113	531-3MHP-6	531	177	1569-3MHP-6	1569	523
213-3MHP-6	213	71	345-3MHP-6	345	115	537-3MHP-6	537	179	1692-3MHP-6	1692	564
111-3MHP-9	111	37	168-3MHP-9	168	56	192-3MHP-9	192	64	225-3MHP-9	225	75
129-3MHP-9	129	43	171-3MHP-9	171	57	195-3MHP-9	195	65	240-3MHP-9	240	80
141-3MHP-9	141	47	174-3MHP-9	174	58	201-3MHP-9	201	67	246-3MHP-9	246	82
144-3MHP-9	144	48	177-3MHP-9	177	59	204-3MHP-9	204	68	249-3MHP-9	249	83
150-3MHP-9	150	50	180-3MHP-9	180	60	207-3MHP-9	207	69	252-3MHP-9	252	84
159-3MHP-9	159	53	183-3MHP-9	183	61	210-3MHP-9	210	70			
165-3MHP-9	165	55	186-3MHP-9	186	62	213-3MHP-9	213	71			

3M CONTINUED PG 56

HP 3M  
OMEGA TIMING

**EXAMPLE SIZING:**

Part Number: 180-3MHP-6 (HP=BELT CONSTRUCTION)  
 180 = 180 mm Pitch Length 3M = Section & Construction  $\phi$  = 6 mm Belt Width  
 Part Number: 240-3MHP-9 (HP=BELT CONSTRUCTION)  
 240 = 240 mm Pitch Length 3M = Section & Construction  $\phi$  = 9 mm Belt Width

Contact an OPTIBELT representative regarding additional sizes, stock availability and pricing.

**EXPEDITED SHIPPING:** Each OPTIBELT warehouse facility cuts timing belts to width for faster order service.



3M SECTION 3 MM PITCH

**OMEGA HP TIMING**

SAMPLE PART # : 669-3MHP-15

PART NUMBER	PITCH LENGTH (MM)	NO. OF TEETH	PART NUMBER	PITCH LENGTH (MM)	NO. OF TEETH	PART NUMBER	PITCH LENGTH (MM)	NO. OF TEETH	PART NUMBER	PITCH LENGTH (MM)	NO. OF TEETH
255-3MHP-9	255	85	345-3MHP-9	345	115	501-3MHP-9	501	167	615-3MHP-9	615	205
267-3MHP-9	267	89	357-3MHP-9	357	119	513-3MHP-9	513	171	633-3MHP-9	633	211
276-3MHP-9	276	92	363-3MHP-9	363	121	519-3MHP-9	519	173	669-3MHP-9	669	223
282-3MHP-9	282	94	366-3MHP-9	366	122	522-3MHP-9	522	174	675-3MHP-9	675	225
285-3MHP-9	285	95	384-3MHP-9	384	128	525-3MHP-9	525	175	711-3MHP-9	711	237
288-3MHP-9	288	96	390-3MHP-9	390	130	531-3MHP-9	531	177	738-3MHP-9	738	246
291-3MHP-9	291	97	420-3MHP-9	420	140	537-3MHP-9	537	179	804-3MHP-9	804	268
294-3MHP-9	294	98	426-3MHP-9	426	142	558-3MHP-9	558	186	816-3MHP-9	816	272
300-3MHP-9	300	100	435-3MHP-9	435	145	564-3MHP-9	564	188	843-3MHP-9	843	281
312-3MHP-9	312	104	447-3MHP-9	447	149	570-3MHP-9	570	190	882-3MHP-9	882	294
315-3MHP-9	315	105	462-3MHP-9	462	154	582-3MHP-9	582	194	888-3MHP-9	888	296
318-3MHP-9	318	106	474-3MHP-9	474	158	597-3MHP-9	597	199	1062-3MHP-9	1062	354
330-3MHP-9	330	110	480-3MHP-9	480	160	600-3MHP-9	600	200	1569-3MHP-9	1569	523
333-3MHP-9	333	111	486-3MHP-9	486	162	606-3MHP-9	606	202	1692-3MHP-9	1692	564
339-3MHP-9	339	113	495-3MHP-9	495	165						
111-3MHP-15	111	37	225-3MHP-15	225	75	357-3MHP-15	357	119	558-3MHP-15	558	186
129-3MHP-15	129	43	240-3MHP-15	240	80	363-3MHP-15	363	121	564-3MHP-15	564	188
141-3MHP-15	141	47	246-3MHP-15	246	82	366-3MHP-15	366	122	570-3MHP-15	570	190
144-3MHP-15	144	48	249-3MHP-15	249	83	384-3MHP-15	384	128	582-3MHP-15	582	194
150-3MHP-15	150	50	252-3MHP-15	252	84	390-3MHP-15	390	130	597-3MHP-15	597	199
159-3MHP-15	159	53	255-3MHP-15	255	85	420-3MHP-15	420	140	600-3MHP-15	600	200
165-3MHP-15	165	55	267-3MHP-15	267	89	426-3MHP-15	426	142	606-3MHP-15	606	202
168-3MHP-15	168	56	276-3MHP-15	276	92	435-3MHP-15	435	145	615-3MHP-15	615	205
171-3MHP-15	171	57	282-3MHP-15	282	94	447-3MHP-15	447	149	633-3MHP-15	633	211
174-3MHP-15	174	58	285-3MHP-15	285	95	462-3MHP-15	462	154	669-3MHP-15	669	223
177-3MHP-15	177	59	288-3MHP-15	288	96	474-3MHP-15	474	158	675-3MHP-15	675	225
180-3MHP-15	180	60	291-3MHP-15	291	97	480-3MHP-15	480	160	711-3MHP-15	711	237
183-3MHP-15	183	61	294-3MHP-15	294	98	486-3MHP-15	486	162	738-3MHP-15	738	246
186-3MHP-15	186	62	300-3MHP-15	300	100	495-3MHP-15	495	165	804-3MHP-15	804	268
192-3MHP-15	192	64	312-3MHP-15	312	104	501-3MHP-15	501	167	816-3MHP-15	816	272
195-3MHP-15	195	65	315-3MHP-15	315	105	513-3MHP-15	513	171	843-3MHP-15	843	281
201-3MHP-15	201	67	318-3MHP-15	318	106	519-3MHP-15	519	173	882-3MHP-15	882	294
204-3MHP-15	204	68	330-3MHP-15	330	110	522-3MHP-15	522	174	888-3MHP-15	888	296
207-3MHP-15	207	69	333-3MHP-15	333	111	525-3MHP-15	525	175	1062-3MHP-15	1062	354
210-3MHP-15	210	70	339-3MHP-15	339	113	531-3MHP-15	531	177	1569-3MHP-15	1569	523
213-3MHP-15	213	71	345-3MHP-15	345	115	537-3MHP-15	537	179	1692-3MHP-15	1692	564

HP 3M  
OMEGA TIMING

Contact an OPTIBELT representative regarding additional sizes, stock availability and pricing.

**EXPEDITED SHIPPING:** Each OPTIBELT warehouse facility cuts timing belts to width for faster order service.

**EXAMPLE SIZING:**

Part Number: 318-3MHP-9 (HP=BELT CONSTRUCTION)  
318 = 318 mm Pitch Length    3M = Section & Construction    9 = 9 mm Belt Width  
 Part Number: 435-3MHP-15 (HP=BELT CONSTRUCTION)  
435 = 435 mm Pitch Length    3M = Section & Construction    15 = 15 mm Belt Width



SAMPLE PART # : 535-5MHP-9

**OMEGA HP TIMING**

**5M** SECTION 5 MM PITCH

PART NUMBER	PITCH LENGTH (MM)	NO. OF TEETH	PART NUMBER	PITCH LENGTH (MM)	NO. OF TEETH	PART NUMBER	PITCH LENGTH (MM)	NO. OF TEETH	PART NUMBER	PITCH LENGTH (MM)	NO. OF TEETH
180-5MHP-9	180	36	460-5MHP-9	460	92	700-5MHP-9	700	140	1000-5MHP-9	1000	200
225-5MHP-9	225	45	475-5MHP-9	475	95	710-5MHP-9	710	142	1025-5MHP-9	1025	205
255-5MHP-9	255	51	490-5MHP-9	490	98	720-5MHP-9	720	144	1035-5MHP-9	1035	207
265-5MHP-9	265	53	500-5MHP-9	500	100	740-5MHP-9	740	148	1050-5MHP-9	1050	210
270-5MHP-9	270	54	520-5MHP-9	520	104	750-5MHP-9	750	150	1125-5MHP-9	1125	225
280-5MHP-9	280	56	525-5MHP-9	525	105	755-5MHP-9	755	151	1135-5MHP-9	1135	227
295-5MHP-9	295	59	535-5MHP-9	535	107	775-5MHP-9	775	155	1200-5MHP-9	1200	240
300-5MHP-9	300	60	540-5MHP-9	540	108	790-5MHP-9	790	158	1270-5MHP-9	1270	254
305-5MHP-9	305	61	550-5MHP-9	550	110	800-5MHP-9	800	160	1380-5MHP-9	1380	276
325-5MHP-9	325	65	560-5MHP-9	560	112	825-5MHP-9	825	165	1400-5MHP-9	1400	280
330-5MHP-9	330	66	565-5MHP-9	565	113	830-5MHP-9	830	166	1420-5MHP-9	1420	284
340-5MHP-9	340	68	575-5MHP-9	575	115	835-5MHP-9	835	167	1425-5MHP-9	1425	285
350-5MHP-9	350	70	580-5MHP-9	580	116	850-5MHP-9	850	170	1500-5MHP-9	1500	300
360-5MHP-9	360	72	600-5MHP-9	600	120	860-5MHP-9	860	172	1595-5MHP-9	1595	319
365-5MHP-9	365	73	610-5MHP-9	610	122	890-5MHP-9	890	178	1690-5MHP-9	1690	338
370-5MHP-9	370	74	615-5MHP-9	615	123	900-5MHP-9	900	180	1790-5MHP-9	1790	358
375-5MHP-9	375	75	630-5MHP-9	630	126	925-5MHP-9	925	185	1870-5MHP-9	1870	374
385-5MHP-9	385	77	635-5MHP-9	635	127	935-5MHP-9	935	187	1895-5MHP-9	1895	379
400-5MHP-9	400	80	640-5MHP-9	640	128	940-5MHP-9	940	188	2000-5MHP-9	2000	400
415-5MHP-9	415	83	645-5MHP-9	645	129	950-5MHP-9	950	190	2110-5MHP-9	2110	422
420-5MHP-9	420	84	650-5MHP-9	650	130	965-5MHP-9	965	193	2350-5MHP-9	2350	470
425-5MHP-9	425	85	665-5MHP-9	665	133	975-5MHP-9	975	195	2525-5MHP-9	2525	505
450-5MHP-9	450	90	670-5MHP-9	670	134	980-5MHP-9	980	196			
180-5MHP-9	180	36	385-5MHP-15	385	77	575-5MHP-15	575	115	755-5MHP-15	755	151
225-5MHP-9	225	45	400-5MHP-15	400	80	580-5MHP-15	580	116	775-5MHP-15	775	155
255-5MHP-9	255	51	415-5MHP-15	415	83	600-5MHP-15	600	120	790-5MHP-15	790	158
265-5MHP-9	265	53	420-5MHP-15	420	84	610-5MHP-15	610	122	800-5MHP-15	800	160
270-5MHP-9	270	54	425-5MHP-15	425	85	615-5MHP-15	615	123	825-5MHP-15	825	165
280-5MHP-9	280	56	450-5MHP-15	450	90	630-5MHP-15	630	126	830-5MHP-15	830	166
295-5MHP-9	295	59	460-5MHP-15	460	92	635-5MHP-15	635	127	835-5MHP-15	835	167
300-5MHP-9	300	60	475-5MHP-15	475	95	640-5MHP-15	640	128	850-5MHP-15	850	170
305-5MHP-9	305	61	490-5MHP-15	490	98	645-5MHP-15	645	129	860-5MHP-15	860	172
325-5MHP-9	325	65	500-5MHP-15	500	100	650-5MHP-15	650	130	890-5MHP-15	890	178
330-5MHP-9	330	66	520-5MHP-15	520	104	665-5MHP-15	665	133	900-5MHP-15	900	180
340-5MHP-9	340	68	525-5MHP-15	525	105	670-5MHP-15	670	134	925-5MHP-15	925	185
350-5MHP-9	350	70	535-5MHP-15	535	107	700-5MHP-15	700	140	935-5MHP-15	935	187
360-5MHP-9	360	72	540-5MHP-15	540	108	710-5MHP-15	710	142	940-5MHP-15	940	188
365-5MHP-9	365	73	550-5MHP-15	550	110	720-5MHP-15	720	144	950-5MHP-15	950	190
370-5MHP-9	370	74	560-5MHP-15	560	112	740-5MHP-15	740	148			
375-5MHP-9	375	75	565-5MHP-15	565	113	750-5MHP-15	750	150			

**5M CONTINUED PG 58**

**EXAMPLE SIZING:**

Part Number: 835-5MHP-9 (HP=BELT CONSTRUCTION)  
 835 = 835 mm Pitch Length 5M = Section & Construction 9 = 9 mm Belt Width  
 Part Number: 830-5MHP-15 (HP=BELT CONSTRUCTION)  
 830 = 830 mm Pitch Length 5M = Section & Construction 15 = 15 mm Belt Width

Contact an OPTIBELT representative regarding additional sizes, stock availability and pricing.

**EXPEDITED SHIPPING:** Each OPTIBELT warehouse facility cuts timing belts to width for faster order service.

**HP 5M**  
OMEGA TIMING



5M SECTION 5 MM PITCH

**OMEGA HP TIMING**

SAMPLE PART # : 1500-5MHP-25

PART NUMBER	PITCH LENGTH (MM)	NO. OF TEETH	PART NUMBER	PITCH LENGTH (MM)	NO. OF TEETH	PART NUMBER	PITCH LENGTH (MM)	NO. OF TEETH	PART NUMBER	PITCH LENGTH (MM)	NO. OF TEETH
965-5MHP-15	965	193	1125-5MHP-15	1125	225	1420-5MHP-15	1420	284	1870-5MHP-15	1870	374
975-5MHP-15	975	195	1135-5MHP-15	1135	227	1425-5MHP-15	1425	285	1895-5MHP-15	1895	379
980-5MHP-15	980	196	1200-5MHP-15	1200	240	1500-5MHP-15	1500	300	2000-5MHP-15	2000	400
1000-5MHP-15	1000	200	1270-5MHP-15	1270	254	1595-5MHP-15	1595	319	2110-5MHP-15	2110	422
1025-5MHP-15	1025	205	1380-5MHP-15	1380	276	1690-5MHP-15	1690	338	2350-5MHP-15	2350	470
1035-5MHP-15	1035	207	1400-5MHP-15	1400	280	1790-5MHP-15	1790	358	2525-5MHP-15	2525	505
1050-5MHP-15	1050	210									
180-5MHP-25	180	36	460-5MHP-25	460	92	700-5MHP-25	700	140	1000-5MHP-25	1000	200
225-5MHP-25	225	45	475-5MHP-25	475	95	710-5MHP-25	710	142	1025-5MHP-25	1025	205
255-5MHP-25	255	51	490-5MHP-25	490	98	720-5MHP-25	720	144	1035-5MHP-25	1035	207
265-5MHP-25	265	53	500-5MHP-25	500	100	740-5MHP-25	740	148	1050-5MHP-25	1050	210
270-5MHP-25	270	54	520-5MHP-25	520	104	750-5MHP-25	750	150	1125-5MHP-25	1125	225
280-5MHP-25	280	56	525-5MHP-25	525	105	755-5MHP-25	755	151	1135-5MHP-25	1135	227
295-5MHP-25	295	59	535-5MHP-25	535	107	775-5MHP-25	775	155	1200-5MHP-25	1200	240
300-5MHP-25	300	60	540-5MHP-25	540	108	790-5MHP-25	790	158	1270-5MHP-25	1270	254
305-5MHP-25	305	61	550-5MHP-25	550	110	800-5MHP-25	800	160	1380-5MHP-25	1380	276
325-5MHP-25	325	65	560-5MHP-25	560	112	825-5MHP-25	825	165	1400-5MHP-25	1400	280
330-5MHP-25	330	66	565-5MHP-25	565	113	830-5MHP-25	830	166	1420-5MHP-25	1420	284
340-5MHP-25	340	68	575-5MHP-25	575	115	835-5MHP-25	835	167	1425-5MHP-25	1425	285
350-5MHP-25	350	70	580-5MHP-25	580	116	850-5MHP-25	850	170	1500-5MHP-25	1500	300
360-5MHP-25	360	72	600-5MHP-25	600	120	860-5MHP-25	860	172	1595-5MHP-25	1595	319
365-5MHP-25	365	73	610-5MHP-25	610	122	890-5MHP-25	890	178	1690-5MHP-25	1690	338
370-5MHP-25	370	74	615-5MHP-25	615	123	900-5MHP-25	900	180	1790-5MHP-25	1790	358
375-5MHP-25	375	75	630-5MHP-25	630	126	925-5MHP-25	925	185	1870-5MHP-25	1870	374
385-5MHP-25	385	77	635-5MHP-25	635	127	935-5MHP-25	935	187	1895-5MHP-25	1895	379
400-5MHP-25	400	80	640-5MHP-25	640	128	940-5MHP-25	940	188	2000-5MHP-25	2000	400
415-5MHP-25	415	83	645-5MHP-25	645	129	950-5MHP-25	950	190	2110-5MHP-25	2110	422
420-5MHP-25	420	84	650-5MHP-25	650	130	965-5MHP-25	965	193	2350-5MHP-25	2350	470
425-5MHP-25	425	85	665-5MHP-25	665	133	975-5MHP-25	975	195	2525-5MHP-25	2525	505
450-5MHP-25	450	90	670-5MHP-25	670	134	980-5MHP-25	980	196			

HP 5M  
OMEGA TIMING

**CUT TO SIZE WIDTHS**

If you need a custom width timing belt, OPTIBELT has you covered. Each OPTIBELT facility can cut custom widths. This means you don't have to wait for a manufactured factory order. If it is stocked it can ship!

Contact an OPTIBELT representative regarding additional sizes, stock availability and pricing.

**EXPEDITED SHIPPING:** Each OPTIBELT warehouse facility cuts timing belts to width for faster order service.

**EXAMPLE SIZING:**

Part Number: 1380-5MHP-15 (HP=BELT CONSTRUCTION)

1380 = 1380 mm Pitch Length 5M = Section & Construction 15 = 15 mm Belt Width

Part Number: 330-5MHP-25 (HP=BELT CONSTRUCTION)

330 = 330 mm Pitch Length 5M = Section & Construction 25 = 25 mm Belt Width



SAMPLE PART # : 1280-8MHP-20

**OMEGA HP TIMING**

8M SECTION 8 MM PITCH

PART NUMBER	PITCH LENGTH (MM)	NO. OF TEETH	PART NUMBER	PITCH LENGTH (MM)	NO. OF TEETH	PART NUMBER	PITCH LENGTH (MM)	NO. OF TEETH	PART NUMBER	PITCH LENGTH (MM)	NO. OF TEETH
288-8MHP-20	288	36	776-8MHP-20	776	97	1128-8MHP-20	1128	141	1600-8MHP-20	1600	200
352-8MHP-20	352	44	784-8MHP-20	784	98	1160-8MHP-20	1160	145	1680-8MHP-20	1680	210
376-8MHP-20	376	47	800-8MHP-20	800	100	1184-8MHP-20	1184	148	1696-8MHP-20	1696	212
416-8MHP-20	416	52	824-8MHP-20	824	103	1200-8MHP-20	1200	150	1728-8MHP-20	1728	216
424-8MHP-20	424	53	840-8MHP-20	840	105	1216-8MHP-20	1216	152	1760-8MHP-20	1760	220
480-8MHP-20	480	60	848-8MHP-20	848	106	1224-8MHP-20	1224	153	1800-8MHP-20	1800	225
512-8MHP-20	512	64	856-8MHP-20	856	107	1248-8MHP-20	1248	156	1904-8MHP-20	1904	238
520-8MHP-20	520	65	880-8MHP-20	880	110	1256-8MHP-20	1256	157	1936-8MHP-20	1936	242
560-8MHP-20	560	70	896-8MHP-20	896	112	1264-8MHP-20	1264	158	2000-8MHP-20	2000	250
576-8MHP-20	576	72	912-8MHP-20	912	114	1280-8MHP-20	1280	160	2080-8MHP-20	2080	260
600-8MHP-20	600	75	920-8MHP-20	920	115	1304-8MHP-20	1304	163	2104-8MHP-20	2104	263
608-8MHP-20	608	76	960-8MHP-20	960	120	1328-8MHP-20	1328	166	2240-8MHP-20	2240	280
624-8MHP-20	624	78	976-8MHP-20	976	122	1344-8MHP-20	1344	168	2248-8MHP-20	2248	281
632-8MHP-20	632	79	1000-8MHP-20	1000	125	1360-8MHP-20	1360	170	2272-8MHP-20	2272	284
640-8MHP-20	640	80	1040-8MHP-20	1040	130	1400-8MHP-20	1400	175	2400-8MHP-20	2400	300
656-8MHP-20	656	82	1056-8MHP-20	1056	132	1424-8MHP-20	1424	178	2504-8MHP-20	2504	313
680-8MHP-20	680	85	1064-8MHP-20	1064	133	1440-8MHP-20	1440	180	2600-8MHP-20	2600	325
712-8MHP-20	712	89	1080-8MHP-20	1080	135	1520-8MHP-20	1520	190	2800-8MHP-20	2800	350
720-8MHP-20	720	90	1096-8MHP-20	1096	137	1552-8MHP-20	1552	194	3280-8MHP-20	3280	410
760-8MHP-20	760	95	1120-8MHP-20	1120	140	1584-8MHP-20	1584	198			
288-8MHP-30	288	36	776-8MHP-30	776	97	1128-8MHP-30	1128	141	1600-8MHP-30	1600	200
352-8MHP-30	352	44	784-8MHP-30	784	98	1160-8MHP-30	1160	145	1680-8MHP-30	1680	210
376-8MHP-30	376	47	800-8MHP-30	800	100	1184-8MHP-30	1184	148	1696-8MHP-30	1696	212
416-8MHP-30	416	52	824-8MHP-30	824	103	1200-8MHP-30	1200	150	1728-8MHP-30	1728	216
424-8MHP-30	424	53	840-8MHP-30	840	105	1216-8MHP-30	1216	152	1760-8MHP-30	1760	220
480-8MHP-30	480	60	848-8MHP-30	848	106	1224-8MHP-30	1224	153	1800-8MHP-30	1800	225
512-8MHP-30	512	64	856-8MHP-30	856	107	1248-8MHP-30	1248	156	1904-8MHP-30	1904	238
520-8MHP-30	520	65	880-8MHP-30	880	110	1256-8MHP-30	1256	157	1936-8MHP-30	1936	242
560-8MHP-30	560	70	896-8MHP-30	896	112	1264-8MHP-30	1264	158	2000-8MHP-30	2000	250
576-8MHP-30	576	72	912-8MHP-30	912	114	1280-8MHP-30	1280	160	2080-8MHP-30	2080	260
600-8MHP-30	600	75	920-8MHP-30	920	115	1304-8MHP-30	1304	163	2104-8MHP-30	2104	263
608-8MHP-30	608	76	960-8MHP-30	960	120	1328-8MHP-30	1328	166	2240-8MHP-30	2240	280
624-8MHP-30	624	78	976-8MHP-30	976	122	1344-8MHP-30	1344	168	2248-8MHP-30	2248	281
632-8MHP-30	632	79	1000-8MHP-30	1000	125	1360-8MHP-30	1360	170	2272-8MHP-30	2272	284
640-8MHP-30	640	80	1040-8MHP-30	1040	130	1400-8MHP-30	1400	175	2400-8MHP-30	2400	300
656-8MHP-30	656	82	1056-8MHP-30	1056	132	1424-8MHP-30	1424	178	2504-8MHP-30	2504	313
680-8MHP-30	680	85	1064-8MHP-30	1064	133	1440-8MHP-30	1440	180	2600-8MHP-30	2600	325
712-8MHP-30	712	89	1080-8MHP-30	1080	135	1520-8MHP-30	1520	190	2800-8MHP-30	2800	350
720-8MHP-30	720	90	1096-8MHP-30	1096	137	1552-8MHP-30	1552	194	3280-8MHP-30	3280	410
760-8MHP-30	760	95	1120-8MHP-30	1120	140	1584-8MHP-30	1584	198			

**8M CONTINUED PG 60**

**HP 8M**  
OMEGA TIMING

**EXAMPLE SIZING:**

Part Number: 576-8MHP-20 (HP=BELT CONSTRUCTION)  
 576 = 576 mm Pitch Length 8M = Section & Construction 20 = 20 mm Belt Width  
 Part Number: 1304-8MHP-30 (HP=BELT CONSTRUCTION)  
 1304 = 1304 mm Pitch Length 8M = Section & Construction 30 = 30 mm Belt Width

Contact an OPTIBELT representative regarding additional sizes, stock availability and pricing.

**EXPEDITED SHIPPING:** Each OPTIBELT warehouse facility cuts timing belts to width for faster order service.



8M SECTION 8 MM PITCH

**OMEGA HP TIMING**

SAMPLE PART # : 1128-8MHP-85

PART NUMBER	PITCH LENGTH (MM)	NO. OF TEETH	PART NUMBER	PITCH LENGTH (MM)	NO. OF TEETH	PART NUMBER	PITCH LENGTH (MM)	NO. OF TEETH	PART NUMBER	PITCH LENGTH (MM)	NO. OF TEETH
288-8MHP-50	288	36	776-8MHP-50	776	97	1128-8MHP-50	1128	141	1600-8MHP-50	1600	200
352-8MHP-50	352	44	784-8MHP-50	784	98	1160-8MHP-50	1160	145	1680-8MHP-50	1680	210
376-8MHP-50	376	47	800-8MHP-50	800	100	1184-8MHP-50	1184	148	1696-8MHP-50	1696	212
416-8MHP-50	416	52	824-8MHP-50	824	103	1200-8MHP-50	1200	150	1728-8MHP-50	1728	216
424-8MHP-50	424	53	840-8MHP-50	840	105	1216-8MHP-50	1216	152	1760-8MHP-50	1760	220
480-8MHP-50	480	60	848-8MHP-50	848	106	1224-8MHP-50	1224	153	1800-8MHP-50	1800	225
512-8MHP-50	512	64	856-8MHP-50	856	107	1248-8MHP-50	1248	156	1904-8MHP-50	1904	238
520-8MHP-50	520	65	880-8MHP-50	880	110	1256-8MHP-50	1256	157	1936-8MHP-50	1936	242
560-8MHP-50	560	70	896-8MHP-50	896	112	1264-8MHP-50	1264	158	2000-8MHP-50	2000	250
576-8MHP-50	576	72	912-8MHP-50	912	114	1280-8MHP-50	1280	160	2080-8MHP-50	2080	260
600-8MHP-50	600	75	920-8MHP-50	920	115	1304-8MHP-50	1304	163	2104-8MHP-50	2104	263
608-8MHP-50	608	76	960-8MHP-50	960	120	1328-8MHP-50	1328	166	2240-8MHP-50	2240	280
624-8MHP-50	624	78	976-8MHP-50	976	122	1344-8MHP-50	1344	168	2248-8MHP-50	2248	281
632-8MHP-50	632	79	1000-8MHP-50	1000	125	1360-8MHP-50	1360	170	2272-8MHP-50	2272	284
640-8MHP-50	640	80	1040-8MHP-50	1040	130	1400-8MHP-50	1400	175	2400-8MHP-50	2400	300
656-8MHP-50	656	82	1056-8MHP-50	1056	132	1424-8MHP-50	1424	178	2504-8MHP-50	2504	313
680-8MHP-50	680	85	1064-8MHP-50	1064	133	1440-8MHP-50	1440	180	2600-8MHP-50	2600	325
712-8MHP-50	712	89	1080-8MHP-50	1080	135	1520-8MHP-50	1520	190	2800-8MHP-50	2800	350
720-8MHP-50	720	90	1096-8MHP-50	1096	137	1552-8MHP-50	1552	194	3280-8MHP-50	3280	410
760-8MHP-50	760	95	1120-8MHP-50	1120	140	1584-8MHP-50	1584	198			
288-8MHP-85	288	36	776-8MHP-85	776	97	1128-8MHP-85	1128	141	1600-8MHP-85	1600	200
352-8MHP-85	352	44	784-8MHP-85	784	98	1160-8MHP-85	1160	145	1680-8MHP-85	1680	210
376-8MHP-85	376	47	800-8MHP-85	800	100	1184-8MHP-85	1184	148	1696-8MHP-85	1696	212
416-8MHP-85	416	52	824-8MHP-85	824	103	1200-8MHP-85	1200	150	1728-8MHP-85	1728	216
424-8MHP-85	424	53	840-8MHP-85	840	105	1216-8MHP-85	1216	152	1760-8MHP-85	1760	220
480-8MHP-85	480	60	848-8MHP-85	848	106	1224-8MHP-85	1224	153	1800-8MHP-85	1800	225
512-8MHP-85	512	64	856-8MHP-85	856	107	1248-8MHP-85	1248	156	1904-8MHP-85	1904	238
520-8MHP-85	520	65	880-8MHP-85	880	110	1256-8MHP-85	1256	157	1936-8MHP-85	1936	242
560-8MHP-85	560	70	896-8MHP-85	896	112	1264-8MHP-85	1264	158	2000-8MHP-85	2000	250
576-8MHP-85	576	72	912-8MHP-85	912	114	1280-8MHP-85	1280	160	2080-8MHP-85	2080	260
600-8MHP-85	600	75	920-8MHP-85	920	115	1304-8MHP-85	1304	163	2104-8MHP-85	2104	263
608-8MHP-85	608	76	960-8MHP-85	960	120	1328-8MHP-85	1328	166	2240-8MHP-85	2240	280
624-8MHP-85	624	78	976-8MHP-85	976	122	1344-8MHP-85	1344	168	2248-8MHP-85	2248	281
632-8MHP-85	632	79	1000-8MHP-85	1000	125	1360-8MHP-85	1360	170	2272-8MHP-85	2272	284
640-8MHP-85	640	80	1040-8MHP-85	1040	130	1400-8MHP-85	1400	175	2400-8MHP-85	2400	300
656-8MHP-85	656	82	1056-8MHP-85	1056	132	1424-8MHP-85	1424	178	2504-8MHP-85	2504	313
680-8MHP-85	680	85	1064-8MHP-85	1064	133	1440-8MHP-85	1440	180	2600-8MHP-85	2600	325
712-8MHP-85	712	89	1080-8MHP-85	1080	135	1520-8MHP-85	1520	190	2800-8MHP-85	2800	350
720-8MHP-85	720	90	1096-8MHP-85	1096	137	1552-8MHP-85	1552	194	3280-8MHP-85	3280	410
760-8MHP-85	760	95	1120-8MHP-85	1120	140	1584-8MHP-85	1584	198			

HP 8M  
OMEGA TIMING

Contact an OPTIBELT representative regarding additional sizes, stock availability and pricing.

**EXPEDITED SHIPPING:** Each OPTIBELT warehouse facility cuts timing belts to width for faster order service.

**EXAMPLE SIZING:**

Part Number: 960-8MHP-50 (HP=BELT CONSTRUCTION)

960 = 960 mm Pitch Length 8M = Section & Construction 50 = 50 mm Belt Width

Part Number: 1800-8MHP-85 (HP=BELT CONSTRUCTION)

1800 = 1800 mm Pitch Length 8M = Section & Construction 85 = 85 mm Belt Width



SAMPLE PART # : 1680-14MHP-55

**OMEGA HP TIMING**

**14M** SECTION 14 MM PITCH

PART NUMBER	PITCH LENGTH (MM)	NO. OF TEETH	PART NUMBER	PITCH LENGTH (MM)	NO. OF TEETH	PART NUMBER	PITCH LENGTH (MM)	NO. OF TEETH	PART NUMBER	PITCH LENGTH (MM)	NO. OF TEETH
966-14MHP-40	966	69	1512-14MHP-40	1512	108	2310-14MHP-40	2310	165	3360-14MHP-40	3360	240
1092-14MHP-40	1092	78	1610-14MHP-40	1610	115	2450-14MHP-40	2450	175	3500-14MHP-40	3500	250
1190-14MHP-40	1190	85	1680-14MHP-40	1680	120	2590-14MHP-40	2590	185	3850-14MHP-40	3850	275
1344-14MHP-40	1344	96	1778-14MHP-40	1778	127	2800-14MHP-40	2800	200	4326-14MHP-40	4326	309
1400-14MHP-40	1400	100	1890-14MHP-40	1890	135	3150-14MHP-40	3150	225	4578-14MHP-40	4578	327
1456-14MHP-40	1456	104	2100-14MHP-40	2100	150						
966-14MHP-55	966	69	1512-14MHP-55	1512	108	2310-14MHP-55	2310	165	3360-14MHP-55	3360	240
1092-14MHP-55	1092	78	1610-14MHP-55	1610	115	2450-14MHP-55	2450	175	3500-14MHP-55	3500	250
1190-14MHP-55	1190	85	1680-14MHP-55	1680	120	2590-14MHP-55	2590	185	3850-14MHP-55	3850	275
1344-14MHP-55	1344	96	1778-14MHP-55	1778	127	2800-14MHP-55	2800	200	4326-14MHP-55	4326	309
1400-14MHP-55	1400	100	1890-14MHP-55	1890	135	3150-14MHP-55	3150	225	4578-14MHP-55	4578	327
1456-14MHP-55	1456	104	2100-14MHP-55	2100	150						
966-14MHP-85	966	69	1512-14MHP-85	1512	108	2310-14MHP-85	2310	165	3360-14MHP-85	3360	240
1092-14MHP-85	1092	78	1610-14MHP-85	1610	115	2450-14MHP-85	2450	175	3500-14MHP-85	3500	250
1190-14MHP-85	1190	85	1680-14MHP-85	1680	120	2590-14MHP-85	2590	185	3850-14MHP-85	3850	275
1344-14MHP-85	1344	96	1778-14MHP-85	1778	127	2800-14MHP-85	2800	200	4326-14MHP-85	4326	309
1400-14MHP-85	1400	100	1890-14MHP-85	1890	135	3150-14MHP-85	3150	225	4578-14MHP-85	4578	327
1456-14MHP-85	1456	104	2100-14MHP-85	2100	150						
966-14MHP-115	966	69	1512-14MHP-115	1512	108	2310-14MHP-115	2310	165	3360-14MHP-115	3360	240
1092-14MHP-115	1092	78	1610-14MHP-115	1610	115	2450-14MHP-115	2450	175	3500-14MHP-115	3500	250
1190-14MHP-115	1190	85	1680-14MHP-115	1680	120	2590-14MHP-115	2590	185	3850-14MHP-115	3850	275
1344-14MHP-115	1344	96	1778-14MHP-115	1778	127	2800-14MHP-115	2800	200	4326-14MHP-115	4326	309
1400-14MHP-115	1400	100	1890-14MHP-115	1890	135	3150-14MHP-115	3150	225	4578-14MHP-115	4578	327
1456-14MHP-115	1456	104	2100-14MHP-115	2100	150						
966-14MHP-170	966	69	1512-14MHP-170	1512	108	2310-14MHP-170	2310	165	3360-14MHP-170	3360	240
1092-14MHP-170	1092	78	1610-14MHP-170	1610	115	2450-14MHP-170	2450	175	3500-14MHP-170	3500	250
1190-14MHP-170	1190	85	1680-14MHP-170	1680	120	2590-14MHP-170	2590	185	3850-14MHP-170	3850	275
1344-14MHP-170	1344	96	1778-14MHP-170	1778	127	2800-14MHP-170	2800	200	4326-14MHP-170	4326	309
1400-14MHP-170	1400	100	1890-14MHP-170	1890	135	3150-14MHP-170	3150	225	4578-14MHP-170	4578	327
1456-14MHP-170	1456	104	2100-14MHP-170	2100	150						

**CUT TO SIZE WIDTHS**

If you need a custom width timing belt, OPTIBELT has you covered. Each OPTIBELT facility can cut custom widths. This means you don't have to wait for a manufactured factory order. If it is stocked it can ship!

**EXAMPLE SIZING:**

Part Number: 2800-14MHP-85 (HP=BELT CONSTRUCTION)  
 2800 = 2800 mm Pitch Length 14M = Section & Construction 85 = 85 mm Belt Width  
 Part Number: 1092-14MHP-170 (HP=BELT CONSTRUCTION)  
 1092 = 1092 mm Pitch Length 14M = Section & Construction 170 = 170 mm Belt Width

Contact an OPTIBELT representative regarding additional sizes, stock availability and pricing.

**EXPEDITED SHIPPING:** Each OPTIBELT warehouse facility cuts timing belts to width for faster order service.



2M SECTION 2 MM PITCH

**OMEGA TIMING**

SAMPLE PART # : 232-2M-6

PART NUMBER	PITCH LENGTH (MM)	NO. OF TEETH
90-2M-3	90	45
100-2M-3	100	50
104-2M-3	104	52
112-2M-3	112	56
118-2M-3	118	59
120-2M-3	120	60
124-2M-3	124	62
130-2M-3	130	65
140-2M-3	140	70

PART NUMBER	PITCH LENGTH (MM)	NO. OF TEETH
148-2M-3	148	74
180-2M-3	180	90
184-2M-3	184	92
188-2M-3	188	94
200-2M-3	200	100
208-2M-3	208	104
216-2M-3	216	108
232-2M-3	232	116
250-2M-3	250	125

PART NUMBER	PITCH LENGTH (MM)	NO. OF TEETH
266-2M-3	266	133
274-2M-3	274	137
280-2M-3	280	140
286-2M-3	286	143
308-2M-3	308	154
310-2M-3	310	155
328-2M-3	328	164
330-2M-3	330	165
340-2M-3	340	170

PART NUMBER	PITCH LENGTH (MM)	NO. OF TEETH
370-2M-3	370	185
426-2M-3	426	213
448-2M-3	448	224
558-2M-3	558	279
560-2M-3	560	280
710-2M-3	710	355
984-2M-3	984	492
1066-2M-3	1066	533
1224-2M-3	1224	612

PART NUMBER	PITCH LENGTH (MM)	NO. OF TEETH
90-2M-6	90	45
100-2M-6	100	50
104-2M-6	104	52
112-2M-6	112	56
118-2M-6	118	59
120-2M-6	120	60
124-2M-6	124	62
130-2M-6	130	65
140-2M-6	140	70

PART NUMBER	PITCH LENGTH (MM)	NO. OF TEETH
148-2M-6	148	74
180-2M-6	180	90
184-2M-6	184	92
188-2M-6	188	94
200-2M-6	200	100
208-2M-6	208	104
216-2M-6	216	108
232-2M-6	232	116
250-2M-6	250	125

PART NUMBER	PITCH LENGTH (MM)	NO. OF TEETH
266-2M-6	266	133
274-2M-6	274	137
280-2M-6	280	140
286-2M-6	286	143
308-2M-6	308	154
310-2M-6	310	155
328-2M-6	328	164
330-2M-6	330	165
340-2M-6	340	170

PART NUMBER	PITCH LENGTH (MM)	NO. OF TEETH
370-2M-6	370	185
426-2M-6	426	213
448-2M-6	448	224
558-2M-6	558	279
560-2M-6	560	280
710-2M-6	710	355
984-2M-6	984	492
1066-2M-6	1066	533
1224-2M-6	1224	612

PART NUMBER	PITCH LENGTH (MM)	NO. OF TEETH
90-2M-9	90	45
100-2M-9	100	50
104-2M-9	104	52
112-2M-9	112	56
118-2M-9	118	59
120-2M-9	120	60
124-2M-9	124	62
130-2M-9	130	65
140-2M-9	140	70

PART NUMBER	PITCH LENGTH (MM)	NO. OF TEETH
148-2M-9	148	74
180-2M-9	180	90
184-2M-9	184	92
188-2M-9	188	94
200-2M-9	200	100
208-2M-9	208	104
216-2M-9	216	108
232-2M-9	232	116
250-2M-9	250	125

PART NUMBER	PITCH LENGTH (MM)	NO. OF TEETH
266-2M-9	266	133
274-2M-9	274	137
280-2M-9	280	140
286-2M-9	286	143
308-2M-9	308	154
310-2M-9	310	155
328-2M-9	328	164
330-2M-9	330	165
340-2M-9	340	170

PART NUMBER	PITCH LENGTH (MM)	NO. OF TEETH
370-2M-9	370	185
426-2M-9	426	213
448-2M-9	448	224
558-2M-9	558	279
560-2M-9	560	280
710-2M-9	710	355
984-2M-9	984	492
1066-2M-9	1066	533
1224-2M-9	1224	612

**CUT TO SIZE WIDTHS**

If you need a custom width timing belt, OPTIBELT has you covered. Each OPTIBELT facility can cut custom widths. This means you don't have to wait for a manufactured factory order. If it is stocked it can ship!

OMEGA 2M  
OMEGA TIMING

Contact an OPTIBELT representative regarding additional sizes, stock availability and pricing.

**EXPEDITED SHIPPING:** Each OPTIBELT warehouse facility cuts timing belts to width for faster order service.

**EXAMPLE SIZING:**

Part Number: 184-2M-3

184 = 184 mm Pitch Length 2M = Section & Construction 3 = 3 mm Belt Width

Part Number: 308-2M-9

308 = 150 mm Pitch Length 2M = Section & Construction 9 = 9 mm Belt Width





SAMPLE PART # :339-3M-6

**OMEGA TIMING**

**3M SECTION 3 MM PITCH**

PART NUMBER	PITCH LENGTH (MM)	NO. OF TEETH
111-3M-6	111	37
129-3M-6	129	43
141-3M-6	141	47
144-3M-6	144	48
150-3M-6	150	50
165-3M-6	165	55
168-3M-6	168	56
174-3M-6	174	58
177-3M-6	177	59
180-3M-6	180	60
183-3M-6	183	61
186-3M-6	186	62
192-3M-6	192	64
195-3M-6	195	65
201-3M-6	201	67
204-3M-6	204	68
207-3M-6	207	69
210-3M-6	210	70
213-3M-6	213	71

PART NUMBER	PITCH LENGTH (MM)	NO. OF TEETH
225-3M-6	225	75
240-3M-6	240	80
252-3M-6	252	84
255-3M-6	255	85
267-3M-6	267	89
285-3M-6	285	85
288-3M-6	288	96
291-3M-6	291	97
294-3M-6	294	98
300-3M-6	300	100
312-3M-6	312	104
315-3M-6	315	105
318-3M-6	318	106
330-3M-6	330	110
339-3M-6	339	113
345-3M-6	345	115
357-3M-6	357	119
363-3M-6	363	121
366-3M-6	366	122

PART NUMBER	PITCH LENGTH (MM)	NO. OF TEETH
384-3M-6	384	128
390-3M-6	390	130
420-3M-6	420	140
426-3M-6	426	142
447-3M-6	447	149
462-3M-6	462	154
474-3M-6	474	158
480-3M-6	480	160
486-3M-6	486	162
495-3M-6	495	165
501-3M-6	501	167
513-3M-6	513	171
519-3M-6	519	173
522-3M-6	522	174
525-3M-6	525	175
531-3M-6	531	177
537-3M-6	537	179
558-3M-6	558	186

PART NUMBER	PITCH LENGTH (MM)	NO. OF TEETH
564-3M-6	564	188
570-3M-6	570	190
597-3M-6	597	199
600-3M-6	600	200
606-3M-6	606	202
615-3M-6	615	205
633-3M-6	633	211
669-3M-6	669	223
675-3M-6	675	225
711-3M-6	711	237
738-3M-6	738	237
804-3M-6	804	268
843-3M-6	843	281
882-3M-6	882	294
888-3M-6	888	296
1062-3M-6	1062	354
1569-3M-6	1569	523
1587-3M-6	1587	529

PART NUMBER	PITCH LENGTH (MM)	NO. OF TEETH
111-3M-9	111	37
129-3M-9	129	43
141-3M-9	141	47
144-3M-9	144	48
150-3M-9	150	50
165-3M-9	165	55
168-3M-9	168	56
174-3M-9	174	58
177-3M-9	177	59
180-3M-9	180	60
183-3M-9	183	61
186-3M-9	186	62
192-3M-9	192	64
195-3M-9	195	65
201-3M-9	201	67
204-3M-9	204	68
207-3M-9	207	69
210-3M-9	210	70
213-3M-9	213	71

PART NUMBER	PITCH LENGTH (MM)	NO. OF TEETH
225-3M-9	225	75
240-3M-9	240	80
252-3M-9	252	84
255-3M-9	255	85
267-3M-9	267	89
285-3M-9	285	85
288-3M-9	288	96
291-3M-9	291	97
294-3M-9	294	98
300-3M-9	300	100
312-3M-9	312	104
315-3M-9	315	105
318-3M-9	318	106
330-3M-9	330	110
339-3M-9	339	113
345-3M-9	345	115
357-3M-9	357	119
363-3M-9	363	121
366-3M-9	366	122

PART NUMBER	PITCH LENGTH (MM)	NO. OF TEETH
384-3M-9	384	128
390-3M-9	390	130
420-3M-9	420	140
426-3M-9	426	142
447-3M-9	447	149
462-3M-9	462	154
474-3M-9	474	158
480-3M-9	480	160
486-3M-9	486	162
495-3M-9	495	165
501-3M-9	501	167
513-3M-9	513	171
519-3M-9	519	173
522-3M-9	522	174
525-3M-9	525	175
531-3M-9	531	177
537-3M-9	537	179
558-3M-9	558	186
564-3M-9	564	188

PART NUMBER	PITCH LENGTH (MM)	NO. OF TEETH
570-3M-9	570	190
597-3M-9	597	199
600-3M-9	600	200
606-3M-9	606	202
615-3M-9	615	205
633-3M-9	633	211
669-3M-9	669	223
675-3M-9	675	225
711-3M-9	711	237
738-3M-9	738	237
804-3M-9	804	268
843-3M-9	843	281
882-3M-9	882	294
888-3M-9	888	296
1062-3M-9	1062	354
1569-3M-9	1569	523
1587-3M-9	1587	529

**3M CONTINUED PG 64**

**OMEGA 3M**  
OMEGA TIMING

**EXAMPLE SIZING:**  
Part Number: 711-3M-6  
711 = 711 mm Pitch Length 3M = Section & Construction 6 = 6 mm Belt Width  
Part Number: 183-3M-9  
183 = 183 mm Pitch Length 3M = Section & Construction 9 = 9 mm Belt Width

Contact an OPTIBELT representative regarding additional sizes, stock availability and pricing.  
**EXPEDITED SHIPPING:** Each OPTIBELT warehouse facility cuts timing belts to width for faster order service.



**3M SECTION 3 MM PITCH**

**OMEGA TIMING**

SAMPLE PART # : 300-3M-15

PART NUMBER	PITCH LENGTH (MM)	NO. OF TEETH
111-3M-15	111	37
129-3M-15	129	43
141-3M-15	141	47
144-3M-15	144	48
150-3M-15	150	50
165-3M-15	165	55
168-3M-15	168	56
174-3M-15	174	58
177-3M-15	177	59
180-3M-15	180	60
183-3M-15	183	61
186-3M-15	186	62
192-3M-15	192	64
195-3M-15	195	65
201-3M-15	201	67
204-3M-15	204	68
207-3M-15	207	69
210-3M-15	210	70
213-3M-15	213	71

PART NUMBER	PITCH LENGTH (MM)	NO. OF TEETH
225-3M-15	225	75
240-3M-15	240	80
252-3M-15	252	84
255-3M-15	255	85
267-3M-15	267	89
285-3M-15	285	85
288-3M-15	288	96
291-3M-15	291	97
294-3M-15	294	98
300-3M-15	300	100
312-3M-15	312	104
315-3M-15	315	105
318-3M-15	318	106
330-3M-15	330	110
339-3M-15	339	113
345-3M-15	345	115
357-3M-15	357	119
363-3M-15	363	121
366-3M-15	366	122

PART NUMBER	PITCH LENGTH (MM)	NO. OF TEETH
384-3M-15	384	128
390-3M-15	390	130
420-3M-15	420	140
426-3M-15	426	142
447-3M-15	447	149
462-3M-15	462	154
474-3M-15	474	158
480-3M-15	480	160
486-3M-15	486	162
495-3M-15	495	165
501-3M-15	501	167
513-3M-15	513	171
519-3M-15	519	173
522-3M-15	522	174
525-3M-15	525	175
531-3M-15	531	177
537-3M-15	537	179
558-3M-15	558	186

PART NUMBER	PITCH LENGTH (MM)	NO. OF TEETH
564-3M-15	564	188
570-3M-15	570	190
597-3M-15	597	199
600-3M-15	600	200
606-3M-15	606	202
615-3M-15	615	205
633-3M-15	633	211
669-3M-15	669	223
675-3M-15	675	225
711-3M-15	711	237
738-3M-15	738	237
804-3M-15	804	268
843-3M-15	843	281
882-3M-15	882	294
888-3M-15	888	296
1062-3M-15	1062	354
1569-3M-15	1569	523
1587-3M-15	1587	529

**CUT TO SIZE WIDTHS**

If you need a custom width timing belt, OPTIBELT has you covered. Each OPTIBELT facility can cut custom widths. This means you don't have to wait for a manufactured factory order. If it is stocked it can ship!

Contact an OPTIBELT representative regarding additional sizes, stock availability and pricing.

**EXPEDITED SHIPPING:** Each OPTIBELT warehouse facility cuts timing belts to width for faster order service.

**EXAMPLE SIZING:**

Part Number: 294-3M-15

294 = 294 mm Pitch Length 3M = Section Size 15 = 15 mm Belt Width

Part Number: 1062-3M-15

1062 = 1062 mm Pitch Length 3M = Section Size 15 = 15 mm Belt Width



SAMPLE PART # : 400-5M-15

**OMEGA TIMING**

**5M SECTION 5 MM PITCH**

PART NUMBER	PITCH LENGTH (MM)	NO. OF TEETH
180-5M-9	180	36
225-5M-9	225	45
255-5M-9	255	51
265-5M-9	265	53
270-5M-9	270	54
280-5M-9	280	56
295-5M-9	295	59
305-5M-9	305	61
325-5M-9	325	65
330-5M-9	330	66
340-5M-9	340	68
350-5M-9	350	70
360-5M-9	360	72
365-5M-9	365	73
370-5M-9	370	74
375-5M-9	375	75
385-5M-9	385	77
400-5M-9	400	80
415-5M-9	415	83
425-5M-9	425	85
450-5M-9	450	90

PART NUMBER	PITCH LENGTH (MM)	NO. OF TEETH
475-5M-9	475	95
490-5M-9	490	98
500-5M-9	500	100
520-5M-9	520	104
525-5M-9	525	105
535-5M-9	535	107
540-5M-9	540	108
550-5M-9	550	110
560-5M-9	560	112
565-5M-9	565	113
575-5M-9	575	115
580-5M-9	580	116
600-5M-9	600	120
610-5M-9	610	122
615-5M-9	615	123
630-5M-9	630	126
635-5M-9	635	127
640-5M-9	640	128
645-5M-9	645	129
665-5M-9	665	133

PART NUMBER	PITCH LENGTH (MM)	NO. OF TEETH
670-5M-9	670	134
700-5M-9	700	140
710-5M-9	710	142
740-5M-9	740	148
750-5M-9	750	150
755-5M-9	755	151
775-5M-9	775	155
790-5M-9	790	158
800-5M-9	800	160
825-5M-9	825	165
835-5M-9	835	167
850-5M-9	850	170
860-5M-9	860	172
890-5M-9	890	178
900-5M-9	900	180
925-5M-9	925	185
935-5M-9	935	187
950-5M-9	950	190
965-5M-9	965	193
980-5M-9	980	196

PART NUMBER	PITCH LENGTH (MM)	NO. OF TEETH
1000-5M-9	1000	200
1035-5M-9	1035	207
1050-5M-9	1050	210
1100-5M-9	1100	220
1125-5M-9	1125	225
1135-5M-9	1135	227
1200-5M-9	1200	240
1270-5M-9	1270	254
1420-5M-9	1420	284
1425-5M-9	1425	285
1500-5M-9	1500	300
1595-5M-9	1595	319
1690-5M-9	1690	338
1790-5M-9	1790	358
1870-5M-9	1870	374
1895-5M-9	1895	379
2000-5M-9	2000	400
2110-5M-9	2110	422
2350-5M-9	2350	470
2525-5M-9	2525	505

180-5M-15	180	36
225-5M-15	225	45
255-5M-15	255	51
265-5M-15	265	53
270-5M-15	270	54
280-5M-15	280	56
295-5M-15	295	59
305-5M-15	305	61
325-5M-15	325	65
330-5M-15	330	66
340-5M-15	340	68
350-5M-15	350	70
360-5M-15	360	72
365-5M-15	365	73
370-5M-15	370	74
375-5M-15	375	75
385-5M-15	385	77

400-5M-15	400	80
415-5M-15	415	83
425-5M-15	425	85
450-5M-15	450	90
475-5M-15	475	95
490-5M-15	490	98
500-5M-15	500	100
520-5M-15	520	104
525-5M-15	525	105
535-5M-15	535	107
540-5M-15	540	108
550-5M-15	550	110
560-5M-15	560	112
565-5M-15	565	113
575-5M-15	575	115
580-5M-15	580	116
600-5M-15	600	120

610-5M-15	610	122
615-5M-15	615	123
630-5M-15	630	126
635-5M-15	635	127
640-5M-15	640	128
645-5M-15	645	129
665-5M-15	665	133
670-5M-15	670	134
700-5M-15	700	140
710-5M-15	710	142
740-5M-15	740	148
750-5M-15	750	150
755-5M-15	755	151
775-5M-15	775	155
790-5M-15	790	158
800-5M-15	800	160
825-5M-15	825	165

835-5M-15	835	167
850-5M-15	850	170
860-5M-15	860	172
890-5M-15	890	178
900-5M-15	900	180
925-5M-15	925	185
935-5M-15	935	187
950-5M-15	950	190
965-5M-15	965	193
980-5M-15	980	196
1000-5M-15	1000	200
1035-5M-15	1035	207
1050-5M-15	1050	210
1100-5M-15	1100	220
1125-5M-15	1125	225

**5M CONTINUED PG#**

**OMEGA 5M**  
OMEGA TIMING

**EXAMPLE SIZING:**

Part Number: 365-5M-9

365 = 365 mm Pitch Length 5M = Section Size 9 = 9 mm Belt Width

Part Number: 800-5M-15

800 = 800 mm Pitch Length 5M = Section Size 15 = 15 mm Belt Width

Contact an OPTIBELT representative regarding additional sizes, stock availability and pricing.

**EXPEDITED SHIPPING:** Each OPTIBELT warehouse facility cuts timing belts to width for faster order service.



**5M SECTION 5 MM PITCH**

**OMEGA TIMING**

SAMPLE PART # : 1100-5M-25

PART NUMBER	PITCH LENGTH (MM)	NO. OF TEETH
1135-5M-15	1135	227
1200-5M-15	1200	240
1270-5M-15	1270	254
1420-5M-15	1420	284
180-5M-25	180	36
225-5M-25	225	45
255-5M-25	255	51
265-5M-25	265	53
270-5M-25	270	54
280-5M-25	280	56
295-5M-25	295	59
305-5M-25	305	61
325-5M-25	325	65
330-5M-25	330	66
340-5M-25	340	68
350-5M-25	350	70
360-5M-25	360	72
365-5M-25	365	73
370-5M-25	370	74
375-5M-25	375	75
385-5M-25	385	77
400-5M-25	400	80
415-5M-25	415	83
425-5M-25	425	85
450-5M-25	450	90

PART NUMBER	PITCH LENGTH (MM)	NO. OF TEETH
1425-5M-15	1425	285
1500-5M-15	1500	300
1595-5M-15	1595	319
1690-5M-15	1690	338
475-5M-25	475	95
490-5M-25	490	98
500-5M-25	500	100
520-5M-25	520	104
525-5M-25	525	105
535-5M-25	535	107
540-5M-25	540	108
550-5M-25	550	110
560-5M-25	560	112
565-5M-25	565	113
575-5M-25	575	115
580-5M-25	580	116
600-5M-25	600	120
610-5M-25	610	122
615-5M-25	615	123
630-5M-25	630	126
635-5M-25	635	127
640-5M-25	640	128
645-5M-25	645	129
665-5M-25	665	133

PART NUMBER	PITCH LENGTH (MM)	NO. OF TEETH
1790-5M-15	1790	358
1870-5M-15	1870	374
1895-5M-15	1895	379
2000-5M-15	2000	400
670-5M-25	670	134
700-5M-25	700	140
710-5M-25	710	142
740-5M-25	740	148
750-5M-25	750	150
755-5M-25	755	151
775-5M-25	775	155
790-5M-25	790	158
800-5M-25	800	160
825-5M-25	825	165
835-5M-25	835	167
850-5M-25	850	170
860-5M-25	860	172
890-5M-25	890	178
900-5M-25	900	180
925-5M-25	925	185
935-5M-25	935	187
950-5M-25	950	190
965-5M-25	965	193
980-5M-25	980	196

PART NUMBER	PITCH LENGTH (MM)	NO. OF TEETH
2110-5M-15	2110	422
2350-5M-15	2350	470
2525-5M-15	2525	505
1000-5M-25	1000	200
1035-5M-25	1035	207
1050-5M-25	1050	210
1100-5M-25	1100	220
1125-5M-25	1125	225
1135-5M-25	1135	227
1200-5M-25	1200	240
1270-5M-25	1270	254
1420-5M-25	1420	284
1425-5M-25	1425	285
1500-5M-25	1500	300
1595-5M-25	1595	319
1690-5M-25	1690	338
1790-5M-25	1790	358
1870-5M-25	1870	374
1895-5M-25	1895	379
2000-5M-25	2000	400
2110-5M-25	2110	422
2350-5M-25	2350	470
2525-5M-25	2525	505

**CUT TO SIZE WIDTHS**

If you need a custom width timing belt, OPTIBELT has you covered. Each OPTIBELT facility can cut custom widths. This means you don't have to wait for a manufactured factory order. If it is stocked it can ship!

Contact an OPTIBELT representative regarding additional sizes, stock availability and pricing.

**EXPEDITED SHIPPING:** Each OPTIBELT warehouse facility cuts timing belts to width for faster order service.

**EXAMPLE SIZING:**

Part Number: 294-3M-15

294 = 294 mm Pitch Length 3M = Section Size 15 = 15 mm Belt Width

Part Number: 1062-3M-15

1062 = 1062 mm Pitch Length 3M = Section Size 15 = 15 mm Belt Width



SAMPLE PART # : 880-8M-50

**OMEGA TIMING**

**8M SECTION 8 MM PITCH**

PART NUMBER	PITCH LENGTH (MM)	NO. OF TEETH
320-8M-20	320	40
376-8M-20	376	47
424-8M-20	424	53
480-8M-20	480	60
512-8M-20	512	64
520-8M-20	520	65
560-8M-20	560	70
576-8M-20	576	72
600-8M-20	600	75
608-8M-20	608	76
624-8M-20	624	78
632-8M-20	632	79
640-8M-20	640	80
656-8M-20	656	82
680-8M-20	680	85
712-8M-20	712	89
720-8M-20	720	90
760-8M-20	760	95
776-8M-20	776	97

PART NUMBER	PITCH LENGTH (MM)	NO. OF TEETH
784-8M-20	784	98
800-8M-20	800	100
824-8M-20	824	103
840-8M-20	840	105
848-8M-20	848	106
856-8M-20	856	107
880-8M-20	880	110
896-8M-20	896	112
912-8M-20	912	114
920-8M-20	920	115
960-8M-20	960	120
976-8M-20	976	122
1000-8M-20	1000	125
1040-8M-20	1040	130
1056-8M-20	1056	132
1064-8M-20	1064	133
1080-8M-20	1080	135
1096-8M-20	1096	137
1120-8M-20	1120	140

PART NUMBER	PITCH LENGTH (MM)	NO. OF TEETH
1128-8M-20	1128	141
1160-8M-20	1160	145
1184-8M-20	1184	148
1200-8M-20	1200	150
1216-8M-20	1216	152
1224-8M-20	1224	153
1248-8M-20	1248	156
1256-8M-20	1256	157
1264-8M-20	1264	158
1280-8M-20	1280	160
1304-8M-20	1304	163
1328-8M-20	1328	166
1344-8M-20	1344	168
1360-8M-20	1360	170
1400-8M-20	1400	175
1424-8M-20	1424	178
1432-8M-20	1432	179
1440-8M-20	1440	180
1520-8M-20	1520	190

PART NUMBER	PITCH LENGTH (MM)	NO. OF TEETH
1552-8M-20	1552	194
1600-8M-20	1600	200
1680-8M-20	1680	210
1696-8M-20	1696	212
1728-8M-20	1728	216
1760-8M-20	1760	220
1800-8M-20	1800	225
1904-8M-20	1904	238
1936-8M-20	1936	242
2000-8M-20	2000	250
2080-8M-20	2080	260
2104-8M-20	2104	263
2240-8M-20	2240	280
2248-8M-20	2248	281
2272-8M-20	2272	284
2400-8M-20	2400	300
2504-8M-20	2504	313
2600-8M-20	2600	325
2800-8M-20	2800	350

PART NUMBER	PITCH LENGTH (MM)	NO. OF TEETH
320-8M-30	320	40
376-8M-30	376	47
424-8M-30	424	53
480-8M-30	480	60
512-8M-30	512	64
520-8M-30	520	65
560-8M-30	560	70
576-8M-30	576	72
600-8M-30	600	75
608-8M-30	608	76
624-8M-30	624	78
632-8M-30	632	79
640-8M-30	640	80
656-8M-30	656	82
680-8M-30	680	85
712-8M-30	712	89
720-8M-30	720	90
760-8M-30	760	95
776-8M-30	776	97

PART NUMBER	PITCH LENGTH (MM)	NO. OF TEETH
784-8M-30	784	98
800-8M-30	800	100
824-8M-30	824	103
840-8M-30	840	105
848-8M-30	848	106
856-8M-30	856	107
880-8M-30	880	110
896-8M-30	896	112
912-8M-30	912	114
920-8M-30	920	115
960-8M-30	960	120
976-8M-30	976	122
1000-8M-30	1000	125
1040-8M-30	1040	130
1056-8M-30	1056	132
1064-8M-30	1064	133
1080-8M-30	1080	135
1096-8M-30	1096	137
1120-8M-30	1120	140

PART NUMBER	PITCH LENGTH (MM)	NO. OF TEETH
1128-8M-30	1128	141
1160-8M-30	1160	145
1184-8M-30	1184	148
1200-8M-30	1200	150
1216-8M-30	1216	152
1224-8M-30	1224	153
1248-8M-30	1248	156
1256-8M-30	1256	157
1264-8M-30	1264	158
1280-8M-30	1280	160
1304-8M-30	1304	163
1328-8M-30	1328	166
1344-8M-30	1344	168
1360-8M-30	1360	170
1400-8M-30	1400	175
1424-8M-30	1424	178
1432-8M-30	1432	179
1440-8M-30	1440	180
1520-8M-30	1520	190

PART NUMBER	PITCH LENGTH (MM)	NO. OF TEETH
1552-8M-30	1552	194
1600-8M-30	1600	200
1680-8M-30	1680	210
1696-8M-30	1696	212
1728-8M-30	1728	216
1760-8M-30	1760	220
1800-8M-30	1800	225
1904-8M-30	1904	238
1936-8M-30	1936	242
2000-8M-30	2000	250
2080-8M-30	2080	260
2104-8M-30	2104	263
2240-8M-30	2240	280
2248-8M-30	2248	281
2272-8M-30	2272	284
2400-8M-30	2400	300
2504-8M-30	2504	313
2600-8M-30	2600	325
2800-8M-30	2800	350

8M CONTINUED PG 68

**OMEGA 8M**  
OMEGA TIMING

**EXAMPLE SIZING:**

Part Number: 848-8M-20

848 = 848 mm Pitch Length 8M = Section Size 20 = 20 mm Belt Width

Part Number: 376-8M-30

376 = 376 mm Pitch Length 8M = Section Size 30 = 30 mm Belt Width

Contact an OPTIBELT representative regarding additional sizes, stock availability and pricing.

**EXPEDITED SHIPPING:** Each OPTIBELT warehouse facility cuts timing belts to width for faster order service.



8M SECTION 8 MM PITCH

**OMEGA TIMING**

SAMPLE PART # : 784-8M-85

PART NUMBER	PITCH LENGTH (MM)	NO. OF TEETH
320-8M-50	320	40
376-8M-50	376	47
424-8M-50	424	53
480-8M-50	480	60
512-8M-50	512	64
520-8M-50	520	65
560-8M-50	560	70
576-8M-50	576	72
600-8M-50	600	75
608-8M-50	608	76
624-8M-50	624	78
632-8M-50	632	79
640-8M-50	640	80
656-8M-50	656	82
680-8M-50	680	85
712-8M-50	712	89
720-8M-50	720	90
760-8M-50	760	95
776-8M-50	776	97

PART NUMBER	PITCH LENGTH (MM)	NO. OF TEETH
784-8M-50	784	98
800-8M-50	800	100
824-8M-50	824	103
840-8M-50	840	105
848-8M-50	848	106
856-8M-50	856	107
880-8M-50	880	110
896-8M-50	896	112
912-8M-50	912	114
920-8M-50	920	115
960-8M-50	960	120
976-8M-50	976	122
1000-8M-50	1000	125
1040-8M-50	1040	130
1056-8M-50	1056	132
1064-8M-50	1064	133
1080-8M-50	1080	135
1096-8M-50	1096	137
1120-8M-50	1120	140

PART NUMBER	PITCH LENGTH (MM)	NO. OF TEETH
1128-8M-50	1128	141
1160-8M-50	1160	145
1184-8M-50	1184	148
1200-8M-50	1200	150
1216-8M-50	1216	152
1224-8M-50	1224	153
1248-8M-50	1248	156
1256-8M-50	1256	157
1264-8M-50	1264	158
1280-8M-50	1280	160
1304-8M-50	1304	163
1328-8M-50	1328	166
1344-8M-50	1344	168
1360-8M-50	1360	170
1400-8M-50	1400	175
1424-8M-50	1424	178
1432-8M-50	1432	179
1440-8M-50	1440	180
1520-8M-50	1520	190

PART NUMBER	PITCH LENGTH (MM)	NO. OF TEETH
1552-8M-50	1552	194
1600-8M-50	1600	200
1680-8M-50	1680	210
1696-8M-50	1696	212
1728-8M-50	1728	216
1760-8M-50	1760	220
1800-8M-50	1800	225
1904-8M-50	1904	238
1936-8M-50	1936	242
2000-8M-50	2000	250
2080-8M-50	2080	260
2104-8M-50	2104	263
2240-8M-50	2240	280
2248-8M-50	2248	281
2272-8M-50	2272	284
2400-8M-50	2400	300
2504-8M-50	2504	313
2600-8M-50	2600	325
2800-8M-50	2800	350

PART NUMBER	PITCH LENGTH (MM)	NO. OF TEETH
320-8M-85	320	40
376-8M-85	376	47
424-8M-85	424	53
480-8M-85	480	60
512-8M-85	512	64
520-8M-85	520	65
560-8M-85	560	70
576-8M-85	576	72
600-8M-85	600	75
608-8M-85	608	76
624-8M-85	624	78
632-8M-85	632	79
640-8M-85	640	80
656-8M-85	656	82
680-8M-85	680	85
712-8M-85	712	89
720-8M-85	720	90
760-8M-85	760	95
776-8M-85	776	97

PART NUMBER	PITCH LENGTH (MM)	NO. OF TEETH
784-8M-85	784	98
800-8M-85	800	100
824-8M-85	824	103
840-8M-85	840	105
848-8M-85	848	106
856-8M-85	856	107
880-8M-85	880	110
896-8M-85	896	112
912-8M-85	912	114
920-8M-85	920	115
960-8M-85	960	120
976-8M-85	976	122
1000-8M-85	1000	125
1040-8M-85	1040	130
1056-8M-85	1056	132
1064-8M-85	1064	133
1080-8M-85	1080	135
1096-8M-85	1096	137
1120-8M-85	1120	140

PART NUMBER	PITCH LENGTH (MM)	NO. OF TEETH
1128-8M-85	1128	141
1160-8M-85	1160	145
1184-8M-85	1184	148
1200-8M-85	1200	150
1216-8M-85	1216	152
1224-8M-85	1224	153
1248-8M-85	1248	156
1256-8M-85	1256	157
1264-8M-85	1264	158
1280-8M-85	1280	160
1304-8M-85	1304	163
1328-8M-85	1328	166
1344-8M-85	1344	168
1360-8M-85	1360	170
1400-8M-85	1400	175
1424-8M-85	1424	178
1432-8M-85	1432	179
1440-8M-85	1440	180
1520-8M-85	1520	190

PART NUMBER	PITCH LENGTH (MM)	NO. OF TEETH
1552-8M-85	1552	194
1600-8M-85	1600	200
1680-8M-85	1680	210
1696-8M-85	1696	212
1728-8M-85	1728	216
1760-8M-85	1760	220
1800-8M-85	1800	225
1904-8M-85	1904	238
1936-8M-85	1936	242
2000-8M-85	2000	250
2080-8M-85	2080	260
2104-8M-85	2104	263
2240-8M-85	2240	280
2248-8M-85	2248	281
2272-8M-85	2272	284
2400-8M-85	2400	300
2504-8M-85	2504	313
2600-8M-85	2600	325
2800-8M-85	2800	350

**OMEGA 8M**  
OMEGA TIMING

Contact an OPTIBELT representative regarding additional sizes, stock availability and pricing.

**EXPEDITED SHIPPING:** Each OPTIBELT warehouse facility cuts timing belts to width for faster order service.

**EXAMPLE SIZING:**

Part Number: 1256-8M-50

1256 = 1256 mm Pitch Length 8M = Section Size 50 = 50 mm Belt Width

Part Number: 2080-8M-85

2080 = 2080 mm Pitch Length 8M = Section Size 50 = 50 mm Belt Width



SAMPLE PART # : 1778-14M-115

**OMEGA TIMING**

**14M SECTION 14 MM PITCH**

PART NUMBER	PITCH LENGTH (MM)	NO. OF TEETH	PART NUMBER	PITCH LENGTH (MM)	NO. OF TEETH	PART NUMBER	PITCH LENGTH (MM)	NO. OF TEETH	PART NUMBER	PITCH LENGTH (MM)	NO. OF TEETH
924-14M-40	924	66	1610-14M-40	1610	115	2450-14M-40	2450	175	3850-14M-40	3850	275
966-14M-40	966	69	1778-14M-40	1778	127	2590-14M-40	2590	185	4004-14M-40	4004	286
1092-14M-40	1092	78	1890-14M-40	1890	135	2800-14M-40	2800	200	4326-14M-40	4326	309
1190-14M-40	1190	85	2100-14M-40	2100	150	3150-14M-40	3150	225	4578-14M-40	4578	327
1400-14M-40	1400	100	2310-14M-40	2310	165	3500-14M-40	3500	250			
924-14M-55	924	66	1610-14M-55	1610	115	2450-14M-55	2450	175	3850-14M-55	3850	275
966-14M-55	966	69	1778-14M-55	1778	127	2590-14M-55	2590	185	4004-14M-55	4004	286
1092-14M-55	1092	78	1890-14M-55	1890	135	2800-14M-55	2800	200	4326-14M-55	4326	309
1190-14M-55	1190	85	2100-14M-55	2100	150	3150-14M-55	3150	225	4578-14M-55	4578	327
1400-14M-55	1400	100	2310-14M-55	2310	165	3500-14M-55	3500	250			
924-14M-85	924	66	1610-14M-85	1610	115	2450-14M-85	2450	175	3850-14M-85	3850	275
966-14M-85	966	69	1778-14M-85	1778	127	2590-14M-85	2590	185	4004-14M-85	4004	286
1092-14M-85	1092	78	1890-14M-85	1890	135	2800-14M-85	2800	200	4326-14M-85	4326	309
1190-14M-85	1190	85	2100-14M-85	2100	150	3150-14M-85	3150	225	4578-14M-85	4578	327
1400-14M-85	1400	100	2310-14M-85	2310	165	3500-14M-85	3500	250			
924-14M-115	924	66	1610-14M-115	1610	115	2450-14M-115	2450	175	3850-14M-115	3850	275
966-14M-115	966	69	1778-14M-115	1778	127	2590-14M-115	2590	185	4004-14M-115	4004	286
1092-14M-115	1092	78	1890-14M-115	1890	135	2800-14M-115	2800	200	4326-14M-115	4326	309
1190-14M-115	1190	85	2100-14M-115	2100	150	3150-14M-115	3150	225	4578-14M-115	4578	327
1400-14M-115	1400	100	2310-14M-115	2310	165	3500-14M-115	3500	250			
924-14M-170	924	66	1610-14M-170	1610	115	2450-14M-170	2450	175	3850-14M-170	3850	275
966-14M-170	966	69	1778-14M-170	1778	127	2590-14M-170	2590	185	4004-14M-170	4004	286
1092-14M-170	1092	78	1890-14M-170	1890	135	2800-14M-170	2800	200	4326-14M-170	4326	309
1190-14M-170	1190	85	2100-14M-170	2100	150	3150-14M-170	3150	225	4578-14M-170	4578	327
1400-14M-170	1400	100	2310-14M-170	2310	165	3500-14M-170	3500	250			

**OMEGA, DOUBLE SIDED**

OMEGA double sided belts have the same durability and construction of single sided timing belts.

Contact an OPTIBELT representative regarding additional sizes, availability and pricing.



SECTION	LENGTHS
D3M	SPECIAL ORDER
D5M	1000 – 2525 mm
D8M	1000 – 3280 mm
D14M	SPECIAL ORDER

**OMEGA 14M**  
OMEGA TIMING

**EXAMPLE SIZING:**

Part Number: 1778-14M-40

1778 = 1778 mm Pitch Length 14M = Section Size 40 = 40 mm Belt Width

Part Number: 3850-14M-115

3850 = 3850 mm Pitch Length 14M = Section Size 115 = 115 mm Belt Width

Contact an OPTIBELT representative regarding additional sizes, stock availability and pricing.

**EXPEDITED SHIPPING:** Each OPTIBELT warehouse facility cuts timing belts to width for faster order service.



# optibelt FANPOWER, STD, HTD TIMING BELTS

## 8M SECTION 8 MM PITCH

## FANPOWER TIMING

SAMPLE PART # : 2600-8MFP-50

PART NUMBER	PITCH LENGTH (MM)	NO. OF TEETH	PART NUMBER	PITCH LENGTH (MM)	NO. OF TEETH	PART NUMBER	PITCH LENGTH (MM)	NO. OF TEETH	PART NUMBER	PITCH LENGTH (MM)	NO. OF TEETH
2000-8MFP-30	2000	250	2400-8MFP-30	2400	300	2600-8MFP-30	2600	325	2800-8MFP-30	2800	350
2240-8MFP-30	2240	280									
2000-8MFP-50	2000	250	2400-8MFP-50	2400	300	2600-8MFP-50	2600	325	2800-8MFP-50	2800	350
2240-8MFP-50	2240	280									
2000-8MFP-85	2000	250	2400-8MFP-85	2400	300	2600-8MFP-85	2600	325	2800-8MFP-85	2800	350
2240-8MFP-85	2240	280									

## 14M SECTION 14 MM PITCH

SAMPLE PART # : 2000-8MFP-50

PART NUMBER	PITCH LENGTH (MM)	NO. OF TEETH	PART NUMBER	PITCH LENGTH (MM)	NO. OF TEETH	PART NUMBER	PITCH LENGTH (MM)	NO. OF TEETH	PART NUMBER	PITCH LENGTH (MM)	NO. OF TEETH
3150-14MFP-55	3150	225	3500-14MFP-55	3500	250	4326-14MFP-55	4326	309	4578-14MFP-55	4578	327
3360-14MFP-55	3360	240	3850-14MFP-55	3850	275						
3150-14MFP-85	3150	225	3500-14MFP-85	3500	250	4326-14MFP-85	4326	309	4578-14MFP-85	4578	327
3360-14MFP-85	3360	240	3850-14MFP-85	3850	275						

## STD TIMING

Optibelt STD® timing belts have semi-circular teeth for superior shear strength. The timing belt tooth geometry combined with the belt structure leads to even load distribution and optimized engagement of the toothed pulleys.

Available in HP or HL constructions; single and double sided profiles. Contact an OPTIBELT representative regarding additional sizes, availability and pricing.

### In-stock inventory available.

Contact an OPTIBELT representative for details.

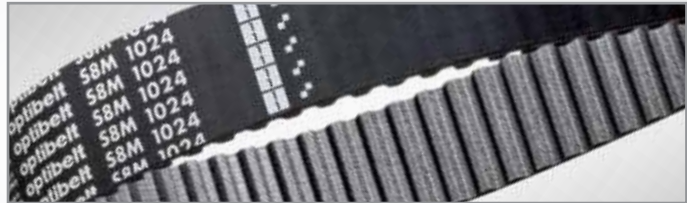

SECTION	LENGTHS
S3M	120 – 633 mm
S5M	255 – 2000 mm
S8M	440 – 3200 mm
S14M	1400 – 5012 mm

## HTD TIMING

The optibelt HTD- timing belts have curvilinear tooth profile for greater tooth shear resistance. The tooth profile and construction produces evenly distributes high loads.

The benefits of the optibelt HTD timing belts make them suitable for industrial drives, in particular low speed - high torque applications.

Available in single and double sided profiles. Contact an OPTIBELT representative regarding additional sizes, availability and pricing.

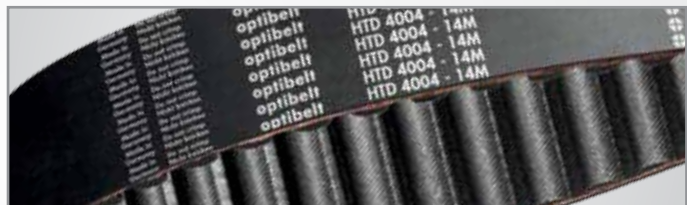

SECTION	LENGTHS
3M	111 – 6600 mm
5M	111 – 6600 mm
8M	111 – 6600 mm
14M	111 – 6600 mm
20M	2000 – 6600 mm

Contact an OPTIBELT representative regarding additional sizes, stock availability and pricing.

**EXPEDITED SHIPPING:** Each OPTIBELT warehouse facility cuts timing belts to width for faster order service.

### EXAMPLE SIZING:

Part Number: 2400-8MFP-30 (FP=FANPOWER)  
 2400 = 2400 mm Pitch Length 8M = Section Size 30 = 30 mm Belt Width  
 Part Number: 3150-14MFP-85 (FP=FANPOWER)  
 3150 = 3150 mm Pitch Length 14M = Section Size 85 = 85 mm Belt Width





SAMPLE PART # : 2520MXL012

**ZR TIMING**

MXL SECTION .080 IN. PITCH

PART NUMBER	PITCH LENGTH (IN)	NO. OF TEETH	PART NUMBER	PITCH LENGTH (IN)	NO. OF TEETH	PART NUMBER	PITCH LENGTH (IN)	NO. OF TEETH	PART NUMBER	PITCH LENGTH (IN)	NO. OF TEETH
264MXL012	2.64	33	704MXL012	7.04	88	1040MXL012	10.4	130	1888MXL012	18.88	236
360MXL012	3.6	45	728MXL012	7.28	91	1056MXL012	10.56	132	1984MXL012	19.84	248
432MXL012	4.32	54	736MXL012	7.36	92	1072MXL012	10.72	134	1992MXL012	19.92	249
440MXL012	4.4	55	752MXL012	7.52	94	1112MXL012	11.12	139	2048MXL012	20.48	256
448MXL012	4.48	56	760MXL012	7.6	95	1120MXL012	11.2	140	2144MXL012	21.44	268
456MXL012	4.56	57	776MXL012	7.76	97	1136MXL012	11.36	142	2240MXL012	22.4	280
464MXL012	4.64	58	800MXL012	8	100	1176MXL012	11.76	147	2384MXL012	23.84	298
480MXL012	4.8	60	808MXL012	8.08	101	1184MXL012	11.84	148	2480MXL012	24.8	310
488MXL012	4.88	61	816MXL012	8.16	102	1200MXL012	12	150	2520MXL012	25.2	315
536MXL012	5.36	67	824MXL012	8.24	103	1224MXL012	12.24	153	2680MXL012	26.8	335
544MXL012	5.44	68	840MXL012	8.4	105	1272MXL012	12.72	159	2776MXL012	27.76	347
568MXL012	5.68	71	856MXL012	8.56	107	1280MXL012	12.8	160	2880MXL012	28.8	360
576MXL012	5.76	72	864MXL012	8.64	108	1320MXL012	13.2	165	2920MXL012	29.2	365
600MXL012	6	75	912MXL012	9.12	114	1400MXL012	14	175	3200MXL012	32	400
632MXL012	6.32	79	920MXL012	9.2	115	1472MXL012	14.72	184	3472MXL012	34.72	434
640MXL012	6.4	80	960MXL012	9.6	120	1520MXL012	15.2	190	3624MXL012	36.24	453
656MXL012	6.56	82	984MXL012	9.84	123	1560MXL012	15.6	195	3704MXL012	37.04	463
672MXL012	6.72	84	1000MXL012	10	125	1600MXL012	16	200	3784MXL012	37.84	473
680MXL012	6.8	85	1008MXL012	10.08	126	1768MXL012	17.68	221	4040MXL012	40.4	505
264MXL019	2.64	33	704MXL019	7.04	88	1040MXL019	10.4	130	1888MXL019	18.88	236
360MXL019	3.6	45	728MXL019	7.28	91	1056MXL019	10.56	132	1984MXL019	19.84	248
432MXL019	4.32	54	736MXL019	7.36	92	1072MXL019	10.72	134	1992MXL019	19.92	249
440MXL019	4.4	55	752MXL019	7.52	94	1112MXL019	11.12	139	2048MXL019	20.48	256
448MXL019	4.48	56	760MXL019	7.6	95	1120MXL019	11.2	140	2144MXL019	21.44	268
456MXL019	4.56	57	776MXL019	7.76	97	1136MXL019	11.36	142	2240MXL019	22.4	280
464MXL019	4.64	58	800MXL019	8	100	1176MXL019	11.76	147	2384MXL019	23.84	298
480MXL019	4.8	60	808MXL019	8.08	101	1184MXL019	11.84	148	2480MXL019	24.8	310
488MXL019	4.88	61	816MXL019	8.16	102	1200MXL019	12	150	2520MXL019	25.2	315
536MXL019	5.36	67	824MXL019	8.24	103	1224MXL019	12.24	153	2680MXL019	26.8	335
544MXL019	5.44	68	840MXL019	8.4	105	1272MXL019	12.72	159	2776MXL019	27.76	347
568MXL019	5.68	71	856MXL019	8.56	107	1280MXL019	12.8	160	2880MXL019	28.8	360
576MXL019	5.76	72	864MXL019	8.64	108	1320MXL019	13.2	165	2920MXL019	29.2	365
600MXL019	6	75	912MXL019	9.12	114	1400MXL019	14	175	3200MXL019	32	400
632MXL019	6.32	79	920MXL019	9.2	115	1472MXL019	14.72	184	3472MXL019	34.72	434
640MXL019	6.4	80	960MXL019	9.6	120	1520MXL019	15.2	190	3624MXL019	36.24	453
656MXL019	6.56	82	984MXL019	9.84	123	1560MXL019	15.6	195	3704MXL019	37.04	463
672MXL019	6.72	84	1000MXL019	10	125	1600MXL019	16	200	3784MXL019	37.84	473
680MXL019	6.8	85	1008MXL019	10.08	126	1768MXL019	17.68	221	4040MXL019	40.4	505

**MXL CONTINUED PG 71**

**ZR MXL**  
ZR TIMING

**EXAMPLE SIZING:**

Part Number: 864MXL012

864 = 8.64 in. Pitch Length MXL = Section Size Q12 = .12 in. Belt Width

Part Number: 1280MXL019

1280 = 12.8 in. Pitch Length MXL = Section Size Q19 = .19 in. Belt Width

Contact an OPTIBELT representative regarding additional sizes, stock availability and pricing.

**EXPEDITED SHIPPING:** Each OPTIBELT warehouse facility cuts timing belts to width for faster order service.



MXL SECTION .080 IN. PITCH

**ZR TIMING**

SAMPLE PART # : 1184MXL025

PART NUMBER	PITCH LENGTH (IN)	NO. OF TEETH	PART NUMBER	PITCH LENGTH (IN)	NO. OF TEETH	PART NUMBER	PITCH LENGTH (IN)	NO. OF TEETH	PART NUMBER	PITCH LENGTH (IN)	NO. OF TEETH
264MXL025	2.64	33	704MXL025	7.04	88	1040MXL025	10.4	130	1888MXL025	18.88	236
360MXL025	3.60	45	728MXL025	7.28	91	1056MXL025	10.56	132	1984MXL025	19.84	248
432MXL025	4.32	54	736MXL025	7.36	92	1072MXL025	10.72	134	1992MXL025	19.92	249
440MXL025	4.40	55	752MXL025	7.52	94	1112MXL025	11.12	139	2048MXL025	20.48	256
448MXL025	4.48	56	760MXL025	7.60	95	1120MXL025	11.2	140	2144MXL025	21.44	268
456MXL025	4.56	57	776MXL025	7.76	97	1136MXL025	11.36	142	2240MXL025	22.4	280
464MXL025	4.64	58	800MXL025	8.00	100	1176MXL025	11.76	147	2384MXL025	23.84	298
480MXL025	4.80	60	808MXL025	8.08	101	1184MXL025	11.84	148	2480MXL025	24.8	310
488MXL025	4.88	61	816MXL025	8.16	102	1200MXL025	12	150	2520MXL025	25.2	315
536MXL025	5.36	67	824MXL025	8.24	103	1224MXL025	12.24	153	2680MXL025	26.8	335
544MXL025	5.44	68	840MXL025	8.40	105	1272MXL025	12.72	159	2776MXL025	27.76	347
568MXL025	5.68	71	856MXL025	8.56	107	1280MXL025	12.8	160	2880MXL025	28.8	360
576MXL025	5.76	72	864MXL025	8.64	108	1320MXL025	13.2	165	2920MXL025	29.2	365
600MXL025	6.00	75	912MXL025	9.12	114	1400MXL025	14	175	3200MXL025	32	400
632MXL025	6.32	79	920MXL025	9.20	115	1472MXL025	14.72	184	3472MXL025	34.72	434
640MXL025	6.40	80	960MXL025	9.60	120	1520MXL025	15.2	190	3624MXL025	36.24	453
656MXL025	6.56	82	984MXL025	9.84	123	1560MXL025	15.6	195	3704MXL025	37.04	463
672MXL025	6.72	84	1000MXL025	10.00	125	1600MXL025	16	200	3784MXL025	37.84	473
680MXL025	6.80	85	1008MXL025	10.08	126	1768MXL025	17.68	221	4040MXL025	40.4	505

Contact an OPTIBELT representative regarding additional sizes, stock availability and pricing.

**EXPEDITED SHIPPING:** Each OPTIBELT warehouse facility cuts timing belts to width for faster order service.

**EXAMPLE SIZING:**

Part Number: 736MXL025

736 = 7.36 in. Pitch Length    MXL = Section Size    025 = .25 in. Belt Width

Part Number: 1600MXL025

1600 = 16 in. Pitch Length    MXL = Section Size    025 = .25 in. Belt Width



SAMPLE PART # : 168XL031

**ZR TIMING**

XL SECTION .200 IN. PITCH

PART NUMBER	PITCH LENGTH (IN)	NO. OF TEETH	PART NUMBER	PITCH LENGTH (IN)	NO. OF TEETH	PART NUMBER	PITCH LENGTH (IN)	NO. OF TEETH	PART NUMBER	PITCH LENGTH (IN)	NO. OF TEETH
60XL025	6	30	134XL025	13.4	67	196XL025	19.6	98	322XL025	32.2	161
70XL025	7	35	136XL025	13.6	68	200XL025	20	100	330XL025	33	165
80XL025	8	40	138XL025	13.8	69	210XL025	21	105	340XL025	34	170
86XL025	8.6	43	140XL025	14	70	220XL025	22	110	344XL025	34.4	172
88XL025	8.8	44	142XL025	14.2	71	230XL025	23	115	350XL025	35	175
90XL025	9	45	148XL025	14.8	74	240XL025	24	120	360XL025	36	180
92XL025	9.2	46	150XL025	15	75	244XL025	24.4	122	380XL025	38	190
94XL025	9.4	47	156XL025	15.6	78	248XL025	24.8	124	382XL025	38.2	191
96XL025	9.6	48	160XL025	16	80	250XL025	25	125	388XL025	38.8	194
98XL025	9.8	49	162XL025	16.2	81	260XL025	26	130	390XL025	39	195
100XL025	10	50	166XL025	16.6	83	270XL025	27	135	392XL025	39.2	196
102XL025	10.2	51	168XL025	16.8	84	272XL025	27.2	136	412XL025	41.2	206
106XL025	10.6	53	170XL025	17	85	274XL025	27.4	137	414XL025	41.4	207
108XL025	10.8	54	174XL025	17.4	87	280XL025	28	140	432XL025	43.2	216
110XL025	11	55	176XL025	17.6	88	286XL025	28.6	143	434XL025	43.4	217
112XL025	11.2	56	178XL025	17.8	89	290XL025	29	145	438XL025	43.8	219
116XL025	11.6	58	180XL025	18	90	296XL025	29.6	148	460XL025	46	230
118XL025	11.8	59	182XL025	18.2	91	300XL025	30	150	498XL025	49.8	249
120XL025	12	60	184XL025	18.4	92	306XL025	30.6	153	506XL025	50.6	253
124XL025	12.4	62	188XL025	18.8	94	310XL025	31	155	514XL025	51.4	257
126XL025	12.6	63	190XL025	19	95	316XL025	31.6	158	580XL025	58	290
128XL025	12.8	64	192XL025	19.2	96	320XL025	32	160	630XL025	63	315
130XL025	13	65	194XL025	19.4	97						
60XL031	6	30	116XL031	11.6	58	162XL031	16.2	81	210XL031	21	105
70XL031	7	35	118XL031	11.8	59	166XL031	16.6	83	220XL031	22	110
80XL031	8	40	120XL031	12	60	168XL031	16.8	84	230XL031	23	115
86XL031	8.6	43	124XL031	12.4	62	170XL031	17	85	240XL031	24	120
88XL031	8.8	44	126XL031	12.6	63	174XL031	17.4	87	244XL031	24.4	122
90XL031	9	45	128XL031	12.8	64	176XL031	17.6	88	248XL031	24.8	124
92XL031	9.2	46	130XL031	13	65	178XL031	17.8	89	250XL031	25	125
94XL031	9.4	47	134XL031	13.4	67	180XL031	18	90	260XL031	26	130
96XL031	9.6	48	136XL031	13.6	68	182XL031	18.2	91	270XL031	27	135
98XL031	9.8	49	138XL031	13.8	69	184XL031	18.4	92	272XL031	27.2	136
100XL031	10	50	140XL031	14	70	188XL031	18.8	94	274XL031	27.4	137
102XL031	10.2	51	142XL031	14.2	71	190XL031	19	95	280XL031	28	140
106XL031	10.6	53	148XL031	14.8	74	192XL031	19.2	96	286XL031	28.6	143
108XL031	10.8	54	150XL031	15	75	194XL031	19.4	97	290XL031	29	145
110XL031	11	55	156XL031	15.6	78	196XL031	19.6	98			
112XL031	11.2	56	160XL031	16	80	200XL031	20	100			

**XL031 CONTINUED PG 74**

**EXAMPLE SIZING:**

Part Number: 286XL025

286 = 28.6 in. Pitch Length XL = Section Size Q25 = .25 in. Belt Width

Part Number: 136XL031

136 = 13.6 in. Pitch Length XL = Section Size Q31 = .31 in. Belt Width

Contact an OPTIBELT representative regarding additional sizes, stock availability and pricing.

**EXPEDITED SHIPPING:** Each OPTIBELT warehouse facility cuts timing belts to width for faster order service.



XL SECTION .200 IN. PITCH

**ZR TIMING**

SAMPLE PART # : 240XL037

PART NUMBER	PITCH LENGTH (IN)	NO. OF TEETH	PART NUMBER	PITCH LENGTH (IN)	NO. OF TEETH	PART NUMBER	PITCH LENGTH (IN)	NO. OF TEETH	PART NUMBER	PITCH LENGTH (IN)	NO. OF TEETH
296XL031	29.6	148	330XL031	33	165	388XL031	38.8	194	438XL031	43.8	219
300XL031	30	150	340XL031	34	170	390XL031	39	195	460XL031	46	230
306XL031	30.6	153	344XL031	34.4	172	392XL031	39.2	196	498XL031	49.8	249
310XL031	31	155	350XL031	35	175	412XL031	41.2	206	506XL031	50.6	253
316XL031	31.6	158	360XL031	36	180	414XL031	41.4	207	514XL031	51.4	257
320XL031	32	160	380XL031	38	190	432XL031	43.2	216	580XL031	58	290
322XL031	32.2	161	382XL031	38.2	191	434XL031	43.4	217	630XL031	63	315
60XL037	6	30	134XL037	13.4	67	196XL037	19.6	98	322XL037	32.2	161
70XL037	7	35	136XL037	13.6	68	200XL037	20	100	330XL037	33	165
80XL037	8	40	138XL037	13.8	69	210XL037	21	105	340XL037	34	170
86XL037	8.6	43	140XL037	14	70	220XL037	22	110	344XL037	34.4	172
88XL037	8.8	44	142XL037	14.2	71	230XL037	23	115	350XL037	35	175
90XL037	9	45	148XL037	14.8	74	240XL037	24	120	360XL037	36	180
92XL037	9.2	46	150XL037	15	75	244XL037	24.4	122	380XL037	38	190
94XL037	9.4	47	156XL037	15.6	78	248XL037	24.8	124	382XL037	38.2	191
96XL037	9.6	48	160XL037	16	80	250XL037	25	125	388XL037	38.8	194
98XL037	9.8	49	162XL037	16.2	81	260XL037	26	130	390XL037	39	195
100XL037	10	50	166XL037	16.6	83	270XL037	27	135	392XL037	39.2	196
102XL037	10.2	51	168XL037	16.8	84	272XL037	27.2	136	412XL037	41.2	206
106XL037	10.6	53	170XL037	17	85	274XL037	27.4	137	414XL037	41.4	207
108XL037	10.8	54	174XL037	17.4	87	280XL037	28	140	432XL037	43.2	216
110XL037	11	55	176XL037	17.6	88	286XL037	28.6	143	434XL037	43.4	217
112XL037	11.2	56	178XL037	17.8	89	290XL037	29	145	438XL037	43.8	219
116XL037	11.6	58	180XL037	18	90	296XL037	29.6	148	460XL037	46	230
118XL037	11.8	59	182XL037	18.2	91	300XL037	30	150	498XL037	49.8	249
120XL037	12	60	184XL037	18.4	92	306XL037	30.6	153	506XL037	50.6	253
124XL037	12.4	62	188XL037	18.8	94	310XL037	31	155	514XL037	51.4	257
126XL037	12.6	63	190XL037	19	95	316XL037	31.6	158	580XL037	58	290
128XL037	12.8	64	192XL037	19.2	96	320XL037	32	160	630XL037	63	315
130XL037	13	65	194XL037	19.4	97						
60XL050	6	30	98XL050	9.8	49	120XL050	12	60	142XL050	14.2	71
70XL050	7	35	100XL050	10	50	124XL050	12.4	62	148XL050	14.8	74
80XL050	8	40	102XL050	10.2	51	126XL050	12.6	63	150XL050	15	75
86XL050	8.6	43	106XL050	10.6	53	128XL050	12.8	64	156XL050	15.6	78
88XL050	8.8	44	108XL050	10.8	54	130XL050	13	65	160XL050	16	80
90XL050	9	45	110XL050	11	55	134XL050	13.4	67	162XL050	16.2	81
92XL050	9.2	46	112XL050	11.2	56	136XL050	13.6	68	166XL050	16.6	83
94XL050	9.4	47	116XL050	11.6	58	138XL050	13.8	69			
96XL050	9.6	48	118XL050	11.8	59	140XL050	14	70			

**XL050 CONTINUED PG 75**

ZR XL  
ZR TIMING

Contact an OPTIBELT representative regarding additional sizes, stock availability and pricing.

**EXPEDITED SHIPPING:** Each OPTIBELT warehouse facility cuts timing belts to width for faster order service.

**EXAMPLE SIZING:**

Part Number: 380XL037

380 = 38 in. Pitch Length XL = Section Size 037 = .37 in. Belt Width

Part Number: 100XL050

100 = 10 in. Pitch Length XL = Section Size 050 = .5 in. Belt Width



SAMPLE PART # : 192XL050

**ZR TIMING**

XL SECTION .200 IN. PITCH

PART NUMBER	PITCH LENGTH (IN)	NO. OF TEETH	PART NUMBER	PITCH LENGTH (IN)	NO. OF TEETH	PART NUMBER	PITCH LENGTH (IN)	NO. OF TEETH	PART NUMBER	PITCH LENGTH (IN)	NO. OF TEETH
168XL050	16.8	84	210XL050	21	105	296XL050	29.6	148	388XL050	38.8	194
170XL050	17	85	220XL050	22	110	300XL050	30	150	390XL050	39	195
174XL050	17.4	87	230XL050	23	115	306XL050	30.6	153	392XL050	39.2	196
176XL050	17.6	88	240XL050	24	120	310XL050	31	155	412XL050	41.2	206
178XL050	17.8	89	244XL050	24.4	122	316XL050	31.6	158	414XL050	41.4	207
180XL050	18	90	248XL050	24.8	124	320XL050	32	160	432XL050	43.2	216
182XL050	18.2	91	250XL050	25	125	322XL050	32.2	161	434XL050	43.4	217
184XL050	18.4	92	260XL050	26	130	330XL050	33	165	438XL050	43.8	219
188XL050	18.8	94	270XL050	27	135	340XL050	34	170	460XL050	46	230
190XL050	19	95	272XL050	27.2	136	344XL050	34.4	172	498XL050	49.8	249
192XL050	19.2	96	274XL050	27.4	137	350XL050	35	175	506XL050	50.6	253
194XL050	19.4	97	280XL050	28	140	360XL050	36	180	514XL050	51.4	257
196XL050	19.6	98	286XL050	28.6	143	380XL050	38	190	580XL050	58	290
200XL050	20	100	290XL050	29	145	382XL050	38.2	191	630XL050	63	315
60XL075	6	30	134XL075	13.4	67	196XL075	19.6	98	330XL075	33	165
70XL075	7	35	136XL075	13.6	68	200XL075	20	100	340XL075	34	170
80XL075	8	40	138XL075	13.8	69	210XL075	21	105	344XL075	34.4	172
86XL075	8.6	43	140XL075	14	70	220XL075	22	110	350XL075	35	175
88XL075	8.8	44	142XL075	14.2	71	230XL075	23	115	360XL075	36	180
90XL075	9	45	148XL075	14.8	74	240XL075	24	120	380XL075	38	190
92XL075	9.2	46	150XL075	15	75	244XL075	24.4	122	382XL075	38.2	191
94XL075	9.4	47	156XL075	15.6	78	248XL075	24.8	124	388XL075	38.8	194
96XL075	9.6	48	160XL075	16	80	250XL075	25	125	390XL075	39	195
98XL075	9.8	49	162XL075	16.2	81	260XL075	26	130	392XL075	39.2	196
100XL075	10	50	166XL075	16.6	83	270XL075	27	135	412XL075	41.2	206
102XL075	10.2	51	168XL075	16.8	84	272XL075	27.2	136	414XL075	41.4	207
106XL075	10.6	53	170XL075	17	85	274XL075	27.4	137	432XL075	43.2	216
108XL075	10.8	54	174XL075	17.4	87	280XL075	28	140	434XL075	43.4	217
110XL075	11	55	176XL075	17.6	88	286XL075	28.6	143	438XL075	43.8	219
112XL075	11.2	56	178XL075	17.8	89	290XL075	29	145	460XL075	46	230
116XL075	11.6	58	180XL075	18	90	296XL075	29.6	148	498XL075	49.8	249
118XL075	11.8	59	182XL075	18.2	91	300XL075	30	150	506XL075	50.6	253
120XL075	12	60	184XL075	18.4	92	306XL075	30.6	153	514XL075	51.4	257
124XL075	12.4	62	188XL075	18.8	94	310XL075	31	155	580XL075	58	290
126XL075	12.6	63	190XL075	19	95	316XL075	31.6	158	630XL075	63	315
128XL075	12.8	64	192XL075	19.2	96	320XL075	32	160			
130XL075	13	65	194XL075	19.4	97	322XL075	32.2	161			

**XL CONTINUED PG 76**

**EXAMPLE SIZING:**

Part Number: 176XL050

176 = 17.6 in. Pitch Length XL = Section Size Q50 = .5 in. Belt Width

Part Number: 390XL075

390 = 39 in. Pitch Length XL = Section Size Q75 = .75 in. Belt Width

Contact an OPTIBELT representative regarding additional sizes, stock availability and pricing.

**EXPEDITED SHIPPING:** Each OPTIBELT warehouse facility cuts timing belts to width for faster order service.



XL SECTION .200 IN. PITCH

**ZR TIMING**

SAMPLE PART # : 240XL037

PART NUMBER	PITCH LENGTH (IN)	NO. OF TEETH	PART NUMBER	PITCH LENGTH (IN)	NO. OF TEETH	PART NUMBER	PITCH LENGTH (IN)	NO. OF TEETH	PART NUMBER	PITCH LENGTH (IN)	NO. OF TEETH
60XL100	6	30	134XL100	13.4	67	196XL100	19.6	98	322XL100	32.2	161
70XL100	7	35	136XL100	13.6	68	200XL100	20	100	330XL100	33	165
80XL100	8	40	138XL100	13.8	69	210XL100	21	105	340XL100	34	170
86XL100	8.6	43	140XL100	14	70	220XL100	22	110	344XL100	34.4	172
88XL100	8.8	44	142XL100	14.2	71	230XL100	23	115	350XL100	35	175
90XL100	9	45	148XL100	14.8	74	240XL100	24	120	360XL100	36	180
92XL100	9.2	46	150XL100	15	75	244XL100	24.4	122	380XL100	38	190
94XL100	9.4	47	156XL100	15.6	78	248XL100	24.8	124	382XL100	38.2	191
96XL100	9.6	48	160XL100	16	80	250XL100	25	125	388XL100	38.8	194
98XL100	9.8	49	162XL100	16.2	81	260XL100	26	130	390XL100	39	195
100XL100	10	50	166XL100	16.6	83	270XL100	27	135	392XL100	39.2	196
102XL100	10.2	51	168XL100	16.8	84	272XL100	27.2	136	412XL100	41.2	206
106XL100	10.6	53	170XL100	17	85	274XL100	27.4	137	414XL100	41.4	207
108XL100	10.8	54	174XL100	17.4	87	280XL100	28	140	432XL100	43.2	216
110XL100	11	55	176XL100	17.6	88	286XL100	28.6	143	434XL100	43.4	217
112XL100	11.2	56	178XL100	17.8	89	290XL100	29	145	438XL100	43.8	219
116XL100	11.6	58	180XL100	18	90	296XL100	29.6	148	460XL100	46	230
118XL100	11.8	59	182XL100	18.2	91	300XL100	30	150	498XL100	49.8	249
120XL100	12	60	184XL100	18.4	92	306XL100	30.6	153	506XL100	50.6	253
124XL100	12.4	62	188XL100	18.8	94	310XL100	31	155	514XL100	51.4	257
126XL100	12.6	63	190XL100	19	95	316XL100	31.6	158	580XL100	58	290
128XL100	12.8	64	192XL100	19.2	96	320XL100	32	160	630XL100	63	315
130XL100	13	65	194XL100	19.4	97						

**CUT TO SIZE WIDTHS**

If you need a custom width timing belt, OPTIBELT has you covered. Each OPTIBELT facility can cut custom widths. This means you don't have to wait for a manufactured factory order. If it is stocked it can ship!

Contact an OPTIBELT representative regarding additional sizes, stock availability and pricing.

**EXPEDITED SHIPPING:** Each OPTIBELT warehouse facility cuts timing belts to width for faster order service.

**EXAMPLE SIZING:**

Part Number: 180XL100

180 = 18 in. Pitch Length XL = Section Size 100 = 1 in. Belt Width

Part Number: 506XL100

506 = 50.6 in. Pitch Length XL = Section Size 100 = 1 in. Belt Width



SAMPLE PART # : 510L075

**ZR TIMING**

L SECTION .375 IN. PITCH

PART NUMBER	PITCH LENGTH (IN)	NO. OF TEETH	PART NUMBER	PITCH LENGTH (IN)	NO. OF TEETH	PART NUMBER	PITCH LENGTH (IN)	NO. OF TEETH	PART NUMBER	PITCH LENGTH (IN)	NO. OF TEETH
109L050	10.9	29	236L050	23.6	63	360L050	36	96	450L050	45	120
124L050	12.4	33	240L050	24	64	367L050	36.7	98	454L050	45.4	121
150L050	15	40	255L050	25.5	68	375L050	37.5	100	480L050	48	128
165L050	16.5	44	259L050	25.9	69	390L050	39	104	510L050	51	136
169L050	16.9	45	263L050	26.3	70	405L050	40.5	108	525L050	52.5	140
173L050	17.3	46	270L050	27	72	420L050	42	112	540L050	54	144
187L050	18.7	50	285L050	28.5	76	424L050	42.4	113	600L050	60	160
202L050	20.2	54	300L050	30	80	427L050	42.7	114	630L050	63	168
210L050	21	56	322L050	32.2	86	435L050	43.5	116	660L050	66	176
225L050	22.5	60	345L050	34.5	92	439L050	43.9	117	817L050	81.7	218
232L050	23.2	62									

109L075	10.9	29	236L075	23.6	63	360L075	36	96	450L075	45	120
124L075	12.4	33	240L075	24	64	367L075	36.7	98	454L075	45.4	121
150L075	15	40	255L075	25.5	68	375L075	37.5	100	480L075	48	128
165L075	16.5	44	259L075	25.9	69	390L075	39	104	510L075	51	136
169L075	16.9	45	263L075	26.3	70	405L075	40.5	108	525L075	52.5	140
173L075	17.3	46	270L075	27	72	420L075	42	112	540L075	54	144
187L075	18.7	50	285L075	28.5	76	424L075	42.4	113	600L075	60	160
202L075	20.2	54	300L075	30	80	427L075	42.7	114	630L075	63	168
210L075	21	56	322L075	32.2	86	435L075	43.5	116	660L075	66	176
225L075	22.5	60	345L075	34.5	92	439L075	43.9	117	817L075	81.7	218
232L075	23.2	62									

109L100	10.9	29	236L100	23.6	63	360L100	36	96	450L100	45	120
124L100	12.4	33	240L100	24	64	367L100	36.7	98	454L100	45.4	121
150L100	15	40	255L100	25.5	68	375L100	37.5	100	480L100	48	128
165L100	16.5	44	259L100	25.9	69	390L100	39	104	510L100	51	136
169L100	16.9	45	263L100	26.3	70	405L100	40.5	108	525L100	52.5	140
173L100	17.3	46	270L100	27	72	420L100	42	112	540L100	54	144
187L100	18.7	50	285L100	28.5	76	424L100	42.4	113	600L100	60	160
202L100	20.2	54	300L100	30	80	427L100	42.7	114	630L100	63	168
210L100	21	56	322L100	32.2	86	435L100	43.5	116	660L100	66	176
225L100	22.5	60	345L100	34.5	92	439L100	43.9	117	817L100	81.7	218
232L100	23.2	62									

**L CONTINUED PG 78**

**CUT TO SIZE WIDTHS**

If you need a custom width timing belt, OPTIBELT has you covered. Each OPTIBELT facility can cut custom widths. This means you don't have to wait for a manufactured factory order. If it is stocked it can ship!

**EXAMPLE SIZING:**

Part Number: 236L075  
 236 = 23.6 in. Pitch Length L = Section Size 075 = .75 in. Belt Width  
 Part Number: 480L100  
 480 = 48 in. Pitch Length L = Section Size 100 = 1 in. Belt Width

Contact an OPTIBELT representative regarding additional sizes, stock availability and pricing.

**EXPEDITED SHIPPING:** Each OPTIBELT warehouse facility cuts timing belts to width for faster order service.



L SECTION .375 IN. PITCH

**ZR TIMING**

SAMPLE PART # : 270L150

PART NUMBER	PITCH LENGTH (IN)	NO. OF TEETH	PART NUMBER	PITCH LENGTH (IN)	NO. OF TEETH	PART NUMBER	PITCH LENGTH (IN)	NO. OF TEETH	PART NUMBER	PITCH LENGTH (IN)	NO. OF TEETH
109L150	10.9	29	236L150	23.6	63	360L150	36	96	450L150	45	120
124L150	12.4	33	240L150	24	64	367L150	36.7	98	454L150	45.4	121
150L150	15	40	255L150	25.5	68	375L150	37.5	100	480L150	48	128
165L150	16.5	44	259L150	25.9	69	390L150	39	104	510L150	51	136
169L150	16.9	45	263L150	26.3	70	405L150	40.5	108	525L150	52.5	140
173L150	17.3	46	270L150	27	72	420L150	42	112	540L150	54	144
187L150	18.7	50	285L150	28.5	76	424L150	42.4	113	600L150	60	160
202L150	20.2	54	300L150	30	80	427L150	42.7	114	630L150	63	168
210L150	21	56	322L150	32.2	86	435L150	43.5	116	660L150	66	176
225L150	22.5	60	345L150	34.5	92	439L150	43.9	117	817L150	81.7	218
232L150	23.2	62									
109L200	10.9	29	236L200	23.6	63	360L200	36	96	450L200	45	120
124L200	12.4	33	240L200	24	64	367L200	36.7	98	454L200	45.4	121
150L200	15	40	255L200	25.5	68	375L200	37.5	100	480L200	48	128
165L200	16.5	44	259L200	25.9	69	390L200	39	104	510L200	51	136
169L200	16.9	45	263L200	26.3	70	405L200	40.5	108	525L200	52.5	140
173L200	17.3	46	270L200	27	72	420L200	42	112	540L200	54	144
187L200	18.7	50	285L200	28.5	76	424L200	42.4	113	600L200	60	160
202L200	20.2	54	300L200	30	80	427L200	42.7	114	630L200	63	168
210L200	21	56	322L200	32.2	86	435L200	43.5	116	660L200	66	176
225L200	22.5	60	345L200	34.5	92	439L200	43.9	117	817L200	81.7	218
232L200	23.2	62									
109L300	10.9	29	236L300	23.6	63	360L300	36	96	450L300	45	120
124L300	12.4	33	240L300	24	64	367L300	36.7	98	454L300	45.4	121
150L300	15	40	255L300	25.5	68	375L300	37.5	100	480L300	48	128
165L300	16.5	44	259L300	25.9	69	390L300	39	104	510L300	51	136
169L300	16.9	45	263L300	26.3	70	405L300	40.5	108	525L300	52.5	140
173L300	17.3	46	270L300	27	72	420L300	42	112	540L300	54	144
187L300	18.7	50	285L300	28.5	76	424L300	42.4	113	600L300	60	160
202L300	20.2	54	300L300	30	80	427L300	42.7	114	630L300	63	168
210L300	21	56	322L300	32.2	86	435L300	43.5	116	660L300	66	176
225L300	22.5	60	345L300	34.5	92	439L300	43.9	117	817L300	81.7	218
232L300	23.2	62									

**CUT TO SIZE WIDTHS**

If you need a custom width timing belt, OPTIBELT has you covered. Each OPTIBELT facility can cut custom widths. This means you don't have to wait for a manufactured factory order. If it is stocked it can ship!

Contact an OPTIBELT representative regarding additional sizes, stock availability and pricing.

**EXPEDITED SHIPPING:** Each OPTIBELT warehouse facility cuts timing belts to width for faster order service.

**EXAMPLE SIZING:**

Part Number: 270L150

270 = 27 in. Pitch Length L = Section Size 150 = 1.5 in. Belt Width

Part Number: 150L300

150 = 15 in. Pitch Length L = Section Size 300 = 3 in. Belt Width





SAMPLE PART # : 410H100

**ZR TIMING**

H SECTION .500 IN. PITCH

PART NUMBER	PITCH LENGTH (IN)	NO. OF TEETH	PART NUMBER	PITCH LENGTH (IN)	NO. OF TEETH	PART NUMBER	PITCH LENGTH (IN)	NO. OF TEETH	PART NUMBER	PITCH LENGTH (IN)	NO. OF TEETH
230H075	23	46	375H075	37.5	75	570H075	57	114	810H075	81	162
240H075	24	48	390H075	39	78	580H075	58	116	820H075	82	164
255H075	25.5	51	400H075	40	80	600H075	60	120	850H075	85	170
270H075	27	54	410H075	41	82	630H075	63	126	860H075	86	172
280H075	28	56	420H075	42	84	650H075	65	130	900H075	90	180
300H075	30	60	430H075	43	86	660H075	66	132	950H075	95	190
310H075	31	62	450H075	45	90	670H075	67	134	1000H075	100	200
315H075	31.5	63	465H075	46.5	93	680H075	68	136	1100H075	110	220
320H075	32	64	480H075	48	96	700H075	70	140	1120H075	112	224
330H075	33	66	490H075	49	98	720H075	72	144	1140H075	114	228
335H075	33.5	67	510H075	51	102	730H075	73	146	1150H075	115	230
340H075	34	68	520H075	52	104	750H075	75	150	1250H075	125	250
350H075	35	70	530H075	53	106	770H075	77	154	1400H075	140	280
360H075	36	72	540H075	54	108	800H075	80	160	1700H075	170	340
370H075	37	74	560H075	56	112						
230H100	23	46	375H100	37.5	75	570H100	57	114	810H100	81	162
240H100	24	48	390H100	39	78	580H100	58	116	820H100	82	164
255H100	25.5	51	400H100	40	80	600H100	60	120	850H100	85	170
270H100	27	54	410H100	41	82	630H100	63	126	860H100	86	172
280H100	28	56	420H100	42	84	650H100	65	130	900H100	90	180
300H100	30	60	430H100	43	86	660H100	66	132	950H100	95	190
310H100	31	62	450H100	45	90	670H100	67	134	1000H100	100	200
315H100	31.5	63	465H100	46.5	93	680H100	68	136	1100H100	110	220
320H100	32	64	480H100	48	96	700H100	70	140	1120H100	112	224
330H100	33	66	490H100	49	98	720H100	72	144	1140H100	114	228
335H100	33.5	67	510H100	51	102	730H100	73	146	1150H100	115	230
340H100	34	68	520H100	52	104	750H100	75	150	1250H100	125	250
350H100	35	70	530H100	53	106	770H100	77	154	1400H100	140	280
360H100	36	72	540H100	54	108	800H100	80	160	1700H100	170	340
370H100	37	74	560H100	56	112						
230H150	23	46	330H150	33	66	410H150	41	82	530H150	53	106
240H150	24	48	335H150	33.5	67	420H150	42	84	540H150	54	108
255H150	25.5	51	340H150	34	68	430H150	43	86	560H150	56	112
270H150	27	54	350H150	35	70	450H150	45	90	570H150	57	114
280H150	28	56	360H150	36	72	465H150	46.5	93	580H150	58	116
300H150	30	60	370H150	37	74	480H150	48	96	600H150	60	120
310H150	31	62	375H150	37.5	75	490H150	49	98	630H150	63	126
315H150	31.5	63	390H150	39	78	510H150	51	102			
320H150	32	64	400H150	40	80	520H150	52	104			

**H CONTINUED PG 80**

**EXAMPLE SIZING:**

Part Number: 600H100

600 = 60 in. Pitch Length H = Section Size 100 = 1 in. Belt Width

Part Number: 270H150

270 = 27 in. Pitch Length H = Section Size 150 = 1.5 in. Belt Width

Contact an OPTIBELT representative regarding additional sizes, stock availability and pricing.

**EXPEDITED SHIPPING:** Each OPTIBELT warehouse facility cuts timing belts to width for faster order service.



H SECTION .500 IN. PITCH

**ZR TIMING**

SAMPLE PART # : 450H200

PART NUMBER	PITCH LENGTH (IN)	NO. OF TEETH	PART NUMBER	PITCH LENGTH (IN)	NO. OF TEETH	PART NUMBER	PITCH LENGTH (IN)	NO. OF TEETH	PART NUMBER	PITCH LENGTH (IN)	NO. OF TEETH
650H150	65	130	730H150	73	146	850H150	85	170	1120H150	112	224
660H150	66	132	750H150	75	150	860H150	86	172	1140H150	114	228
670H150	67	134	770H150	77	154	900H150	90	180	1150H150	115	230
680H150	68	136	800H150	80	160	950H150	95	190	1250H150	125	250
700H150	70	140	810H150	81	162	1000H150	100	200	1400H150	140	280
720H150	72	144	820H150	82	164	1100H150	110	220	1700H150	170	340
230H200	23	46	375H200	37.5	75	570H200	57	114	810H200	81	162
240H200	24	48	390H200	39	78	580H200	58	116	820H200	82	164
255H200	25.5	51	400H200	40	80	600H200	60	120	850H200	85	170
270H200	27	54	410H200	41	82	630H200	63	126	860H200	86	172
280H200	28	56	420H200	42	84	650H200	65	130	900H200	90	180
300H200	30	60	430H200	43	86	660H200	66	132	950H200	95	190
310H200	31	62	450H200	45	90	670H200	67	134	1000H200	100	200
315H200	31.5	63	465H200	46.5	93	680H200	68	136	1100H200	110	220
320H200	32	64	480H200	48	96	700H200	70	140	1120H200	112	224
330H200	33	66	490H200	49	98	720H200	72	144	1140H200	114	228
335H200	33.5	67	510H200	51	102	730H200	73	146	1150H200	115	230
340H200	34	68	520H200	52	104	750H200	75	150	1250H200	125	250
350H200	35	70	530H200	53	106	770H200	77	154	1400H200	140	280
360H200	36	72	540H200	54	108	800H200	80	160	1700H200	170	340
370H200	37	74	560H200	56	112						
230H300	23	46	375H300	37.5	75	570H300	57	114	820H300	82	164
240H300	24	48	390H300	39	78	580H300	58	116	850H300	85	170
255H300	25.5	51	400H300	40	80	600H300	60	120	860H300	86	172
270H300	27	54	410H300	41	82	630H300	63	126	900H300	90	180
280H300	28	56	420H300	42	84	650H300	65	130	950H300	95	190
300H300	30	60	430H300	43	86	660H300	66	132	1000H300	100	200
310H300	31	62	450H300	45	90	670H300	67	134	1100H300	110	220
315H300	31.5	63	465H300	46.5	93	680H300	68	136	1120H300	112	224
320H300	32	64	480H300	48	96	700H300	70	140	1140H300	114	228
330H300	33	66	490H300	49	98	720H300	72	144	1150H300	115	230
335H300	33.5	67	510H300	51	102	730H300	73	146	1250H300	125	250
340H300	34	68	520H300	52	104	750H300	75	150	1400H300	140	280
350H300	35	70	530H300	53	106	770H300	77	154	1700H300	170	340
360H300	36	72	540H300	54	108	800H300	80	160			
370H300	37	74	560H300	56	112	810H300	81	162			

**H CONTINUED PG 81**

**ZR H**  
ZR TIMING

Contact an OPTIBELT representative regarding additional sizes, stock availability and pricing.

**EXPEDITED SHIPPING:** Each OPTIBELT warehouse facility cuts timing belts to width for faster order service.

**EXAMPLE SIZING:**

Part Number: 650H200

650 = 65 in. Pitch Length H = Section Size 200 = 2 in. Belt Width

Part Number: 300H300

300 = 30 in. Pitch Length L = Section Size 300 = 3 in. Belt Width



SAMPLE PART # : 630H100

**ZR TIMING**

H SECTION .500 IN. PITCH

PART NUMBER	PITCH LENGTH (IN)	NO. OF TEETH	PART NUMBER	PITCH LENGTH (IN)	NO. OF TEETH	PART NUMBER	PITCH LENGTH (IN)	NO. OF TEETH	PART NUMBER	PITCH LENGTH (IN)	NO. OF TEETH
230H400	23	46	375H400	37.5	75	570H400	57	114	810H400	81	162
240H400	24	48	390H400	39	78	580H400	58	116	820H400	82	164
255H400	25.5	51	400H400	40	80	600H400	60	120	850H400	85	170
270H400	27	54	410H400	41	82	630H400	63	126	860H400	86	172
280H400	28	56	420H400	42	84	650H400	65	130	900H400	90	180
300H400	30	60	430H400	43	86	660H400	66	132	950H400	95	190
310H400	31	62	450H400	45	90	670H400	67	134	1000H400	100	200
315H400	31.5	63	465H400	46.5	93	680H400	68	136	1100H400	110	220
320H400	32	64	480H400	48	96	700H400	70	140	1120H400	112	224
330H400	33	66	490H400	49	98	720H400	72	144	1140H400	114	228
335H400	33.5	67	510H400	51	102	730H400	73	146	1150H400	115	230
340H400	34	68	520H400	52	104	750H400	75	150	1250H400	125	250
350H400	35	70	530H400	53	106	770H400	77	154	1400H400	140	280
360H400	36	72	540H400	54	108	800H400	80	160	1700H400	170	340
370H400	37	74	560H400	56	112						
230H500	23	46	375H500	37.5	75	570H500	57	114	810H500	81	162
240H500	24	48	390H500	39	78	580H500	58	116	820H500	82	164
255H500	25.5	51	400H500	40	80	600H500	60	120	850H500	85	170
270H500	27	54	410H500	41	82	630H500	63	126	860H500	86	172
280H500	28	56	420H500	42	84	650H500	65	130	900H500	90	180
300H500	30	60	430H500	43	86	660H500	66	132	950H500	95	190
310H500	31	62	450H500	45	90	670H500	67	134	1000H500	100	200
315H500	31.5	63	465H500	46.5	93	680H500	68	136	1100H500	110	220
320H500	32	64	480H500	48	96	700H500	70	140	1120H500	112	224
330H500	33	66	490H500	49	98	720H500	72	144	1140H500	114	228
335H500	33.5	67	510H500	51	102	730H500	73	146	1150H500	115	230
340H500	34	68	520H500	52	104	750H500	75	150	1250H500	125	250
350H500	35	70	530H500	53	106	770H500	77	154	1400H500	140	280
360H500	36	72	540H500	54	108	800H500	80	160	1700H500	170	340
370H500	37	74	560H500	56	112						

**CUT TO SIZE WIDTHS**

If you need a custom width timing belt, OPTIBELT has you covered. Each OPTIBELT facility can cut custom widths. This means you don't have to wait for a manufactured factory order. If it is stocked it can ship!

**EXAMPLE SIZING:**

Part Number: 520H400

520 = 52 in. Pitch Length H = Section Size 400 = 4 in. Belt Width

Part Number: 1120H500

1120 = 112 in. Pitch Length H = Section Size 500 = 5 in. Belt Width

Contact an OPTIBELT representative regarding additional sizes, stock availability and pricing.

**EXPEDITED SHIPPING:** Each OPTIBELT warehouse facility cuts timing belts to width for faster order service.



**XH SECTION .875 IN. PITCH**

**ZR TIMING**

SAMPLE PART # : 980XH300

PART NUMBER	PITCH LENGTH (IN)	NO. OF TEETH	PART NUMBER	PITCH LENGTH (IN)	NO. OF TEETH	PART NUMBER	PITCH LENGTH (IN)	NO. OF TEETH	PART NUMBER	PITCH LENGTH (IN)	NO. OF TEETH
507XH200	50.75	58	700XH200	70	80	980XH200	98	112	980XH200	98	112
560XH200	56	64	770XH200	77	88	1120XH200	112	128	1120XH200	112	128
630XH200	63	72	840XH200	84	96	1260XH200	126	144	1260XH200	126	144
507XH300	50.75	58	700XH300	70	80	980XH300	98	112	1400XH300	140	160
560XH300	56	64	770XH300	77	88	1120XH300	112	128	1540XH300	154	176
630XH300	63	72	840XH300	84	96	1260XH300	126	144	1750XH300	175	200
507XH400	50.75	58	700XH400	70	80	980XH400	98	112	1400XH400	140	160
560XH400	56	64	770XH400	77	88	1120XH400	112	128	1540XH400	154	176
630XH400	63	72	840XH400	84	96	1260XH400	126	144	1750XH400	175	200
507XH500	50.75	58	700XH500	70	80	980XH500	98	112	1400XH500	140	160
560XH500	56	64	770XH500	77	88	1120XH500	112	128	1540XH500	154	176
630XH500	63	72	840XH500	84	96	1260XH500	126	144	1750XH500	175	200
507XH600	50.75	58	700XH600	70	80	980XH600	98	112	1400XH600	140	160
560XH600	56	64	770XH600	77	88	1120XH600	112	128	1540XH600	154	176
630XH600	63	72	840XH600	84	96	1260XH600	126	144	1750XH600	175	200
507XH700	50.75	58	700XH700	70	80	980XH700	98	112	1400XH700	140	160
560XH700	56	64	770XH700	77	88	1120XH700	112	128	1540XH700	154	176
630XH700	63	72	840XH700	84	96	1260XH700	126	144	1750XH700	175	200

**XXH SECTION 1.250 IN. PITCH**

**ZR TIMING**

SAMPLE PART # : 1800XXH200

PART NUMBER	PITCH LENGTH (IN)	NO. OF TEETH	PART NUMBER	PITCH LENGTH (IN)	NO. OF TEETH	PART NUMBER	PITCH LENGTH (IN)	NO. OF TEETH	PART NUMBER	PITCH LENGTH (IN)	NO. OF TEETH
700XXH200	70	56	900XXH200	90	72	1200XXH200	120	96	1600XXH200	160	128
800XXH200	80	64	1000XXH200	100	80	1400XXH200	140	112	1800XXH200	180	144
700XXH300	70	56	900XXH300	90	72	1200XXH300	120	96	1600XXH300	160	128
800XXH300	80	64	1000XXH300	100	80	1400XXH300	140	112	1800XXH300	180	144
700XXH400	70	56	900XXH400	90	72	1200XXH400	120	96	1600XXH400	160	128
800XXH400	80	64	1000XXH400	100	80	1400XXH400	140	112	1800XXH400	180	144
700XXH500	70	56	900XXH500	90	72	1200XXH500	120	96	1600XXH500	160	128
800XXH500	80	64	1000XXH500	100	80	1400XXH500	140	112	1800XXH500	180	144

**CUT TO SIZE WIDTHS**

If you need a custom width timing belt, OPTIBELT has you covered. Each OPTIBELT facility can cut custom widths. This means you don't have to wait for a manufactured factory order. If it is stocked it can ship!

Contact an OPTIBELT representative regarding additional sizes, stock availability and pricing.

**EXPEDITED SHIPPING:** Each OPTIBELT warehouse facility cuts timing belts to width for faster order service.

**EXAMPLE SIZING:**

Part Number: 700XH600

700 = 70 in. Pitch Length XH = Section Size 600 = 6 in. Belt Width

Part Number: 1400XXH400

1400 = 140 in. Pitch Length XXH = Section Size 400 = 4 in. Belt Width



SAMPLE PART # : 200DXL025

**ZR D TIMING**

D-XL SECTION .200 IN. PITCH

PART NUMBER	PITCH LENGTH (IN)	NO. OF TEETH	PART NUMBER	PITCH LENGTH (IN)	NO. OF TEETH	PART NUMBER	PITCH LENGTH (IN)	NO. OF TEETH	PART NUMBER	PITCH LENGTH (IN)	NO. OF TEETH
150DXL025	15	75	190DXL025	19	95	230DXL025	23	115	280DXL025	28	140
160DXL025	16	80	200DXL025	20	100	240DXL025	24	120	300DXL025	30	150
170DXL025	17	85	210DXL025	21	105	250DXL025	25	125	310DXL025	31	155
180DXL025	18	90	220DXL025	22	110	260DXL025	26	130			
150DXL031	15	75	190DXL031	19	95	230DXL031	23	115	280DXL031	28	140
160DXL031	16	80	200DXL031	20	100	240DXL031	24	120	300DXL031	30	150
170DXL031	17	85	210DXL031	21	105	250DXL031	25	125	310DXL031	31	155
180DXL031	18	90	220DXL031	22	110	260DXL031	26	130			
150DXL037	15	75	190DXL037	19	95	230DXL037	23	115	280DXL037	28	140
160DXL037	16	80	200DXL037	20	100	240DXL037	24	120	300DXL037	30	150
170DXL037	17	85	210DXL037	21	105	250DXL037	25	125	310DXL037	31	155
180DXL037	18	90	220DXL037	22	110	260DXL037	26	130			

SAMPLE PART # : 390DL100

**ZR D TIMING**

D-L SECTION .375 IN. PITCH

PART NUMBER	PITCH LENGTH (IN)	NO. OF TEETH	PART NUMBER	PITCH LENGTH (IN)	NO. OF TEETH	PART NUMBER	PITCH LENGTH (IN)	NO. OF TEETH	PART NUMBER	PITCH LENGTH (IN)	NO. OF TEETH
150DL050	15	40	255DL050	25.5	68	345DL050	34.5	92	480DL050	48	128
169DL050	16.9	45	270DL050	27	72	367DL050	36.7	98	510DL050	51	136
187DL050	18.7	50	285DL050	28.5	76	390DL050	39	104	540DL050	54	144
210DL050	21	56	300DL050	30	80	420DL050	42	112	600DL050	60	160
225DL050	22.5	60	322DL050	32.2	86	450DL050	45	120	660DL050	66	176
240DL050	24	64									
150DL075	15	40	255DL075	25.5	68	345DL075	34.5	92	480DL075	48	128
169DL075	16.9	45	270DL075	27	72	367DL075	36.7	98	510DL075	51	136
187DL075	18.7	50	285DL075	28.5	76	390DL075	39	104	540DL075	54	144
210DL075	21	56	300DL075	30	80	420DL075	42	112	600DL075	60	160
225DL075	22.5	60	322DL075	32.2	86	450DL075	45	120	660DL075	66	176
240DL075	24	64									
150DL100	15	40	255DL100	25.5	68	345DL100	34.5	92	480DL100	48	128
169DL100	16.9	45	270DL100	27	72	367DL100	36.7	98	510DL100	51	136
187DL100	18.7	50	285DL100	28.5	76	390DL100	39	104	540DL100	54	144
210DL100	21	56	300DL100	30	80	420DL100	42	112	600DL100	60	160
225DL100	22.5	60	322DL100	32.2	86	450DL100	45	120	660DL100	66	176
240DL100	24	64									

D-ZR SECTIONS CONTINUED PG 84

**EXAMPLE SIZING:**

Part Number: 210DXL031  
 210 = 21 in. Pitch Length DXL = Section Size Q31 = .31 in. Belt Width  
 Part Number: 540DL075  
 540 = 54 in. Pitch Length DL = Section Size Q75 = .75 in. Belt Width

Contact an OPTIBELT representative regarding additional sizes, stock availability and pricing.

**EXPEDITED SHIPPING:** Each OPTIBELT warehouse facility cuts timing belts to width for faster order service.



DH SECTION .500 IN. PITCH

**ZR D TIMING**

SAMPLE PART # : 450DH150

PART NUMBER	PITCH LENGTH (IN)	NO. OF TEETH	PART NUMBER	PITCH LENGTH (IN)	NO. OF TEETH	PART NUMBER	PITCH LENGTH (IN)	NO. OF TEETH	PART NUMBER	PITCH LENGTH (IN)	NO. OF TEETH
240DH075	24	48	450DH075	45	90	630DH075	63	126	900DH075	90	180
270DH075	27	54	480DH075	48	96	660DH075	66	132	1000DH075	100	200
300DH075	30	60	510DH075	51	102	700DH075	70	140	1100DH075	110	220
330DH075	33	66	540DH075	54	108	750DH075	75	150	1250DH075	125	250
360DH075	36	72	570DH075	57	114	800DH075	80	160	1400DH075	140	280
390DH075	39	78	600DH075	60	120	850DH075	85	170	1700DH075	170	340
420DH075	42	84									
240DH100	24	48	450DH100	45	90	630DH100	63	126	900DH100	90	180
270DH100	27	54	480DH100	48	96	660DH100	66	132	1000DH100	100	200
300DH100	30	60	510DH100	51	102	700DH100	70	140	1100DH100	110	220
330DH100	33	66	540DH100	54	108	750DH100	75	150	1250DH100	125	250
360DH100	36	72	570DH100	57	114	800DH100	80	160	1400DH100	140	280
390DH100	39	78	600DH100	60	120	850DH100	85	170	1700DH100	170	340
420DH100	42	84									
240DH150	24	48	450DH150	45	90	630DH150	63	126	900DH150	90	180
270DH150	27	54	480DH150	48	96	660DH150	66	132	1000DH150	100	200
300DH150	30	60	510DH150	51	102	700DH150	70	140	1100DH150	110	220
330DH150	33	66	540DH150	54	108	750DH150	75	150	1250DH150	125	250
360DH150	36	72	570DH150	57	114	800DH150	80	160	1400DH150	140	280
390DH150	39	78	600DH150	60	120	850DH150	85	170	1700DH150	170	340
420DH150	42	84									
240DH200	24	48	450DH200	45	90	630DH200	63	126	900DH200	90	180
270DH200	27	54	480DH200	48	96	660DH200	66	132	1000DH200	100	200
300DH200	30	60	510DH200	51	102	700DH200	70	140	1100DH200	110	220
330DH200	33	66	540DH200	54	108	750DH200	75	150	1250DH200	125	250
360DH200	36	72	570DH200	57	114	800DH200	80	160	1400DH200	140	280
390DH200	39	78	600DH200	60	120	850DH200	85	170	1700DH200	170	340
420DH200	42	84									
240DH300	24	48	450DH300	45	90	630DH300	63	126	900DH300	90	180
270DH300	27	54	480DH300	48	96	660DH300	66	132	1000DH300	100	200
300DH300	30	60	510DH300	51	102	700DH300	70	140	1100DH300	110	220
330DH300	33	66	540DH300	54	108	750DH300	75	150	1250DH300	125	250
360DH300	36	72	570DH300	57	114	800DH300	80	160	1400DH300	140	280
390DH300	39	78	600DH300	60	120	850DH300	85	170	1700DH300	170	340
420DH300	42	84									

ZR DOUBLE  
ZR TIMING

Contact an OPTIBELT representative regarding additional sizes, stock availability and pricing.

**EXPEDITED SHIPPING:** Each OPTIBELT warehouse facility cuts timing belts to width for faster order service.

**EXAMPLE SIZING:**

Part Number: 480DH150

480 = 48 in. Pitch Length DH = Section Size 150 = 1.5 in. Belt Width

Part Number: 1250DH200

1250 = 125 in. Pitch Length DH = Section Size 200 = 2 in. Belt Width



SAMPLE PART # : 6T2.5/915

**POLYURETHANE TIMING**

T2.5 SECTION 2.5 MM PITCH

PART NUMBER	PITCH LENGTH (MM)	NO. OF TEETH	PART NUMBER	PITCH LENGTH (MM)	NO. OF TEETH	PART NUMBER	PITCH LENGTH (MM)	NO. OF TEETH	PART NUMBER	PITCH LENGTH (MM)	NO. OF TEETH
4T2.5/120	120	48	4T2.5/230	230	92	4T2.5/317	317	127	4T2.5/540	540	216
4T2.5/145	145	58	4T2.5/245	245	98	4T2.5/330	330	132	4T2.5/600	600	240
4T2.5/160	160	64	4T2.5/265	265	106	4T2.5/342	342	137	4T2.5/620	620	248
4T2.5/177	177	71	4T2.5/277	277	111	4T2.5/380	380	152	4T2.5/650	650	260
4T2.5/180	180	72	4T2.5/285	285	114	4T2.5/420	420	168	4T2.5/780	780	312
4T2.5/200	200	80	4T2.5/290	290	116	4T2.5/480	480	192	4T2.5/915	915	366
4T2.5/210	210	84	4T2.5/305	305	122	4T2.5/500	500	200	4T2.5/950	950	380
6T2.5/120	120	48	6T2.5/230	230	92	6T2.5/317	317	127	6T2.5/540	540	216
6T2.5/145	145	58	6T2.5/245	245	98	6T2.5/330	330	132	6T2.5/600	600	240
6T2.5/160	160	64	6T2.5/265	265	106	6T2.5/342	342	137	6T2.5/620	620	248
6T2.5/177	177	71	6T2.5/277	277	111	6T2.5/380	380	152	6T2.5/650	650	260
6T2.5/180	180	72	6T2.5/285	285	114	6T2.5/420	420	168	6T2.5/780	780	312
6T2.5/200	200	80	6T2.5/290	290	116	6T2.5/480	480	192	6T2.5/915	915	366
6T2.5/210	210	84	6T2.5/305	305	122	6T2.5/500	500	200	6T2.5/950	950	380
8T2.5/120	120	48	8T2.5/230	230	92	8T2.5/317	317	127	8T2.5/540	540	216
8T2.5/145	145	58	8T2.5/245	245	98	8T2.5/330	330	132	8T2.5/600	600	240
8T2.5/160	160	64	8T2.5/265	265	106	8T2.5/342	342	137	8T2.5/620	620	248
8T2.5/177	177	71	8T2.5/277	277	111	8T2.5/380	380	152	8T2.5/650	650	260
8T2.5/180	180	72	8T2.5/285	285	114	8T2.5/420	420	168	8T2.5/780	780	312
8T2.5/200	200	80	8T2.5/290	290	116	8T2.5/480	480	192	8T2.5/915	915	366
8T2.5/210	210	84	8T2.5/305	305	122	8T2.5/500	500	200	8T2.5/950	950	380
10T2.5/120	120	48	10T2.5/230	230	92	10T2.5/317	317	127	10T2.5/540	540	216
10T2.5/145	145	58	10T2.5/245	245	98	10T2.5/330	330	132	10T2.5/600	600	240
10T2.5/160	160	64	10T2.5/265	265	106	10T2.5/342	342	137	10T2.5/620	620	248
10T2.5/177	177	71	10T2.5/277	277	111	10T2.5/380	380	152	10T2.5/650	650	260
10T2.5/180	180	72	10T2.5/285	285	114	10T2.5/420	420	168	10T2.5/780	780	312
10T2.5/200	200	80	10T2.5/290	290	116	10T2.5/480	480	192	10T2.5/915	915	366
10T2.5/210	210	84	10T2.5/305	305	122	10T2.5/500	500	200	10T2.5/950	950	380
12T2.5/120	120	48	12T2.5/230	230	92	12T2.5/317	317	127	12T2.5/540	540	216
12T2.5/145	145	58	12T2.5/245	245	98	12T2.5/330	330	132	12T2.5/600	600	240
12T2.5/160	160	64	12T2.5/265	265	106	12T2.5/342	342	137	12T2.5/620	620	248
12T2.5/177	177	71	12T2.5/277	277	111	12T2.5/380	380	152	12T2.5/650	650	260
12T2.5/180	180	72	12T2.5/285	285	114	12T2.5/420	420	168	12T2.5/780	780	312
12T2.5/200	200	80	12T2.5/290	290	116	12T2.5/480	480	192	12T2.5/915	915	366
12T2.5/210	210	84	12T2.5/305	305	122	12T2.5/500	500	200	12T2.5/950	950	380

**ALPHA POWER ORDERING:** When ordering ALPHA POWER construction, add "AP" to the end of the part number.  
EXAMPLE: 12T2.5/120 = ALPHA TORQUE part number, 12T2.5/120AP = ALPHA POWER part number

**ALPHA T2.5**  
POLYURETHANE

**EXAMPLE SIZING:**

Part Number: 6T2.5/177AP  
 6 = 6 mm Belt Width T2.5 = Section Size 177 = 177 mm Pitch Length AP = ALPHA POWER  
 Part Number: 10T2.5/420 (ALPHA TORQUE)  
 10 = 10 mm Belt Width T2.5 = Section Size 420 = 420 mm Pitch Length

Contact an OPTIBELT representative regarding additional sizes, stock availability and pricing.

**EXPEDITED SHIPPING:** Each OPTIBELT warehouse facility cuts timing belts to width for faster order service.



T5 SECTION 5 MM PITCH

POLYURETHANE TIMING

SAMPLE PART # : 8T5/375

PART NUMBER	PITCH LENGTH (MM)	NO. OF TEETH	PART NUMBER	PITCH LENGTH (MM)	NO. OF TEETH	PART NUMBER	PITCH LENGTH (MM)	NO. OF TEETH	PART NUMBER	PITCH LENGTH (MM)	NO. OF TEETH
6T5/165	165	33	6T5/340	340	68	6T5/510	510	102	6T5/725	725	145
6T5/185	185	37	6T5/350	350	70	6T5/525	525	105	6T5/750	750	150
6T5/200	200	40	6T5/355	355	71	6T5/545	545	109	6T5/780	780	156
6T5/215	215	43	6T5/365	365	73	6T5/550	550	110	6T5/800	800	160
6T5/220	220	44	6T5/375	375	75	6T5/560	560	112	6T5/815	815	163
6T5/225	225	45	6T5/390	390	78	6T5/575	575	115	6T5/840	840	168
6T5/245	245	49	6T5/400	400	80	6T5/590	590	118	6T5/850	850	170
6T5/250	250	50	6T5/410	410	82	6T5/600	600	120	6T5/900	900	180
6T5/255	255	51	6T5/420	420	84	6T5/610	610	122	6T5/940	940	188
6T5/260	260	52	6T5/425	425	85	6T5/620	620	124	6T5/990	990	198
6T5/270	270	54	6T5/430	430	86	6T5/625	625	125	6T5/1000	1000	200
6T5/275	275	55	6T5/440	440	88	6T5/630	630	126	6T5/1075	1075	215
6T5/280	280	56	6T5/445	445	89	6T5/640	640	128	6T5/1100	1100	220
6T5/295	295	59	6T5/450	450	90	6T5/650	650	130	6T5/1140	1140	228
6T5/300	300	60	6T5/455	455	91	6T5/660	660	132	6T5/1215	1215	243
6T5/305	305	61	6T5/460	460	92	6T5/675	675	135	6T5/1315	1315	263
6T5/320	320	64	6T5/475	475	95	6T5/690	690	138	6T5/1350	1350	270
6T5/325	325	65	6T5/480	480	96	6T5/700	700	140	6T5/1440	1440	288
6T5/330	330	66	6T5/500	500	100	6T5/720	720	144			
8T5/165	165	33	8T5/340	340	68	8T5/510	510	102	8T5/725	725	145
8T5/185	185	37	8T5/350	350	70	8T5/525	525	105	8T5/750	750	150
8T5/200	200	40	8T5/355	355	71	8T5/545	545	109	8T5/780	780	156
8T5/215	215	43	8T5/365	365	73	8T5/550	550	110	8T5/800	800	160
8T5/220	220	44	8T5/375	375	75	8T5/560	560	112	8T5/815	815	163
8T5/225	225	45	8T5/390	390	78	8T5/575	575	115	8T5/840	840	168
8T5/245	245	49	8T5/400	400	80	8T5/590	590	118	8T5/850	850	170
8T5/250	250	50	8T5/410	410	82	8T5/600	600	120	8T5/900	900	180
8T5/255	255	51	8T5/420	420	84	8T5/610	610	122	8T5/940	940	188
8T5/260	260	52	8T5/425	425	85	8T5/620	620	124	8T5/990	990	198
8T5/270	270	54	8T5/430	430	86	8T5/625	625	125	8T5/1000	1000	200
8T5/275	275	55	8T5/440	440	88	8T5/630	630	126	8T5/1075	1075	215
8T5/280	280	56	8T5/445	445	89	8T5/640	640	128	8T5/1100	1100	220
8T5/295	295	59	8T5/450	450	90	8T5/650	650	130	8T5/1140	1140	228
8T5/300	300	60	8T5/455	455	91	8T5/660	660	132	8T5/1215	1215	243
8T5/305	305	61	8T5/460	460	92	8T5/675	675	135	8T5/1315	1315	263
8T5/320	320	64	8T5/475	475	95	8T5/690	690	138	8T5/1350	1350	270
8T5/325	325	65	8T5/480	480	96	8T5/700	700	140	8T5/1440	1440	288
8T5/330	330	66	8T5/500	500	100	8T5/720	720	144			

T5 SECTIONS CONTINUED PG 87

**ALPHA POWER ORDERING:** When ordering ALPHA POWER construction, add "AP" to the end of the part number.  
EXAMPLE: 8T5/280 = ALPHA TORQUE part number, 8T5/280AP = ALPHA POWER part number

Contact an OPTIBELT representative regarding additional sizes, stock availability and pricing.

**EXPEDITED SHIPPING:** Each OPTIBELT warehouse facility cuts timing belts to width for faster order service.

**EXAMPLE SIZING:**

Part Number: 6T5/620AP

6 = 6 mm Belt Width T5 = Section Size 620 = 620 mm Pitch Length AP = ALPHA POWER

Part Number: 8T5/220 (ALPHA TORQUE)

8 = 8 mm Belt Width T5 = Section Size 220 = 220 mm Pitch Length





10T5/450

**POLYURETHANE TIMING**

T5 SECTION 5 MM PITCH

PART NUMBER	PITCH LENGTH (MM)	NO. OF TEETH	PART NUMBER	PITCH LENGTH (MM)	NO. OF TEETH	PART NUMBER	PITCH LENGTH (MM)	NO. OF TEETH	PART NUMBER	PITCH LENGTH (MM)	NO. OF TEETH
10T5/165	165	33	10T5/340	340	68	10T5/510	510	102	10T5/725	725	145
10T5/185	185	37	10T5/350	350	70	10T5/525	525	105	10T5/750	750	150
10T5/200	200	40	10T5/355	355	71	10T5/545	545	109	10T5/780	780	156
10T5/215	215	43	10T5/365	365	73	10T5/550	550	110	10T5/800	800	160
10T5/220	220	44	10T5/375	375	75	10T5/560	560	112	10T5/815	815	163
10T5/225	225	45	10T5/390	390	78	10T5/575	575	115	10T5/840	840	168
10T5/245	245	49	10T5/400	400	80	10T5/590	590	118	10T5/850	850	170
10T5/250	250	50	10T5/410	410	82	10T5/600	600	120	10T5/900	900	180
10T5/255	255	51	10T5/420	420	84	10T5/610	610	122	10T5/940	940	188
10T5/260	260	52	10T5/425	425	85	10T5/620	620	124	10T5/990	990	198
10T5/270	270	54	10T5/430	430	86	10T5/625	625	125	10T5/1000	1000	200
10T5/275	275	55	10T5/440	440	88	10T5/630	630	126	10T5/1075	1075	215
10T5/280	280	56	10T5/445	445	89	10T5/640	640	128	10T5/1100	1100	220
10T5/295	295	59	10T5/450	450	90	10T5/650	650	130	10T5/1140	1140	228
10T5/300	300	60	10T5/455	455	91	10T5/660	660	132	10T5/1215	1215	243
10T5/305	305	61	10T5/460	460	92	10T5/675	675	135	10T5/1315	1315	263
10T5/320	320	64	10T5/475	475	95	10T5/690	690	138	10T5/1350	1350	270
10T5/325	325	65	10T5/480	480	96	10T5/700	700	140	10T5/1440	1440	288
10T5/330	330	66	10T5/500	500	100	10T5/720	720	144			
12T5/165	165	33	12T5/340	340	68	12T5/510	510	102	12T5/725	725	145
12T5/185	185	37	12T5/350	350	70	12T5/525	525	105	12T5/750	750	150
12T5/200	200	40	12T5/355	355	71	12T5/545	545	109	12T5/780	780	156
12T5/215	215	43	12T5/365	365	73	12T5/550	550	110	12T5/800	800	160
12T5/220	220	44	12T5/375	375	75	12T5/560	560	112	12T5/815	815	163
12T5/225	225	45	12T5/390	390	78	12T5/575	575	115	12T5/840	840	168
12T5/245	245	49	12T5/400	400	80	12T5/590	590	118	12T5/850	850	170
12T5/250	250	50	12T5/410	410	82	12T5/600	600	120	12T5/900	900	180
12T5/255	255	51	12T5/420	420	84	12T5/610	610	122	12T5/940	940	188
12T5/260	260	52	12T5/425	425	85	12T5/620	620	124	12T5/990	990	198
12T5/270	270	54	12T5/430	430	86	12T5/625	625	125	12T5/1000	1000	200
12T5/275	275	55	12T5/440	440	88	12T5/630	630	126	12T5/1075	1075	215
12T5/280	280	56	12T5/445	445	89	12T5/640	640	128	12T5/1100	1100	220
12T5/295	295	59	12T5/450	450	90	12T5/650	650	130	12T5/1140	1140	228
12T5/300	300	60	12T5/455	455	91	12T5/660	660	132	12T5/1215	1215	243
12T5/305	305	61	12T5/460	460	92	12T5/675	675	135	12T5/1315	1315	263
12T5/320	320	64	12T5/475	475	95	12T5/690	690	138	12T5/1350	1350	270
12T5/325	325	65	12T5/480	480	96	12T5/700	700	140	12T5/1440	1440	288
12T5/330	330	66	12T5/500	500	100	12T5/720	720	144			

**T5 SECTIONS CONTINUED PG 88**

**ALPHA POWER ORDERING:** When ordering ALPHA POWER construction, add "AP" to the end of the part number.  
EXAMPLE: 12T5/280 = ALPHA TORQUE part number, 12T5/280AP = ALPHA POWER part number

**EXAMPLE SIZING:**

Part Number: 10T5/1100 (ALPHA TORQUE)

10 = 10 mm Belt Width T5 = Section Size 1100 = 1100 mm Pitch Length

Part Number: 12T5/430AP

12 = 12 mm Belt Width T5 = Section Size 430 = 430 mm Pitch Length AP = ALPHA POWER

Contact an OPTIBELT representative regarding additional sizes, stock availability and pricing.

**EXPEDITED SHIPPING:** Each OPTIBELT warehouse facility cuts timing belts to width for faster order service.



T5 SECTION 5 MM PITCH

**POLYURETHANE TIMING**

SAMPLE PART #: 20T5/510

PART NUMBER	PITCH LENGTH (MM)	NO. OF TEETH	PART NUMBER	PITCH LENGTH (MM)	NO. OF TEETH	PART NUMBER	PITCH LENGTH (MM)	NO. OF TEETH	PART NUMBER	PITCH LENGTH (MM)	NO. OF TEETH
16T5/165	165	33	16T5/340	340	68	16T5/510	510	102	16T5/725	725	145
16T5/185	185	37	16T5/350	350	70	16T5/525	525	105	16T5/750	750	150
16T5/200	200	40	16T5/355	355	71	16T5/545	545	109	16T5/780	780	156
16T5/215	215	43	16T5/365	365	73	16T5/550	550	110	16T5/800	800	160
16T5/220	220	44	16T5/375	375	75	16T5/560	560	112	16T5/815	815	163
16T5/225	225	45	16T5/390	390	78	16T5/575	575	115	16T5/840	840	168
16T5/245	245	49	16T5/400	400	80	16T5/590	590	118	16T5/850	850	170
16T5/250	250	50	16T5/410	410	82	16T5/600	600	120	16T5/900	900	180
16T5/255	255	51	16T5/420	420	84	16T5/610	610	122	16T5/940	940	188
16T5/260	260	52	16T5/425	425	85	16T5/620	620	124	16T5/990	990	198
16T5/270	270	54	16T5/430	430	86	16T5/625	625	125	16T5/1000	1000	200
16T5/275	275	55	16T5/440	440	88	16T5/630	630	126	16T5/1075	1075	215
16T5/280	280	56	16T5/445	445	89	16T5/640	640	128	16T5/1100	1100	220
16T5/295	295	59	16T5/450	450	90	16T5/650	650	130	16T5/1140	1140	228
16T5/300	300	60	16T5/455	455	91	16T5/660	660	132	16T5/1215	1215	243
16T5/305	305	61	16T5/460	460	92	16T5/675	675	135	16T5/1315	1315	263
16T5/320	320	64	16T5/475	475	95	16T5/690	690	138	16T5/1350	1350	270
16T5/325	325	65	16T5/480	480	96	16T5/700	700	140	16T5/1440	1440	288
16T5/330	330	66	16T5/500	500	100	16T5/720	720	144			
20T5/165	165	33	20T5/340	340	68	20T5/510	510	102	20T5/725	725	145
20T5/185	185	37	20T5/350	350	70	20T5/525	525	105	20T5/750	750	150
20T5/200	200	40	20T5/355	355	71	20T5/545	545	109	20T5/780	780	156
20T5/215	215	43	20T5/365	365	73	20T5/550	550	110	20T5/800	800	160
20T5/220	220	44	20T5/375	375	75	20T5/560	560	112	20T5/815	815	163
20T5/225	225	45	20T5/390	390	78	20T5/575	575	115	20T5/840	840	168
20T5/245	245	49	20T5/400	400	80	20T5/590	590	118	20T5/850	850	170
20T5/250	250	50	20T5/410	410	82	20T5/600	600	120	20T5/900	900	180
20T5/255	255	51	20T5/420	420	84	20T5/610	610	122	20T5/940	940	188
20T5/260	260	52	20T5/425	425	85	20T5/620	620	124	20T5/990	990	198
20T5/270	270	54	20T5/430	430	86	20T5/625	625	125	20T5/1000	1000	200
20T5/275	275	55	20T5/440	440	88	20T5/630	630	126	20T5/1075	1075	215
20T5/280	280	56	20T5/445	445	89	20T5/640	640	128	20T5/1100	1100	220
20T5/295	295	59	20T5/450	450	90	20T5/650	650	130	20T5/1140	1140	228
20T5/300	300	60	20T5/455	455	91	20T5/660	660	132	20T5/1215	1215	243
20T5/305	305	61	20T5/460	460	92	20T5/675	675	135	20T5/1315	1315	263
20T5/320	320	64	20T5/475	475	95	20T5/690	690	138	20T5/1350	1350	270
20T5/325	325	65	20T5/480	480	96	20T5/700	700	140	20T5/1440	1440	288
20T5/330	330	66	20T5/500	500	100	20T5/720	720	144			

**T5 SECTIONS CONTINUED PG 89**

**ALPHA POWER ORDERING:** When ordering ALPHA POWER construction, add "AP" to the end of the part number.  
EXAMPLE: 20T5/720 = ALPHA TORQUE part number, 20T5/720AP = ALPHA POWER part number

Contact an OPTIBELT representative regarding additional sizes, stock availability and pricing.

**EXPEDITED SHIPPING:** Each OPTIBELT warehouse facility cuts timing belts to width for faster order service.

**EXAMPLE SIZING:**

Part Number: 16T5/620AP

16 = 16 mm Belt Width T5 = Section Size 620 = 620 mm Pitch Length AP = ALPHA POWER

Part Number: 20T5/610 (ALPHA TORQUE)

20 = 20 mm Belt Width T5 = Section Size 610 = 610 mm Pitch Length



SAMPLE PART # : 25T5/600

**POLYURETHANE TIMING**

T5 SECTION 5 MM PITCH

PART NUMBER	PITCH LENGTH (MM)	NO. OF TEETH	PART NUMBER	PITCH LENGTH (MM)	NO. OF TEETH	PART NUMBER	PITCH LENGTH (MM)	NO. OF TEETH	PART NUMBER	PITCH LENGTH (MM)	NO. OF TEETH
25T5/165	165	33	25T5/340	340	68	25T5/510	510	102	25T5/725	725	145
25T5/185	185	37	25T5/350	350	70	25T5/525	525	105	25T5/750	750	150
25T5/200	200	40	25T5/355	355	71	25T5/545	545	109	25T5/780	780	156
25T5/215	215	43	25T5/365	365	73	25T5/550	550	110	25T5/800	800	160
25T5/220	220	44	25T5/375	375	75	25T5/560	560	112	25T5/815	815	163
25T5/225	225	45	25T5/390	390	78	25T5/575	575	115	25T5/840	840	168
25T5/245	245	49	25T5/400	400	80	25T5/590	590	118	25T5/850	850	170
25T5/250	250	50	25T5/410	410	82	25T5/600	600	120	25T5/900	900	180
25T5/255	255	51	25T5/420	420	84	25T5/610	610	122	25T5/940	940	188
25T5/260	260	52	25T5/425	425	85	25T5/620	620	124	25T5/990	990	198
25T5/270	270	54	25T5/430	430	86	25T5/625	625	125	25T5/1000	1000	200
25T5/275	275	55	25T5/440	440	88	25T5/630	630	126	25T5/1075	1075	215
25T5/280	280	56	25T5/445	445	89	25T5/640	640	128	25T5/1100	1100	220
25T5/295	295	59	25T5/450	450	90	25T5/650	650	130	25T5/1140	1140	228
25T5/300	300	60	25T5/455	455	91	25T5/660	660	132	25T5/1215	1215	243
25T5/305	305	61	25T5/460	460	92	25T5/675	675	135	25T5/1315	1315	263
25T5/320	320	64	25T5/475	475	95	25T5/690	690	138	25T5/1350	1350	270
25T5/325	325	65	25T5/480	480	96	25T5/700	700	140	25T5/1440	1440	288
25T5/330	330	66	25T5/500	500	100	25T5/720	720	144			

**ALPHA POWER ORDERING:** When ordering ALPHA POWER construction, add "AP" to the end of the part number.  
EXAMPLE: 25T5/410 = ALPHA TORQUE part number, 25T5/410AP = ALPHA POWER part number

**CUT TO SIZE WIDTHS**

If you need a custom width timing belt, OPTIBELT has you covered. Each OPTIBELT facility can cut custom widths. This means you don't have to wait for a manufactured factory order. If it is stocked it can ship!

**EXAMPLE SIZING:**

Part Number: 25T5/250AP

25 = 25 mm Belt Width T5 = Section Size 250 = 250 mm Pitch Length AP = ALPHA POWER

Part Number: 25T5/675 (ALPHA TORQUE)

25 = 25 mm Belt Width T5 = Section Size 675 = 675 mm Pitch Length

Contact an OPTIBELT representative regarding additional sizes, stock availability and pricing.

**EXPEDITED SHIPPING:** Each OPTIBELT warehouse facility cuts timing belts to width for faster order service.



T10 SECTION 10 MM PITCH

POLYURETHANE TIMING

SAMPLE PART # : 10T10/1350

PART NUMBER	PITCH LENGTH (MM)	NO. OF TEETH	PART NUMBER	PITCH LENGTH (MM)	NO. OF TEETH	PART NUMBER	PITCH LENGTH (MM)	NO. OF TEETH	PART NUMBER	PITCH LENGTH (MM)	NO. OF TEETH
10T10/260	260	26	10T10/690	690	69	10T10/980	980	98	10T10/1400	1400	140
10T10/320	320	32	10T10/700	700	70	10T10/1000	1000	100	10T10/1420	1420	142
10T10/350	350	35	10T10/720	720	72	10T10/1010	1010	101	10T10/1440	1440	144
10T10/370	370	37	10T10/750	750	75	10T10/1050	1050	105	10T10/1450	1450	145
10T10/400	400	40	10T10/780	780	78	10T10/1080	1080	108	10T10/1460	1460	146
10T10/410	410	41	10T10/800	800	80	10T10/1100	1100	110	10T10/1500	1500	150
10T10/440	440	44	10T10/810	810	81	10T10/1140	1140	114	10T10/1560	1560	156
10T10/450	450	45	10T10/840	840	84	10T10/1150	1150	115	10T10/1600	1600	160
10T10/500	500	50	10T10/850	850	85	10T10/1200	1200	120	10T10/1610	1610	161
10T10/530	530	53	10T10/880	880	88	10T10/1210	1210	121	10T10/1700	1700	170
10T10/550	550	55	10T10/890	890	89	10T10/1240	1240	124	10T10/1750	1750	175
10T10/560	560	56	10T10/900	900	90	10T10/1250	1250	125	10T10/1780	1780	178
10T10/600	600	60	10T10/910	910	91	10T10/1300	1300	130	10T10/1800	1800	180
10T10/610	610	61	10T10/920	920	92	10T10/1320	1320	132	10T10/1880	1880	188
10T10/630	630	63	10T10/950	950	95	10T10/1350	1350	135	10T10/1960	1960	196
10T10/650	650	65	10T10/960	960	96	10T10/1390	1390	139	10T10/2250	2250	225
10T10/660	660	66	10T10/970	970	97						

12T10/260	260	26	12T10/690	690	69	12T10/980	980	98	12T10/1400	1400	140
12T10/320	320	32	12T10/700	700	70	12T10/1000	1000	100	12T10/1420	1420	142
12T10/350	350	35	12T10/720	720	72	12T10/1010	1010	101	12T10/1440	1440	144
12T10/370	370	37	12T10/750	750	75	12T10/1050	1050	105	12T10/1450	1450	145
12T10/400	400	40	12T10/780	780	78	12T10/1080	1080	108	12T10/1460	1460	146
12T10/410	410	41	12T10/800	800	80	12T10/1100	1100	110	12T10/1500	1500	150
12T10/440	440	44	12T10/810	810	81	12T10/1140	1140	114	12T10/1560	1560	156
12T10/450	450	45	12T10/840	840	84	12T10/1150	1150	115	12T10/1600	1600	160
12T10/500	500	50	12T10/850	850	85	12T10/1200	1200	120	12T10/1610	1610	161
12T10/530	530	53	12T10/880	880	88	12T10/1210	1210	121	12T10/1700	1700	170
12T10/550	550	55	12T10/890	890	89	12T10/1240	1240	124	12T10/1750	1750	175
12T10/560	560	56	12T10/900	900	90	12T10/1250	1250	125	12T10/1780	1780	178
12T10/600	600	60	12T10/910	910	91	12T10/1300	1300	130	12T10/1800	1800	180
12T10/610	610	61	12T10/920	920	92	12T10/1320	1320	132	12T10/1880	1880	188
12T10/630	630	63	12T10/950	950	95	12T10/1350	1350	135	12T10/1960	1960	196
12T10/650	650	65	12T10/960	960	96	12T10/1390	1390	139	12T10/2250	2250	225
12T10/660	660	66	12T10/970	970	97						

T10 SECTIONS CONTINUED PG 91

CUT TO SIZE WIDTHS

If you need a custom width timing belt, OPTIBELT has you covered. Each OPTIBELT facility can cut custom widths. This means you don't have to wait for a manufactured factory order. If it is stocked it can ship!

Contact an OPTIBELT representative regarding additional sizes, stock availability and pricing.

**EXPEDITED SHIPPING:** Each OPTIBELT warehouse facility cuts timing belts to width for faster order service.

EXAMPLE SIZING:

Part Number: 10T10/1150AP

10 = 10 mm Belt Width T10 = Section Size 1150 = 1150 mm Pitch Length AP = ALPHA POWER

Part Number: 12T10/500 (ALPHA TORQUE)

12 = 12 mm Belt Width T10 = Section Size 500 = 500 mm Pitch Length



SAMPLE PART # : 16T10/1080

**POLYURETHANE TIMING**

**T10 SECTION 10 MM PITCH**

PART NUMBER	PITCH LENGTH (MM)	NO. OF TEETH	PART NUMBER	PITCH LENGTH (MM)	NO. OF TEETH	PART NUMBER	PITCH LENGTH (MM)	NO. OF TEETH	PART NUMBER	PITCH LENGTH (MM)	NO. OF TEETH
16T10/260	260	26	16T10/690	690	69	16T10/980	980	98	16T10/1400	1400	140
16T10/320	320	32	16T10/700	700	70	16T10/1000	1000	100	16T10/1420	1420	142
16T10/350	350	35	16T10/720	720	72	16T10/1010	1010	101	16T10/1440	1440	144
16T10/370	370	37	16T10/750	750	75	16T10/1050	1050	105	16T10/1450	1450	145
16T10/400	400	40	16T10/780	780	78	16T10/1080	1080	108	16T10/1460	1460	146
16T10/410	410	41	16T10/800	800	80	16T10/1100	1100	110	16T10/1500	1500	150
16T10/440	440	44	16T10/810	810	81	16T10/1140	1140	114	16T10/1560	1560	156
16T10/450	450	45	16T10/840	840	84	16T10/1150	1150	115	16T10/1600	1600	160
16T10/500	500	50	16T10/850	850	85	16T10/1200	1200	120	16T10/1610	1610	161
16T10/530	530	53	16T10/880	880	88	16T10/1210	1210	121	16T10/1700	1700	170
16T10/550	550	55	16T10/890	890	89	16T10/1240	1240	124	16T10/1750	1750	175
16T10/560	560	56	16T10/900	900	90	16T10/1250	1250	125	16T10/1780	1780	178
16T10/600	600	60	16T10/910	910	91	16T10/1300	1300	130	16T10/1800	1800	180
16T10/610	610	61	16T10/920	920	92	16T10/1320	1320	132	16T10/1880	1880	188
16T10/630	630	63	16T10/950	950	95	16T10/1350	1350	135	16T10/1960	1960	196
16T10/650	650	65	16T10/960	960	96	16T10/1390	1390	139	16T10/2250	2250	225
16T10/660	660	66	16T10/970	970	97						

20T10/260	260	26	20T10/690	690	69	20T10/980	980	98	20T10/1400	1400	140
20T10/320	320	32	20T10/700	700	70	20T10/1000	1000	100	20T10/1420	1420	142
20T10/350	350	35	20T10/720	720	72	20T10/1010	1010	101	20T10/1440	1440	144
20T10/370	370	37	20T10/750	750	75	20T10/1050	1050	105	20T10/1450	1450	145
20T10/400	400	40	20T10/780	780	78	20T10/1080	1080	108	20T10/1460	1460	146
20T10/410	410	41	20T10/800	800	80	20T10/1100	1100	110	20T10/1500	1500	150
20T10/440	440	44	20T10/810	810	81	20T10/1140	1140	114	20T10/1560	1560	156
20T10/450	450	45	20T10/840	840	84	20T10/1150	1150	115	20T10/1600	1600	160
20T10/500	500	50	20T10/850	850	85	20T10/1200	1200	120	20T10/1610	1610	161
20T10/530	530	53	20T10/880	880	88	20T10/1210	1210	121	20T10/1700	1700	170
20T10/550	550	55	20T10/890	890	89	20T10/1240	1240	124	20T10/1750	1750	175
20T10/560	560	56	20T10/900	900	90	20T10/1250	1250	125	20T10/1780	1780	178
20T10/600	600	60	20T10/910	910	91	20T10/1300	1300	130	20T10/1800	1800	180
20T10/610	610	61	20T10/920	920	92	20T10/1320	1320	132	20T10/1880	1880	188
20T10/630	630	63	20T10/950	950	95	20T10/1350	1350	135	20T10/1960	1960	196
20T10/650	650	65	20T10/960	960	96	20T10/1390	1390	139	20T10/2250	2250	225
20T10/660	660	66	20T10/970	970	97						

**T10 SECTIONS CONTINUED PG 92**

**ALPHA T10**  
POLYURETHANE

**CUT TO SIZE WIDTHS**

If you need a custom width timing belt, OPTIBELT has you covered. Each OPTIBELT facility can cut custom widths. This means you don't have to wait for a manufactured factory order. If it is stocked it can ship!

**EXAMPLE SIZING:**

Part Number: 16T10/1150 (ALPHA TORQUE)

16 = 16 mm Belt Width T10 = Section Size 1150 = 1150 mm Pitch Length

Part Number: 20T10/350AP

20 = 20 mm Belt Width T10 = Section Size 350 = 350 mm Pitch Length AP = ALPHA POWER

Contact an OPTIBELT representative regarding additional sizes, stock availability and pricing.

**EXPEDITED SHIPPING:** Each OPTIBELT warehouse facility cuts timing belts to width for faster order service.



T10 SECTION 10 MM PITCH

**POLYURETHANE TIMING**

SAMPLE PART # : 32T10/1440

PART NUMBER	PITCH LENGTH (MM)	NO. OF TEETH	PART NUMBER	PITCH LENGTH (MM)	NO. OF TEETH	PART NUMBER	PITCH LENGTH (MM)	NO. OF TEETH	PART NUMBER	PITCH LENGTH (MM)	NO. OF TEETH
25T10/260	260	26	25T10/690	690	69	25T10/980	980	98	25T10/1400	1400	140
25T10/320	320	32	25T10/700	700	70	25T10/1000	1000	100	25T10/1420	1420	142
25T10/350	350	35	25T10/720	720	72	25T10/1010	1010	101	25T10/1440	1440	144
25T10/370	370	37	25T10/750	750	75	25T10/1050	1050	105	25T10/1450	1450	145
25T10/400	400	40	25T10/780	780	78	25T10/1080	1080	108	25T10/1460	1460	146
25T10/410	410	41	25T10/800	800	80	25T10/1100	1100	110	25T10/1500	1500	150
25T10/440	440	44	25T10/810	810	81	25T10/1140	1140	114	25T10/1560	1560	156
25T10/450	450	45	25T10/840	840	84	25T10/1150	1150	115	25T10/1600	1600	160
25T10/500	500	50	25T10/850	850	85	25T10/1200	1200	120	25T10/1610	1610	161
25T10/530	530	53	25T10/880	880	88	25T10/1210	1210	121	25T10/1700	1700	170
25T10/550	550	55	25T10/890	890	89	25T10/1240	1240	124	25T10/1750	1750	175
25T10/560	560	56	25T10/900	900	90	25T10/1250	1250	125	25T10/1780	1780	178
25T10/600	600	60	25T10/910	910	91	25T10/1300	1300	130	25T10/1800	1800	180
25T10/610	610	61	25T10/920	920	92	25T10/1320	1320	132	25T10/1880	1880	188
25T10/630	630	63	25T10/950	950	95	25T10/1350	1350	135	25T10/1960	1960	196
25T10/650	650	65	25T10/960	960	96	25T10/1390	1390	139	25T10/2250	2250	225
25T10/660	660	66	25T10/970	970	97						

32T10/260	260	26	32T10/690	690	69	32T10/980	980	98	32T10/1400	1400	140
32T10/320	320	32	32T10/700	700	70	32T10/1000	1000	100	32T10/1420	1420	142
32T10/350	350	35	32T10/720	720	72	32T10/1010	1010	101	32T10/1440	1440	144
32T10/370	370	37	32T10/750	750	75	32T10/1050	1050	105	32T10/1450	1450	145
32T10/400	400	40	32T10/780	780	78	32T10/1080	1080	108	32T10/1460	1460	146
32T10/410	410	41	32T10/800	800	80	32T10/1100	1100	110	32T10/1500	1500	150
32T10/440	440	44	32T10/810	810	81	32T10/1140	1140	114	32T10/1560	1560	156
32T10/450	450	45	32T10/840	840	84	32T10/1150	1150	115	32T10/1600	1600	160
32T10/500	500	50	32T10/850	850	85	32T10/1200	1200	120	32T10/1610	1610	161
32T10/530	530	53	32T10/880	880	88	32T10/1210	1210	121	32T10/1700	1700	170
32T10/550	550	55	32T10/890	890	89	32T10/1240	1240	124	32T10/1750	1750	175
32T10/560	560	56	32T10/900	900	90	32T10/1250	1250	125	32T10/1780	1780	178
32T10/600	600	60	32T10/910	910	91	32T10/1300	1300	130	32T10/1800	1800	180
32T10/610	610	61	32T10/920	920	92	32T10/1320	1320	132	32T10/1880	1880	188
32T10/630	630	63	32T10/950	950	95	32T10/1350	1350	135	32T10/1960	1960	196
32T10/650	650	65	32T10/960	960	96	32T10/1390	1390	139	32T10/2250	2250	225
32T10/660	660	66	32T10/970	970	97						

T10 SECTIONS CONTINUED PG 93

**CUT TO SIZE WIDTHS**

If you need a custom width timing belt, OPTIBELT has you covered. Each OPTIBELT facility can cut custom widths. This means you don't have to wait for a manufactured factory order. If it is stocked it can ship!

Contact an OPTIBELT representative regarding additional sizes, stock availability and pricing.

**EXPEDITED SHIPPING:** Each OPTIBELT warehouse facility cuts timing belts to width for faster order service.

**EXAMPLE SIZING:**  
 Part Number: 25T10/1610AP  
 25 = 25 mm Belt Width T10 = Section Size 1610 = 1610 mm Pitch Length AP = ALPHA POWER  
 Part Number: 32T10/840 (ALPHA TORQUE)  
 32 = 32 mm Belt Width T10 = Section Size 840 = 840 mm Pitch Length



SAMPLE PART # : 50T10/1500

**POLYURETHANE TIMING**

T10 SECTION 10 MM PITCH

PART NUMBER	PITCH LENGTH (MM)	NO. OF TEETH	PART NUMBER	PITCH LENGTH (MM)	NO. OF TEETH	PART NUMBER	PITCH LENGTH (MM)	NO. OF TEETH	PART NUMBER	PITCH LENGTH (MM)	NO. OF TEETH
50T10/260	260	26	50T10/690	690	69	50T10/980	980	98	50T10/1400	1400	140
50T10/320	320	32	50T10/700	700	70	50T10/1000	1000	100	50T10/1420	1420	142
50T10/350	350	35	50T10/720	720	72	50T10/1010	1010	101	50T10/1440	1440	144
50T10/370	370	37	50T10/750	750	75	50T10/1050	1050	105	50T10/1450	1450	145
50T10/400	400	40	50T10/780	780	78	50T10/1080	1080	108	50T10/1460	1460	146
50T10/410	410	41	50T10/800	800	80	50T10/1100	1100	110	50T10/1500	1500	150
50T10/440	440	44	50T10/810	810	81	50T10/1140	1140	114	50T10/1560	1560	156
50T10/450	450	45	50T10/840	840	84	50T10/1150	1150	115	50T10/1600	1600	160
50T10/500	500	50	50T10/850	850	85	50T10/1200	1200	120	50T10/1610	1610	161
50T10/530	530	53	50T10/880	880	88	50T10/1210	1210	121	50T10/1700	1700	170
50T10/550	550	55	50T10/890	890	89	50T10/1240	1240	124	50T10/1750	1750	175
50T10/560	560	56	50T10/900	900	90	50T10/1250	1250	125	50T10/1780	1780	178
50T10/600	600	60	50T10/910	910	91	50T10/1300	1300	130	50T10/1800	1800	180
50T10/610	610	61	50T10/920	920	92	50T10/1320	1320	132	50T10/1880	1880	188
50T10/630	630	63	50T10/950	950	95	50T10/1350	1350	135	50T10/1960	1960	196
50T10/650	650	65	50T10/960	960	96	50T10/1390	1390	139	50T10/2250	2250	225
50T10/660	660	66	50T10/970	970	97						

**ALPHA POWER ORDERING:** When ordering ALPHA POWER construction, add "AP" to the end of the part number.  
EXAMPLE: 50T10/1000 = ALPHA TORQUE part number, 50T10/1000AP = ALPHA POWER part number

**CUT TO SIZE WIDTHS**

If you need a custom width timing belt, OPTIBELT has you covered. Each OPTIBELT facility can cut custom widths. This means you don't have to wait for a manufactured factory order. If it is stocked it can ship!

**EXAMPLE SIZING:**

Part Number: 50T10/560AP

50 = 50 mm Belt Width T10 = Section Size 560 = 560 mm Pitch Length AP = ALPHA POWER

Part Number: 50T10/1210 (ALPHA TORQUE)

50 = 50 mm Belt Width T10 = Section Size 1210 = 1210 mm Pitch Length

Contact an OPTIBELT representative regarding additional sizes, stock availability and pricing.

**EXPEDITED SHIPPING:** Each OPTIBELT warehouse facility cuts timing belts to width for faster order service.



AT5 SECTION 5 MM PITCH

POLYURETHANE TIMING

SAMPLE PART # : 10AT5/390

PART NUMBER	PITCH LENGTH (MM)	NO. OF TEETH	PART NUMBER	PITCH LENGTH (MM)	NO. OF TEETH	PART NUMBER	PITCH LENGTH (MM)	NO. OF TEETH	PART NUMBER	PITCH LENGTH (MM)	NO. OF TEETH
6AT5/225	225	45	6AT5/390	390	78	6AT5/600	600	120	6AT5/780	780	156
6AT5/255	255	51	6AT5/420	420	84	6AT5/610	610	122	6AT5/825	825	165
6AT5/280	280	56	6AT5/450	450	90	6AT5/660	660	132	6AT5/860	860	172
6AT5/300	300	60	6AT5/455	455	91	6AT5/710	710	142	6AT5/975	975	195
6AT5/340	340	68	6AT5/500	500	100	6AT5/720	720	144	6AT5/1050	1050	210
6AT5/375	375	75	6AT5/545	545	109	6AT5/750	750	150	6AT5/1500	1500	300
8AT5/225	225	45	8AT5/390	390	78	8AT5/600	600	120	8AT5/780	780	156
8AT5/255	255	51	8AT5/420	420	84	8AT5/610	610	122	8AT5/825	825	165
8AT5/280	280	56	8AT5/450	450	90	8AT5/660	660	132	8AT5/860	860	172
8AT5/300	300	60	8AT5/455	455	91	8AT5/710	710	142	8AT5/975	975	195
8AT5/340	340	68	8AT5/500	500	100	8AT5/720	720	144	8AT5/1050	1050	210
8AT5/375	375	75	8AT5/545	545	109	8AT5/750	750	150	8AT5/1500	1500	300
10AT5/225	225	45	10AT5/390	390	78	10AT5/600	600	120	10AT5/780	780	156
10AT5/255	255	51	10AT5/420	420	84	10AT5/610	610	122	10AT5/825	825	165
10AT5/280	280	56	10AT5/450	450	90	10AT5/660	660	132	10AT5/860	860	172
10AT5/300	300	60	10AT5/455	455	91	10AT5/710	710	142	10AT5/975	975	195
10AT5/340	340	68	10AT5/500	500	100	10AT5/720	720	144	10AT5/1050	1050	210
10AT5/375	375	75	10AT5/545	545	109	10AT5/750	750	150	10AT5/1500	1500	300
12AT5/225	225	45	12AT5/390	390	78	12AT5/600	600	120	12AT5/780	780	156
12AT5/255	255	51	12AT5/420	420	84	12AT5/610	610	122	12AT5/825	825	165
12AT5/280	280	56	12AT5/450	450	90	12AT5/660	660	132	12AT5/860	860	172
12AT5/300	300	60	12AT5/455	455	91	12AT5/710	710	142	12AT5/975	975	195
12AT5/340	340	68	12AT5/500	500	100	12AT5/720	720	144	12AT5/1050	1050	210
12AT5/375	375	75	12AT5/545	545	109	12AT5/750	750	150	12AT5/1500	1500	300
16AT5/225	225	45	16AT5/390	390	78	16AT5/600	600	120	16AT5/780	780	156
16AT5/255	255	51	16AT5/420	420	84	16AT5/610	610	122	16AT5/825	825	165
16AT5/280	280	56	16AT5/450	450	90	16AT5/660	660	132	16AT5/860	860	172
16AT5/300	300	60	16AT5/455	455	91	16AT5/710	710	142	16AT5/975	975	195
16AT5/340	340	68	16AT5/500	500	100	16AT5/720	720	144	16AT5/1050	1050	210
16AT5/375	375	75	16AT5/545	545	109	16AT5/750	750	150	16AT5/1500	1500	300
20AT5/225	225	45	20AT5/390	390	78	20AT5/600	600	120	20AT5/780	780	156
20AT5/255	255	51	20AT5/420	420	84	20AT5/610	610	122	20AT5/825	825	165
20AT5/280	280	56	20AT5/450	450	90	20AT5/660	660	132	20AT5/860	860	172
20AT5/300	300	60	20AT5/455	455	91	20AT5/710	710	142	20AT5/975	975	195
20AT5/340	340	68	20AT5/500	500	100	20AT5/720	720	144	20AT5/1050	1050	210
20AT5/375	375	75	20AT5/545	545	109	20AT5/750	750	150	20AT5/1500	1500	300

AT5 SECTIONS CONTINUED PG 95

Contact an OPTIBELT representative regarding additional sizes, stock availability and pricing.

**EXPEDITED SHIPPING:** Each OPTIBELT warehouse facility cuts timing belts to width for faster order service.

**EXAMPLE SIZING:**

Part Number: 6AT5/450 (ALPHA TORQUE)

6 = 6 mm Belt Width AT5 = Section Size 450 = 450 mm Pitch Length

Part Number: 12AT5/720AP

12 = 12 mm Belt Width AT5 = Section Size 720 = 720 mm Pitch Length AP = ALPHA POWER





SAMPLE PART # : 25AT5/860

**POLYURETHANE TIMING**

**AT5 SECTION 5 MM PITCH**

PART NUMBER	PITCH LENGTH (MM)	NO. OF TEETH	PART NUMBER	PITCH LENGTH (MM)	NO. OF TEETH	PART NUMBER	PITCH LENGTH (MM)	NO. OF TEETH	PART NUMBER	PITCH LENGTH (MM)	NO. OF TEETH
25AT5/225	225	45	25AT5/390	390	78	25AT5/600	600	120	25AT5/780	780	156
25AT5/255	255	51	25AT5/420	420	84	25AT5/610	610	122	25AT5/825	825	165
25AT5/280	280	56	25AT5/450	450	90	25AT5/660	660	132	25AT5/860	860	172
25AT5/300	300	60	25AT5/455	455	91	25AT5/710	710	142	25AT5/975	975	195
25AT5/340	340	68	25AT5/500	500	100	25AT5/720	720	144	25AT5/1050	1050	210
25AT5/375	375	75	25AT5/545	545	109	25AT5/750	750	150	25AT5/1500	1500	300

SAMPLE PART # : 12AT10/960

**POLYURETHANE TIMING**

**AT10 SECTION 10 MM PITCH**

PART NUMBER	PITCH LENGTH (MM)	NO. OF TEETH	PART NUMBER	PITCH LENGTH (MM)	NO. OF TEETH	PART NUMBER	PITCH LENGTH (MM)	NO. OF TEETH	PART NUMBER	PITCH LENGTH (MM)	NO. OF TEETH
10AT10/500	500	50	10AT10/800	800	80	10AT10/1100	1100	110	10AT10/1400	1400	140
10AT10/530	530	53	10AT10/840	840	84	10AT10/1150	1150	115	10AT10/1420	1420	142
10AT10/560	560	56	10AT10/890	890	89	10AT10/1200	1200	120	10AT10/1480	1480	148
10AT10/600	600	60	10AT10/920	920	92	10AT10/1210	1210	121	10AT10/1500	1500	150
10AT10/610	610	61	10AT10/960	960	96	10AT10/1250	1250	125	10AT10/1600	1600	160
10AT10/660	660	66	10AT10/980	980	98	10AT10/1280	1280	128	10AT10/1700	1700	170
10AT10/700	700	70	10AT10/1010	1010	101	10AT10/1320	1320	132	10AT10/1800	1800	180
10AT10/730	730	73	10AT10/1050	1050	105	10AT10/1350	1350	135	10AT10/1860	1860	186
10AT10/780	780	78	10AT10/1080	1080	108	10AT10/1360	1360	136	10AT10/1940	1940	194
12AT10/500	500	50	12AT10/800	800	80	12AT10/1100	1100	110	12AT10/1400	1400	140
12AT10/530	530	53	12AT10/840	840	84	12AT10/1150	1150	115	12AT10/1420	1420	142
12AT10/560	560	56	12AT10/890	890	89	12AT10/1200	1200	120	12AT10/1480	1480	148
12AT10/600	600	60	12AT10/920	920	92	12AT10/1210	1210	121	12AT10/1500	1500	150
12AT10/610	610	61	12AT10/960	960	96	12AT10/1250	1250	125	12AT10/1600	1600	160
12AT10/660	660	66	12AT10/980	980	98	12AT10/1280	1280	128	12AT10/1700	1700	170
12AT10/700	700	70	12AT10/1010	1010	101	12AT10/1320	1320	132	12AT10/1800	1800	180
12AT10/730	730	73	12AT10/1050	1050	105	12AT10/1350	1350	135	12AT10/1860	1860	186
12AT10/780	780	78	12AT10/1080	1080	108	12AT10/1360	1360	136	12AT10/1940	1940	194
16AT10/500	500	50	16AT10/800	800	80	16AT10/1100	1100	110	16AT10/1400	1400	140
16AT10/530	530	53	16AT10/840	840	84	16AT10/1150	1150	115	16AT10/1420	1420	142
16AT10/560	560	56	16AT10/890	890	89	16AT10/1200	1200	120	16AT10/1480	1480	148
16AT10/600	600	60	16AT10/920	920	92	16AT10/1210	1210	121	16AT10/1500	1500	150
16AT10/610	610	61	16AT10/960	960	96	16AT10/1250	1250	125	16AT10/1600	1600	160
16AT10/660	660	66	16AT10/980	980	98	16AT10/1280	1280	128	16AT10/1700	1700	170
16AT10/700	700	70	16AT10/1010	1010	101	16AT10/1320	1320	132	16AT10/1800	1800	180
16AT10/730	730	73	16AT10/1050	1050	105	16AT10/1350	1350	135	16AT10/1860	1860	186
16AT10/780	780	78	16AT10/1080	1080	108	16AT10/1360	1360	136	16AT10/1940	1940	194

**AT10 SECTIONS CONTINUED PG 96**

**EXAMPLE SIZING:**

Part Number: 25AT5/455AP

25 = 25 mm Belt Width AT5 = Section Size 455 = 455 mm Pitch Length AP = ALPHA POWER

Part Number: 12AT10/1800 (ALPHA TORQUE)

12 = 12 mm Belt Width AT10 = Section Size 1800 = 1800 mm Pitch Length

Contact an OPTIBELT representative regarding additional sizes, stock availability and pricing.

**EXPEDITED SHIPPING:** Each OPTIBELT warehouse facility cuts timing belts to width for faster order service.



AT10 SECTION 10 MM PITCH

POLYURETHANE TIMING

SAMPLE PART # : 10AT5/390

PART NUMBER	PITCH LENGTH (MM)	NO. OF TEETH	PART NUMBER	PITCH LENGTH (MM)	NO. OF TEETH	PART NUMBER	PITCH LENGTH (MM)	NO. OF TEETH	PART NUMBER	PITCH LENGTH (MM)	NO. OF TEETH
20AT10/500	500	50	20AT10/800	800	80	20AT10/1100	1100	110	20AT10/1400	1400	140
20AT10/530	530	53	20AT10/840	840	84	20AT10/1150	1150	115	20AT10/1420	1420	142
20AT10/560	560	56	20AT10/890	890	89	20AT10/1200	1200	120	20AT10/1480	1480	148
20AT10/600	600	60	20AT10/920	920	92	20AT10/1210	1210	121	20AT10/1500	1500	150
20AT10/610	610	61	20AT10/960	960	96	20AT10/1250	1250	125	20AT10/1600	1600	160
20AT10/660	660	66	20AT10/980	980	98	20AT10/1280	1280	128	20AT10/1700	1700	170
20AT10/700	700	70	20AT10/1010	1010	101	20AT10/1320	1320	132	20AT10/1800	1800	180
20AT10/730	730	73	20AT10/1050	1050	105	20AT10/1350	1350	135	20AT10/1860	1860	186
20AT10/780	780	78	20AT10/1080	1080	108	20AT10/1360	1360	136	20AT10/1940	1940	194
25AT10/500	500	50	25AT10/800	800	80	25AT10/1100	1100	110	25AT10/1400	1400	140
25AT10/530	530	53	25AT10/840	840	84	25AT10/1150	1150	115	25AT10/1420	1420	142
25AT10/560	560	56	25AT10/890	890	89	25AT10/1200	1200	120	25AT10/1480	1480	148
25AT10/600	600	60	25AT10/920	920	92	25AT10/1210	1210	121	25AT10/1500	1500	150
25AT10/610	610	61	25AT10/960	960	96	25AT10/1250	1250	125	25AT10/1600	1600	160
25AT10/660	660	66	25AT10/980	980	98	25AT10/1280	1280	128	25AT10/1700	1700	170
25AT10/700	700	70	25AT10/1010	1010	101	25AT10/1320	1320	132	25AT10/1800	1800	180
25AT10/730	730	73	25AT10/1050	1050	105	25AT10/1350	1350	135	25AT10/1860	1860	186
25AT10/780	780	78	25AT10/1080	1080	108	25AT10/1360	1360	136	25AT10/1940	1940	194
32AT10/500	500	50	32AT10/800	800	80	32AT10/1100	1100	110	32AT10/1400	1400	140
32AT10/530	530	53	32AT10/840	840	84	32AT10/1150	1150	115	32AT10/1420	1420	142
32AT10/560	560	56	32AT10/890	890	89	32AT10/1200	1200	120	32AT10/1480	1480	148
32AT10/600	600	60	32AT10/920	920	92	32AT10/1210	1210	121	32AT10/1500	1500	150
32AT10/610	610	61	32AT10/960	960	96	32AT10/1250	1250	125	32AT10/1600	1600	160
32AT10/660	660	66	32AT10/980	980	98	32AT10/1280	1280	128	32AT10/1700	1700	170
32AT10/700	700	70	32AT10/1010	1010	101	32AT10/1320	1320	132	32AT10/1800	1800	180
32AT10/730	730	73	32AT10/1050	1050	105	32AT10/1350	1350	135	32AT10/1860	1860	186
32AT10/780	780	78	32AT10/1080	1080	108	32AT10/1360	1360	136	32AT10/1940	1940	194
50AT10/500	500	50	50AT10/800	800	80	50AT10/1100	1100	110	50AT10/1400	1400	140
50AT10/530	530	53	50AT10/840	840	84	50AT10/1150	1150	115	50AT10/1420	1420	142
50AT10/560	560	56	50AT10/890	890	89	50AT10/1200	1200	120	50AT10/1480	1480	148
50AT10/600	600	60	50AT10/920	920	92	50AT10/1210	1210	121	50AT10/1500	1500	150
50AT10/610	610	61	50AT10/960	960	96	50AT10/1250	1250	125	50AT10/1600	1600	160
50AT10/660	660	66	50AT10/980	980	98	50AT10/1280	1280	128	50AT10/1700	1700	170
50AT10/700	700	70	50AT10/1010	1010	101	50AT10/1320	1320	132	50AT10/1800	1800	180
50AT10/730	730	73	50AT10/1050	1050	105	50AT10/1350	1350	135	50AT10/1860	1860	186
50AT10/780	780	78	50AT10/1080	1080	108	50AT10/1360	1360	136	50AT10/1940	1940	194

**ALPHA POWER ORDERING:** When ordering ALPHA POWER construction, add "AP" to the end of the part number.  
EXAMPLE: 20AT10/1050 = ALPHA TORQUE part number, 20AT10/1050AP = ALPHA POWER part number

Contact an OPTIBELT representative regarding additional sizes, stock availability and pricing.

**EXPEDITED SHIPPING:** Each OPTIBELT warehouse facility cuts timing belts to width for faster order service.

**EXAMPLE SIZING:**

Part Number: 25AT10/600AP

25 = 25 mm Belt Width AT10 = Section Size 600 = 600 mm Pitch Length AP = ALPHA POWER

Part Number: 32AT10/1280 (ALPHA TORQUE)

32 = 32 mm Belt Width AT10 = Section Size 1280 = 1280 mm Pitch Length



SAMPLE PART # : K564XL025

**POLYURETHANE TIMING**

**XL SECTION .2 IN. PITCH**

PART NUMBER	PITCH LENGTH (IN)	NO. OF TEETH	PART NUMBER	PITCH LENGTH (IN)	NO. OF TEETH	PART NUMBER	PITCH LENGTH (IN)	NO. OF TEETH	PART NUMBER	PITCH LENGTH (IN)	NO. OF TEETH
K60XL025	6	30	K120XL025	12	60	K186XL025	18.6	93	K320XL025	32	160
K70XL025	7	35	K124XL025	12.4	62	K190XL025	19	95	K330XL025	33	165
K76XL025	7.6	38	K126XL025	12.6	63	K200XL025	20	100	K360XL025	36	180
K80XL025	8	40	K128XL025	12.8	64	K210XL025	21	105	K376XL025	37.6	188
K84XL025	8.4	42	K130XL025	13	65	K212XL025	21.2	106	K384XL025	38.4	192
K90XL025	9	45	K136XL025	13.6	68	K220XL025	22	110	K390XL025	39	195
K94XL025	9.4	47	K140XL025	14	70	K230XL025	23	115	K414XL025	41.4	207
K96XL025	9.6	48	K150XL025	15	75	K240XL025	24	120	K460XL025	46	230
K100XL025	10	50	K152XL025	15.2	76	K250XL025	25	125	K480XL025	48	240
K102XL025	10.2	51	K154XL025	15.4	77	K254XL025	25.4	127	K512XL025	51.2	256
K104XL025	10.4	52	K160XL025	16	80	K260XL025	26	130	K550XL025	55	275
K106XL025	10.6	53	K166XL025	16.6	83	K270XL025	27	135	K564XL025	56.4	282
K110XL025	11	55	K168XL025	16.8	84	K290XL025	29	145	K630XL025	63	315
K114XL025	11.4	57	K170XL025	17	85	K300XL025	30	150	K670XL025	67	335
K116XL025	11.6	58	K180XL025	18	90						
K60XL031	6	30	K120XL031	12	60	K186XL031	18.6	93	K320XL031	32	160
K70XL031	7	35	K124XL031	12.4	62	K190XL031	19	95	K330XL031	33	165
K76XL031	7.6	38	K126XL031	12.6	63	K200XL031	20	100	K360XL031	36	180
K80XL031	8	40	K128XL031	12.8	64	K210XL031	21	105	K376XL031	37.6	188
K84XL031	8.4	42	K130XL031	13	65	K212XL031	21.2	106	K384XL031	38.4	192
K90XL031	9	45	K136XL031	13.6	68	K220XL031	22	110	K390XL031	39	195
K94XL031	9.4	47	K140XL031	14	70	K230XL031	23	115	K414XL031	41.4	207
K96XL031	9.6	48	K150XL031	15	75	K240XL031	24	120	K460XL031	46	230
K100XL031	10	50	K152XL031	15.2	76	K250XL031	25	125	K480XL031	48	240
K102XL031	10.2	51	K154XL031	15.4	77	K254XL031	25.4	127	K512XL031	51.2	256
K104XL031	10.4	52	K160XL031	16	80	K260XL031	26	130	K550XL031	55	275
K106XL031	10.6	53	K166XL031	16.6	83	K270XL031	27	135	K564XL031	56.4	282
K110XL031	11	55	K168XL031	16.8	84	K290XL031	29	145	K630XL031	63	315
K114XL031	11.4	57	K170XL031	17	85	K300XL031	30	150	K670XL031	67	335
K116XL031	11.6	58	K180XL031	18	90						
K60XL037	6	30	K102XL037	10.2	51	K128XL037	12.8	64	K168XL037	16.8	84
K70XL037	7	35	K104XL037	10.4	52	K130XL037	13	65	K170XL037	17	85
K76XL037	7.6	38	K106XL037	10.6	53	K136XL037	13.6	68	K180XL037	18	90
K80XL037	8	40	K110XL037	11	55	K140XL037	14	70	K186XL037	18.6	93
K84XL037	8.4	42	K114XL037	11.4	57	K150XL037	15	75	K190XL037	19	95
K90XL037	9	45	K116XL037	11.6	58	K152XL037	15.2	76	K200XL037	20	100
K94XL037	9.4	47	K120XL037	12	60	K154XL037	15.4	77	K210XL037	21	105
K96XL037	9.6	48	K124XL037	12.4	62	K160XL037	16	80			
K100XL037	10	50	K126XL037	12.6	63	K166XL037	16.6	83			

**XL SECTIONS CONTINUED PG#**

**EXAMPLE SIZING:**

Part Number: K128XL031 (K = Belt Construction)  
 128 = 12.8 in. Section Length XL = Section Size Q25 = .25 in. Width  
 Part Number: K76XL037 (K = Belt Construction)  
 76 = 7.6 in. Section Length XL = Section Size Q37 = .37 in. Width

Contact an OPTIBELT representative regarding additional sizes, stock availability and pricing.

**EXPEDITED SHIPPING:** Each OPTIBELT warehouse facility cuts timing belts to width for faster order service.



XL SECTION .2 IN. PITCH

**POLYURETHANE TIMING**

SAMPLE PART # : K384XL037

PART NUMBER	PITCH LENGTH (IN)	NO. OF TEETH	PART NUMBER	PITCH LENGTH (IN)	NO. OF TEETH	PART NUMBER	PITCH LENGTH (IN)	NO. OF TEETH	PART NUMBER	PITCH LENGTH (IN)	NO. OF TEETH
K212XL037	21.2	106	K260XL037	26	130	K360XL037	36	180	K480XL037	48	240
K220XL037	22	110	K270XL037	27	135	K376XL037	37.6	188	K512XL037	51.2	256
K230XL037	23	115	K290XL037	29	145	K384XL037	38.4	192	K550XL037	55	275
K240XL037	24	120	K300XL037	30	150	K390XL037	39	195	K564XL037	56.4	282
K250XL037	25	125	K320XL037	32	160	K414XL037	41.4	207	K630XL037	63	315
K254XL037	25.4	127	K330XL037	33	165	K460XL037	46	230	K670XL037	67	335
K60XL050	6	30	K120XL050	12	60	K186XL050	18.6	93	K320XL050	32	160
K70XL050	7	35	K124XL050	12.4	62	K190XL050	19	95	K330XL050	33	165
K76XL050	7.6	38	K126XL050	12.6	63	K200XL050	20	100	K360XL050	36	180
K80XL050	8	40	K128XL050	12.8	64	K210XL050	21	105	K376XL050	37.6	188
K84XL050	8.4	42	K130XL050	13	65	K212XL050	21.2	106	K384XL050	38.4	192
K90XL050	9	45	K136XL050	13.6	68	K220XL050	22	110	K390XL050	39	195
K94XL050	9.4	47	K140XL050	14	70	K230XL050	23	115	K414XL050	41.4	207
K96XL050	9.6	48	K150XL050	15	75	K240XL050	24	120	K460XL050	46	230
K100XL050	10	50	K152XL050	15.2	76	K250XL050	25	125	K480XL050	48	240
K102XL050	10.2	51	K154XL050	15.4	77	K254XL050	25.4	127	K512XL050	51.2	256
K104XL050	10.4	52	K160XL050	16	80	K260XL050	26	130	K550XL050	55	275
K106XL050	10.6	53	K166XL050	16.6	83	K270XL050	27	135	K564XL050	56.4	282
K110XL050	11	55	K168XL050	16.8	84	K290XL050	29	145	K630XL050	63	315
K114XL050	11.4	57	K170XL050	17	85	K300XL050	30	150	K670XL050	67	335
K116XL050	11.6	58	K180XL050	18	90						

**CUT TO SIZE WIDTHS**

If you need a custom width timing belt, OPTIBELT has you covered. Each OPTIBELT facility can cut custom widths. This means you don't have to wait for a manufactured factory order. If it is stocked it can ship!

Contact an OPTIBELT representative regarding additional sizes, stock availability and pricing.

**EXPEDITED SHIPPING:** Each OPTIBELT warehouse facility cuts timing belts to width for faster order service.

**EXAMPLE SIZING:**

Part Number: K414XL037 (K = Belt Construction)  
414 = 41.4 in. Section Length   XL = Section Size   037 = .37 in. Width  
 Part Number: K390XL050 (K = Belt Construction)  
390 = 39 in. Section Length   XL = Section Size   050 = .5 in. Width



SAMPLE PART # : K510L050

**POLYURETHANE TIMING**

L SECTION .375 IN. PITCH

PART NUMBER	PITCH LENGTH (IN)	NO. OF TEETH	PART NUMBER	PITCH LENGTH (IN)	NO. OF TEETH	PART NUMBER	PITCH LENGTH (IN)	NO. OF TEETH	PART NUMBER	PITCH LENGTH (IN)	NO. OF TEETH
K124L050	12.4	33	K240L050	24	64	K345L050	34.5	92	K450L050	45	120
K150L050	15	40	K255L050	25.5	68	K367L050	36.7	98	K480L050	48	128
K165L050	16.5	44	K270L050	27	72	K375L050	37.5	100	K510L050	51	136
K173L050	17.3	46	K285L050	28.5	76	K390L050	39	104	K525L050	52.5	140
K187L050	18.7	50	K300L050	30	80	K420L050	42	112	K540L050	54	144
K210L050	21	56	K322L050	32.2	86	K427L050	42.7	114	K600L050	60	160
K225L050	22.5	60									
K124L075	12.4	33	K240L075	24	64	K345L075	34.5	92	K450L075	45	120
K150L075	15	40	K255L075	25.5	68	K367L075	36.7	98	K480L075	48	128
K165L075	16.5	44	K270L075	27	72	K375L075	37.5	100	K510L075	51	136
K173L075	17.3	46	K285L075	28.5	76	K390L075	39	104	K525L075	52.5	140
K187L075	18.7	50	K300L075	30	80	K420L075	42	112	K540L075	54	144
K210L075	21	56	K322L075	32.2	86	K427L075	42.7	114	K600L075	60	160
K225L075	22.5	60									
K124L100	12.4	33	K240L100	24	64	K345L100	34.5	92	K450L100	45	120
K150L100	15	40	K255L100	25.5	68	K367L100	36.7	98	K480L100	48	128
K165L100	16.5	44	K270L100	27	72	K375L100	37.5	100	K510L100	51	136
K173L100	17.3	46	K285L100	28.5	76	K390L100	39	104	K525L100	52.5	140
K187L100	18.7	50	K300L100	30	80	K420L100	42	112	K540L100	54	144
K210L100	21	56	K322L100	32.2	86	K427L100	42.7	114	K600L100	60	160
K225L100	22.5	60									
K124L150	12.4	33	K240L150	24	64	K345L150	34.5	92	K450L150	45	120
K150L150	15	40	K255L150	25.5	68	K367L150	36.7	98	K480L150	48	128
K165L150	16.5	44	K270L150	27	72	K375L150	37.5	100	K510L150	51	136
K173L150	17.3	46	K285L150	28.5	76	K390L150	39	104	K525L150	52.5	140
K187L150	18.7	50	K300L150	30	80	K420L150	42	112	K540L150	54	144
K210L150	21	56	K322L150	32.2	86	K427L150	42.7	114	K600L150	60	160
K225L150	22.5	60									

**CUT TO SIZE WIDTHS**

If you need a custom width timing belt, OPTIBELT has you covered. Each OPTIBELT facility can cut custom widths. This means you don't have to wait for a manufactured factory order. If it is stocked it can ship!

**EXAMPLE SIZING:**

Part Number: K510L075 (K = Belt Construction)  
 510 = 51 in. Section Length L = Section Size 075 = .75 in. Width  
 Part Number: K165L150 (K = Belt Construction)  
 165 = 16.5 in. Section Length L = Section Size 150 = 1.5 in. Width

Contact an OPTIBELT representative regarding additional sizes, stock availability and pricing.

**EXPEDITED SHIPPING:** Each OPTIBELT warehouse facility cuts timing belts to width for faster order service.



DT5 SECTION 5 MM PITCH

POLYURETHANE TIMING

SAMPLE PART # : 10DT5/515AP

PART NUMBER	PITCH LENGTH (MM)	NO. OF TEETH	PART NUMBER	PITCH LENGTH (MM)	NO. OF TEETH	PART NUMBER	PITCH LENGTH (MM)	NO. OF TEETH	PART NUMBER	PITCH LENGTH (MM)	NO. OF TEETH
6DT5/300	300	60	6DT5/480	480	96	6DT5/600	600	120	6DT5/815	815	163
6DT5/400	400	80	6DT5/500	500	100	6DT5/620	620	124	6DT5/900	900	180
6DT5/410	410	82	6DT5/515	515	103	6DT5/650	650	130	6DT5/940	940	188
6DT5/450	450	90	6DT5/550	550	110	6DT5/700	700	140	6DT5/1100	1100	220
6DT5/460	460	92	6DT5/590	590	118	6DT5/750	750	150			
8DT5/300	300	60	8DT5/480	480	96	8DT5/600	600	120	8DT5/815	815	163
8DT5/400	400	80	8DT5/500	500	100	8DT5/620	620	124	8DT5/900	900	180
8DT5/410	410	82	8DT5/515	515	103	8DT5/650	650	130	8DT5/940	940	188
8DT5/450	450	90	8DT5/550	550	110	8DT5/700	700	140	8DT5/1100	1100	220
8DT5/460	460	92	8DT5/590	590	118	8DT5/750	750	150			
10DT5/300	300	60	10DT5/480	480	96	10DT5/600	600	120	10DT5/815	815	163
10DT5/400	400	80	10DT5/500	500	100	10DT5/620	620	124	10DT5/900	900	180
10DT5/410	410	82	10DT5/515	515	103	10DT5/650	650	130	10DT5/940	940	188
10DT5/450	450	90	10DT5/550	550	110	10DT5/700	700	140	10DT5/1100	1100	220
10DT5/460	460	92	10DT5/590	590	118	10DT5/750	750	150			
12DT5/300	300	60	12DT5/480	480	96	12DT5/600	600	120	12DT5/815	815	163
12DT5/400	400	80	12DT5/500	500	100	12DT5/620	620	124	12DT5/900	900	180
12DT5/410	410	82	12DT5/515	515	103	12DT5/650	650	130	12DT5/940	940	188
12DT5/450	450	90	12DT5/550	550	110	12DT5/700	700	140	12DT5/1100	1100	220
12DT5/460	460	92	12DT5/590	590	118	12DT5/750	750	150			
16DT5/300	300	60	16DT5/480	480	96	16DT5/600	600	120	16DT5/815	815	163
16DT5/400	400	80	16DT5/500	500	100	16DT5/620	620	124	16DT5/900	900	180
16DT5/410	410	82	16DT5/515	515	103	16DT5/650	650	130	16DT5/940	940	188
16DT5/450	450	90	16DT5/550	550	110	16DT5/700	700	140	16DT5/1100	1100	220
16DT5/460	460	92	16DT5/590	590	118	16DT5/750	750	150			
20DT5/300	300	60	20DT5/480	480	96	20DT5/600	600	120	20DT5/815	815	163
20DT5/400	400	80	20DT5/500	500	100	20DT5/620	620	124	20DT5/900	900	180
20DT5/410	410	82	20DT5/515	515	103	20DT5/650	650	130	20DT5/940	940	188
20DT5/450	450	90	20DT5/550	550	110	20DT5/700	700	140	20DT5/1100	1100	220
20DT5/460	460	92	20DT5/590	590	118	20DT5/750	750	150			
25DT5/300	300	60	25DT5/480	480	96	25DT5/600	600	120	25DT5/815	815	163
25DT5/400	400	80	25DT5/500	500	100	25DT5/620	620	124	25DT5/900	900	180
25DT5/410	410	82	25DT5/515	515	103	25DT5/650	650	130	25DT5/940	940	188
25DT5/450	450	90	25DT5/550	550	110	25DT5/700	700	140	25DT5/1100	1100	220
25DT5/460	460	92	25DT5/590	590	118	25DT5/750	750	150			

**ALPHA POWER ORDERING:** When ordering ALPHA POWER construction, add "AP" to the end of the part number.  
EXAMPLE: 25DT5/815 = ALPHA TORQUE part number, 25DT5/815AP = ALPHA POWER part number

Contact an OPTIBELT representative regarding additional sizes, stock availability and pricing.

**EXPEDITED SHIPPING:** Each OPTIBELT warehouse facility cuts timing belts to width for faster order service.

**EXAMPLE SIZING:**

Part Number: 10DT5/515AP

10 = 10 mm Belt Width DT5 = Section Size 515 = 515 mm Pitch Length AP = ALPHA POWER

Part Number: 20DT5/400 (ALPHA TORQUE)

20 = 20 mm Belt Width DT5 = Section Size 400 = 400 mm Pitch Length



**DT5 SECTION 5 MM PITCH**

**POLYURETHANE TIMING**

SAMPLE PART # : 32DT5/515AP

PART NUMBER	PITCH LENGTH (MM)	NO. OF TEETH	PART NUMBER	PITCH LENGTH (MM)	NO. OF TEETH	PART NUMBER	PITCH LENGTH (MM)	NO. OF TEETH	PART NUMBER	PITCH LENGTH (MM)	NO. OF TEETH
32DT5/300	300	60	32DT5/480	480	96	32DT5/600	600	120	32DT5/815	815	163
32DT5/400	400	80	32DT5/500	500	100	32DT5/620	620	124	32DT5/900	900	180
32DT5/410	410	82	32DT5/515	515	103	32DT5/650	650	130	32DT5/940	940	188
32DT5/450	450	90	32DT5/550	550	110	32DT5/700	700	140	32DT5/1100	1100	220
32DT5/460	460	92	32DT5/590	590	118	32DT5/750	750	150			

**D10 SECTION 10 MM PITCH**

**POLYURETHANE TIMING**

SAMPLE PART # : 20DT10/1600AP

PART NUMBER	PITCH LENGTH (MM)	NO. OF TEETH	PART NUMBER	PITCH LENGTH (MM)	NO. OF TEETH	PART NUMBER	PITCH LENGTH (MM)	NO. OF TEETH	PART NUMBER	PITCH LENGTH (MM)	NO. OF TEETH
10DT10/600	600	60	10DT10/800	800	80	10DT10/1200	1200	120	10DT10/1500	1500	150
10DT10/630	630	63	10DT10/840	840	84	10DT10/1210	1210	121	10DT10/1600	1600	160
10DT10/660	660	66	10DT10/900	900	90	10DT10/1300	1300	130	10DT10/1610	1610	161
10DT10/700	700	70	10DT10/980	980	98	10DT10/1320	1320	132	10DT10/1700	1700	170
10DT10/750	750	75	10DT10/1000	1000	100	10DT10/1420	1420	142	10DT10/1880	1880	188
12DT10/600	600	60	12DT10/800	800	80	12DT10/1200	1200	120	12DT10/1500	1500	150
12DT10/630	630	63	12DT10/840	840	84	12DT10/1210	1210	121	12DT10/1600	1600	160
12DT10/660	660	66	12DT10/900	900	90	12DT10/1300	1300	130	12DT10/1610	1610	161
12DT10/700	700	70	12DT10/980	980	98	12DT10/1320	1320	132	12DT10/1700	1700	170
12DT10/750	750	75	12DT10/1000	1000	100	12DT10/1420	1420	142	12DT10/1880	1880	188
16DT10/600	600	60	16DT10/800	800	80	16DT10/1200	1200	120	16DT10/1500	1500	150
16DT10/630	630	63	16DT10/840	840	84	16DT10/1210	1210	121	16DT10/1600	1600	160
16DT10/660	660	66	16DT10/900	900	90	16DT10/1300	1300	130	16DT10/1610	1610	161
16DT10/700	700	70	16DT10/980	980	98	16DT10/1320	1320	132	16DT10/1700	1700	170
16DT10/750	750	75	16DT10/1000	1000	100	16DT10/1420	1420	142	16DT10/1880	1880	188
20DT10/600	600	60	20DT10/800	800	80	20DT10/1200	1200	120	20DT10/1500	1500	150
20DT10/630	630	63	20DT10/840	840	84	20DT10/1210	1210	121	20DT10/1600	1600	160
20DT10/660	660	66	20DT10/900	900	90	20DT10/1300	1300	130	20DT10/1610	1610	161
20DT10/700	700	70	20DT10/980	980	98	20DT10/1320	1320	132	20DT10/1700	1700	170
20DT10/750	750	75	20DT10/1000	1000	100	20DT10/1420	1420	142	20DT10/1880	1880	188
25DT10/600	600	60	25DT10/800	800	80	25DT10/1200	1200	120	25DT10/1500	1500	150
25DT10/630	630	63	25DT10/840	840	84	25DT10/1210	1210	121	25DT10/1600	1600	160
25DT10/660	660	66	25DT10/900	900	90	25DT10/1300	1300	130	25DT10/1610	1610	161
25DT10/700	700	70	25DT10/980	980	98	25DT10/1320	1320	132	25DT10/1700	1700	170
25DT10/750	750	75	25DT10/1000	1000	100	25DT10/1420	1420	142	25DT10/1880	1880	188

**ALPHA POWER ORDERING:** When ordering ALPHA POWER construction, add "AP" to the end of the part number.  
EXAMPLE: 16DT10/600 = ALPHA TORQUE part number, 16DT10/600AP = ALPHA POWER part number

**EXAMPLE SIZING:**

Part Number: 12DT10/1210 (ALPHA TORQUE)  
12 = 12 mm Belt Width DT10 = Section Size 1210 = 1210 mm Pitch Length  
Part Number: 20DT10/1600AP  
20 = 20 mm Belt Width DT10 = Section Size 1600 = 1600 mm Pitch Length AP = ALPHA POWER

Contact an OPTIBELT representative regarding additional sizes, stock availability and pricing.

**EXPEDITED SHIPPING:** Each OPTIBELT warehouse facility cuts timing belts to width for faster order service.



SAMPLE PART # : 50DT10/630AP

**POLYURETHANE TIMING**

**DT10 SECTION 10 MM PITCH**

PART NUMBER	PITCH LENGTH (MM)	NO. OF TEETH	PART NUMBER	PITCH LENGTH (MM)	NO. OF TEETH	PART NUMBER	PITCH LENGTH (MM)	NO. OF TEETH	PART NUMBER	PITCH LENGTH (MM)	NO. OF TEETH
32DT10/600	600	60	32DT10/800	800	80	32DT10/1200	1200	120	32DT10/1500	1500	150
32DT10/630	630	63	32DT10/840	840	84	32DT10/1210	1210	121	32DT10/1600	1600	160
32DT10/660	660	66	32DT10/900	900	90	32DT10/1300	1300	130	32DT10/1610	1610	161
32DT10/700	700	70	32DT10/980	980	98	32DT10/1320	1320	132	32DT10/1700	1700	170
32DT10/750	750	75	32DT10/1000	1000	100	32DT10/1420	1420	142	32DT10/1880	1880	188
50DT10/600	600	60	50DT10/800	800	80	50DT10/1200	1200	120	50DT10/1500	1500	150
50DT10/630	630	63	50DT10/840	840	84	50DT10/1210	1210	121	50DT10/1600	1600	160
50DT10/660	660	66	50DT10/900	900	90	50DT10/1300	1300	130	50DT10/1610	1610	161
50DT10/700	700	70	50DT10/980	980	98	50DT10/1320	1320	132	50DT10/1700	1700	170
50DT10/750	750	75	50DT10/1000	1000	100	50DT10/1420	1420	142	50DT10/1880	1880	188

**ALPHA POWER ORDERING:** When ordering ALPHA POWER construction, add "AP" to the end of the part number.  
EXAMPLE: 32DT10/1200 = ALPHA TORQUE part number, 32DT10/1200AP = ALPHA POWER part number

**ALPHA SRP CONVEYOR DRIVES**

Custom conveyor drives for specialized manufacturing is a need for more and more businesses. OPTIBELT can manufacture a full range of custom products to customers designed specifications.

ALPHA SRP are custom polyurethane conveyor timing belts that are manufactured from ALPHA POWER & ALPHA TORQUE product constructions.

Minimum order quantities apply. For more details contact an OPTIBELT representative.

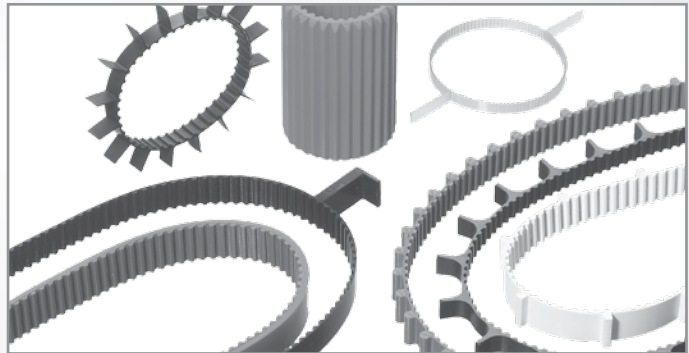

Contact an OPTIBELT representative regarding additional sizes, stock availability and pricing.

**EXPEDITED SHIPPING:** Each OPTIBELT warehouse facility cuts timing belts to width for faster order service.

**EXAMPLE SIZING:**

Part Number: 32DT10/900AP

32 = 32 mm Belt Width DT10 = Section Size 900 = 900 mm Pitch Length AP = ALPHA POWER

Part Number: 50DT10/1610 (ALPHA TORQUE)

50 = 50 mm Belt Width DT10 = Section Size 1610 = 1610 mm Pitch Length





**T5 SECTION 5 MM PITCH**

**POLYURETHANE TIMING**

SAMPLE PART # : 16T5/2700AFX

REF. NUMBER	PITCH LENGTH (MM)	NO. OF TEETH	PART NUMBER	PITCH LENGTH (MM)	NO. OF TEETH	PART NUMBER	PITCH LENGTH (MM)	NO. OF TEETH	PART NUMBER	PITCH LENGTH (MM)	NO. OF TEETH
T5/1500AFX	1500	300	T5/2400AFX	2400	480	T5/3600AFX	3600	720	T5/5400AFX	5400	1080
T5/1600AFX	1600	320	T5/2500AFX	2500	500	T5/3800AFX	3800	760	T5/5600AFX	5600	1120
T5/1700AFX	1700	340	T5/2600AFX	2600	520	T5/4000AFX	4000	800	T5/5800AFX	5800	1160
T5/1800AFX	1800	360	T5/2700AFX	2700	540	T5/4200AFX	4200	840	T5/6000AFX	6000	1200
T5/1900AFX	1900	380	T5/2800AFX	2800	560	T5/4400AFX	4400	880	T5/6200AFX	6200	1240
T5/2000AFX	2000	400	T5/2900AFX	2900	580	T5/4600AFX	4600	920	T5/6400AFX	6400	1280
T5/2100AFX	2100	420	T5/3000AFX	3000	600	T5/4800AFX	4800	960	T5/6600AFX	6600	1320
T5/2200AFX	2200	440	T5/3200AFX	3200	640	T5/5000AFX	5000	1000	T5/6800AFX	6800	1360
T5/2300AFX	2300	460	T5/3400AFX	3400	680	T5/5200AFX	5200	1040	T5/7000AFX	7000	1400

**T10 SECTION 10 MM PITCH**

**POLYURETHANE TIMING**

SAMPLE PART # : 75T10/1900AFX

REF. NUMBER	PITCH LENGTH (MM)	NO. OF TEETH	PART NUMBER	PITCH LENGTH (MM)	NO. OF TEETH	PART NUMBER	PITCH LENGTH (MM)	NO. OF TEETH	PART NUMBER	PITCH LENGTH (MM)	NO. OF TEETH
T10/1500AFX	1500	300	T10/2400AFX	2400	480	T10/3600AFX	3600	720	T10/5400AFX	5400	1080
T10/1600AFX	1600	320	T10/2500AFX	2500	500	T10/3800AFX	3800	760	T10/5600AFX	5600	1120
T10/1700AFX	1700	340	T10/2600AFX	2600	520	T10/4000AFX	4000	800	T10/5800AFX	5800	1160
T10/1800AFX	1800	360	T10/2700AFX	2700	540	T10/4200AFX	4200	840	T10/6000AFX	6000	1200
T10/1900AFX	1900	380	T10/2800AFX	2800	560	T10/4400AFX	4400	880	T10/6200AFX	6200	1240
T10/2000AFX	2000	400	T10/2900AFX	2900	580	T10/4600AFX	4600	920	T10/6400AFX	6400	1280
T10/2100AFX	2100	420	T10/3000AFX	3000	600	T10/4800AFX	4800	960	T10/6600AFX	6600	1320
T10/2200AFX	2200	440	T10/3200AFX	3200	640	T10/5000AFX	5000	1000	T10/6800AFX	6800	1360
T10/2300AFX	2300	460	T10/3400AFX	3400	680	T10/5200AFX	5200	1040	T10/7000AFX	7000	1400

**T20 SECTION 20 MM PITCH**

**POLYURETHANE TIMING**

SAMPLE PART # : 50T20/5000AFX

REF. NUMBER	PITCH LENGTH (MM)	NO. OF TEETH	PART NUMBER	PITCH LENGTH (MM)	NO. OF TEETH	PART NUMBER	PITCH LENGTH (MM)	NO. OF TEETH	PART NUMBER	PITCH LENGTH (MM)	NO. OF TEETH
T20/1500AFX	1500	300	T20/2400AFX	2400	480	T20/3600AFX	3600	720	T20/5400AFX	5400	1080
T20/1600AFX	1600	320	T20/2500AFX	2500	500	T20/3800AFX	3800	760	T20/5600AFX	5600	1120
T20/1700AFX	1700	340	T20/2600AFX	2600	520	T20/4000AFX	4000	800	T20/5800AFX	5800	1160
T20/1800AFX	1800	360	T20/2700AFX	2700	540	T20/4200AFX	4200	840	T20/6000AFX	6000	1200
T20/1900AFX	1900	380	T20/2800AFX	2800	560	T20/4400AFX	4400	880	T20/6200AFX	6200	1240
T20/2000AFX	2000	400	T20/2900AFX	2900	580	T20/4600AFX	4600	920	T20/6400AFX	6400	1280
T20/2100AFX	2100	420	T20/3000AFX	3000	600	T20/4800AFX	4800	960	T20/6600AFX	6600	1320
T20/2200AFX	2200	440	T20/3200AFX	3200	640	T20/5000AFX	5000	1000	T20/6800AFX	6800	1360
T20/2300AFX	2300	460	T20/3400AFX	3400	680	T20/5200AFX	5200	1040	T20/7000AFX	7000	1400

**PRODUCT ORDERING:** Standard widths: 16, 25, 32, 50, 75 & 100 MM Double sided sections: DT5 & DT10

Specialized product such as fabric & foam backings, cleating, mechanical finishes and more are available from the factory. Minimum quantities apply. Contact an OPTIBELT representative for more information.

**CUSTOM PRODUCT:**

- PAZ Fabric
  - DT5, DT10 sections
  - Widths
  - Cleating/Joining Hardware
- Additional customization available.

**SIZES & ORDERING**

Section / Min. Mfg Lengths / Max. Mfg Lengths

- T5 / 1,500 mm / 24,000 MM
- T10 / 1,500 mm / 24,000 MM
- T20 / 1,500 mm / 24,000 MM

Contact customer service for details.

**STANDARD WIDTHS:**

16, 25, 32, 50, 75 & 100 MM



**AT5 SECTION 5 MM PITCH**

**POLYURETHANE TIMING**

SAMPLE PART # : 32AT5/3600AFX

REF. NUMBER	PITCH LENGTH (MM)	NO. OF TEETH	PART NUMBER	PITCH LENGTH (MM)	NO. OF TEETH	PART NUMBER	PITCH LENGTH (MM)	NO. OF TEETH	PART NUMBER	PITCH LENGTH (MM)	NO. OF TEETH
AT5/1500AFX	1500	300	AT5/2400AFX	2400	480	AT5/3600AFX	3600	720	AT5/5400AFX	5400	1080
AT5/1600AFX	1600	320	AT5/2500AFX	2500	500	AT5/3800AFX	3800	760	AT5/5600AFX	5600	1120
AT5/1700AFX	1700	340	AT5/2600AFX	2600	520	AT5/4000AFX	4000	800	AT5/5800AFX	5800	1160
AT5/1800AFX	1800	360	AT5/2700AFX	2700	540	AT5/4200AFX	4200	840	AT5/6000AFX	6000	1200
AT5/1900AFX	1900	380	AT5/2800AFX	2800	560	AT5/4400AFX	4400	880	AT5/6200AFX	6200	1240
AT5/2000AFX	2000	400	AT5/2900AFX	2900	580	AT5/4600AFX	4600	920	AT5/6400AFX	6400	1280
AT5/2100AFX	2100	420	AT5/3000AFX	3000	600	AT5/4800AFX	4800	960	AT5/6600AFX	6600	1320
AT5/2200AFX	2200	440	AT5/3200AFX	3200	640	AT5/5000AFX	5000	1000	AT5/6800AFX	6800	1360
AT5/2300AFX	2300	460	AT5/3400AFX	3400	680	AT5/5200AFX	5200	1040	AT5/7000AFX	7000	1400

**AT10 SECTION 10 MM PITCH**

**POLYURETHANE TIMING**

SAMPLE PART # : 25T10/2900AFX

REF. NUMBER	PITCH LENGTH (MM)	NO. OF TEETH	PART NUMBER	PITCH LENGTH (MM)	NO. OF TEETH	PART NUMBER	PITCH LENGTH (MM)	NO. OF TEETH	PART NUMBER	PITCH LENGTH (MM)	NO. OF TEETH
AT10/1500AFX	1500	300	AT10/2400AFX	2400	480	AT10/3600AFX	3600	720	AT10/5400AFX	5400	1080
AT10/1600AFX	1600	320	AT10/2500AFX	2500	500	AT10/3800AFX	3800	760	AT10/5600AFX	5600	1120
AT10/1700AFX	1700	340	AT10/2600AFX	2600	520	AT10/4000AFX	4000	800	AT10/5800AFX	5800	1160
AT10/1800AFX	1800	360	AT10/2700AFX	2700	540	AT10/4200AFX	4200	840	AT10/6000AFX	6000	1200
AT10/1900AFX	1900	380	AT10/2800AFX	2800	560	AT10/4400AFX	4400	880	AT10/6200AFX	6200	1240
AT10/2000AFX	2000	400	AT10/2900AFX	2900	580	AT10/4600AFX	4600	920	AT10/6400AFX	6400	1280
AT10/2100AFX	2100	420	AT10/3000AFX	3000	600	AT10/4800AFX	4800	960	AT10/6600AFX	6600	1320
AT10/2200AFX	2200	440	AT10/3200AFX	3200	640	AT10/5000AFX	5000	1000	AT10/6800AFX	6800	1360
AT10/2300AFX	2300	460	AT10/3400AFX	3400	680	AT10/5200AFX	5200	1040	AT10/7000AFX	7000	1400

**AT20 SECTION 20 MM PITCH**

**POLYURETHANE TIMING**

SAMPLE PART # : 100AT20/3000AFX

REF. NUMBER	PITCH LENGTH (MM)	NO. OF TEETH	PART NUMBER	PITCH LENGTH (MM)	NO. OF TEETH	PART NUMBER	PITCH LENGTH (MM)	NO. OF TEETH	PART NUMBER	PITCH LENGTH (MM)	NO. OF TEETH
AT20/1500AFX	1500	300	AT20/2400AFX	2400	480	AT20/3600AFX	3600	720	AT20/5400AFX	5400	1080
AT20/1600AFX	1600	320	AT20/2500AFX	2500	500	AT20/3800AFX	3800	760	AT20/5600AFX	5600	1120
AT20/1700AFX	1700	340	AT20/2600AFX	2600	520	AT20/4000AFX	4000	800	AT20/5800AFX	5800	1160
AT20/1800AFX	1800	360	AT20/2700AFX	2700	540	AT20/4200AFX	4200	840	AT20/6000AFX	6000	1200
AT20/1900AFX	1900	380	AT20/2800AFX	2800	560	AT20/4400AFX	4400	880	AT20/6200AFX	6200	1240
AT20/2000AFX	2000	400	AT20/2900AFX	2900	580	AT20/4600AFX	4600	920	AT20/6400AFX	6400	1280
AT20/2100AFX	2100	420	AT20/3000AFX	3000	600	AT20/4800AFX	4800	960	AT20/6600AFX	6600	1320
AT20/2200AFX	2200	440	AT20/3200AFX	3200	640	AT20/5000AFX	5000	1000	AT20/6800AFX	6800	1360
AT20/2300AFX	2300	460	AT20/3400AFX	3400	680	AT20/5200AFX	5200	1040	AT20/7000AFX	7000	1400

**PRODUCT ORDERING:** Standard widths: 16, 25, 32, 50, 75 & 100 MM Double sided sections: DT5 & DT10

Specialized product such as fabric & foam backings, cleating, mechanical finishes and more are available from the factory. Minimum quantities apply. Contact an OPTIBELT representative for more information.

**STANDARD WIDTHS:**  
16, 25, 32, 50, 75 & 100 mm.

**SIZES & ORDERING**  
Section / Min. Mfg Lengths / Max. Mfg Lengths

- AT5 / 1,000 mm / 24,000 MM
- AT10 / 1,000 mm / 24,000 MM
- AT20 / 1,500 mm / 24,000 MM

Contact customer service for details.

**CUSTOM PRODUCT:**

- PAZ Fabric
- DT5, DT10, DT20 sections
- Widths
- Cleating/Joining Hardware

Additional customization available.

# 5M & 8M SECTIONS

STEEL TENSION CORD

optibelt **ALPHA FLEX**

POLYURETHANE TIMING BELTS



ALPHA FLEX  
POLYURETHANE

5M SECTION 5 MM PITCH

## POLYURETHANE TIMING

SAMPLE PART # : 25/5M2600AFX

PART NUMBER	PITCH LENGTH (MM)	NO. OF TEETH	PART NUMBER	PITCH LENGTH (MM)	NO. OF TEETH	PART NUMBER	PITCH LENGTH (MM)	NO. OF TEETH	PART NUMBER	PITCH LENGTH (MM)	NO. OF TEETH
5M/1500AFX	1500	300	5M/2400AFX	2400	480	5M/3600AFX	3600	720	5M/5400AFX	5400	1080
5M/1600AFX	1600	320	5M/2500AFX	2500	500	5M/3800AFX	3800	760	5M/5600AFX	5600	1120
5M/1700AFX	1700	340	5M/2600AFX	2600	520	5M/4000AFX	4000	800	5M/5800AFX	5800	1160
5M/1800AFX	1800	360	5M/2700AFX	2700	540	5M/4200AFX	4200	840	5M/6000AFX	6000	1200
5M/1900AFX	1900	380	5M/2800AFX	2800	560	5M/4400AFX	4400	880	5M/6200AFX	6200	1240
5M/2000AFX	2000	400	5M/2900AFX	2900	580	5M/4600AFX	4600	920	5M/6400AFX	6400	1280
5M/2100AFX	2100	420	5M/3000AFX	3000	600	5M/4800AFX	4800	960	5M/6600AFX	6600	1320
5M/2200AFX	2200	440	5M/3200AFX	3200	640	5M/5000AFX	5000	1000	5M/6800AFX	6800	1360
5M/2300AFX	2300	460	5M/3400AFX	3400	680	5M/5200AFX	5200	1040	5M/7000AFX	7000	1400

STANDARD WIDTHS: 15, 25, 50, 75 & 100 MM

8M SECTION 8 MM PITCH

## POLYURETHANE TIMING

SAMPLE PART # : 50/8M1704AFX

PART NUMBER	PITCH LENGTH (MM)	NO. OF TEETH	PART NUMBER	PITCH LENGTH (MM)	NO. OF TEETH	PART NUMBER	PITCH LENGTH (MM)	NO. OF TEETH	PART NUMBER	PITCH LENGTH (MM)	NO. OF TEETH
8M/1504AFX	1504	188	8M/2400AFX	2400	300	8M/3600AFX	3600	450	8M/5400AFX	5400	675
8M/1600AFX	1600	200	8M/2504AFX	2504	313	8M/3800AFX	3800	475	8M/5600AFX	5600	700
8M/1704AFX	1704	213	8M/2600AFX	2600	325	8M/4000AFX	4000	500	8M/5800AFX	5800	725
8M/1800AFX	1800	225	8M/2704AFX	2700	338	8M/4200AFX	4200	525	8M/6000AFX	6000	750
8M/1904AFX	1904	238	8M/2800AFX	2800	350	8M/4400AFX	4400	550	8M/6200AFX	6200	775
8M/2000AFX	2000	250	8M/2904AFX	2904	363	8M/4600AFX	4600	575	8M/6400AFX	6400	800
8M/2104AFX	2104	263	8M/3000AFX	3000	375	8M/4800AFX	4800	600	8M/6600AFX	6600	825
8M/2200AFX	2200	275	8M/3200AFX	3200	400	8M/5000AFX	5000	625	8M/6800AFX	6800	850
8M/2304AFX	2304	288	8M/3400AFX	3400	425	8M/5200AFX	5200	650	8M/7000AFX	7000	875

STANDARD WIDTHS: 20, 25, 30, 50, 85, 100MM

### EXAMPLE SIZING:

Part Number: 25/5M2600AFX (AFX = ALPHA FLEX Belt Construction)  
25 = 25 mm Belt Width 5M = Section Size 2600 = 2600 mm Pitch Length

Part Number: 50/8M1704AFX (AFX = ALPHA FLEX Belt Construction)  
50 = 50 mm Belt Width 8M = Section Size 1704 = 1704 mm Pitch Length

## CUSTOMIZED OPTIONS : MECHANICAL FINISHES

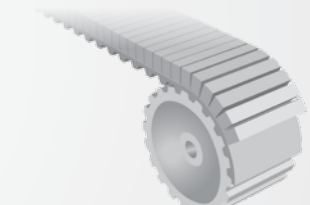
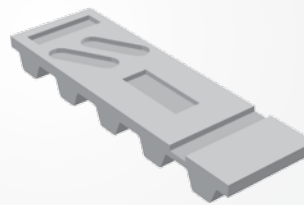
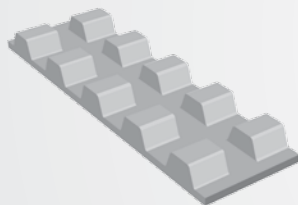

Additional options available. Contact an OPTIBELT representative for further details.

### Need Help?

Contact OPTIBELT customer service.  
Our friendly staff is here to assist you.  
TOLL FREE: 800-292-6081  
E-MAIL: [info@optibelt-usa.com](mailto:info@optibelt-usa.com)

### SIZES & ORDERING

Section / Min. Mfg Lengths / Max. Mfg Lengths

- 5M / 1,500 mm / 24,000 MM
- 8M / 1,500 mm / 24,000 MM

Contact customer service for details.

### CUSTOM PRODUCT:

- PAZ Fabric
  - Widths
  - Cleating/Joining Hardware
- Additional customization available.



14M SECTION 14 MM PITCH

**POLYURETHANE TIMING**

SAMPLE PART # : 85/14M4494AFX

PART NUMBER	PITCH LENGTH (MM)	NO. OF TEETH	PART NUMBER	PITCH LENGTH (MM)	NO. OF TEETH	PART NUMBER	PITCH LENGTH (MM)	NO. OF TEETH	PART NUMBER	PITCH LENGTH (MM)	NO. OF TEETH
14M/1512AFX	1512	108	14M/2898AFX	2898	207	14M/4298AFX	4298	307	14M/5698AFX	5698	407
14M/1596AFX	1596	114	14M/2996AFX	2996	214	14M/4396AFX	4396	314	14M/5796AFX	5796	414
14M/1696AFX	1694	121	14M/3094AFX	3094	221	14M/4494AFX	4494	321	14M/5894AFX	5894	421
14M/1750AFX	1750	125	14M/3150AFX	3150	225	14M/4550AFX	4550	325	14M/5950AFX	5950	425
14M/1806AFX	1806	129	14M/3206AFX	3206	229	14M/4606AFX	4606	329	14M/6006AFX	6006	429
14M/1904AFX	1904	136	14M/3304AFX	3304	236	14M/4704AFX	4704	336	14M/6104AFX	6104	436
14M/2002AFX	2002	143	14M/3402AFX	3402	243	14M/4802AFX	4802	343	14M/6202AFX	6202	443
14M/2100AFX	2100	150	14M/3500AFX	3500	250	14M/4900AFX	4900	350	14M/6300AFX	6300	450
14M/2198AFX	2198	157	14M/3598AFX	3598	257	14M/4998AFX	4998	357	14M/6398AFX	6398	457
14M/2296AFX	2296	164	14M/3696AFX	3696	264	14M/5096AFX	5096	364	14M/6496AFX	6496	464
14M/2394AFX	2394	171	14M/3794AFX	3794	271	14M/5194AFX	5194	371	14M/6594AFX	6594	471
14M/2450AFX	2450	175	14M/3850AFX	3850	275	14M/5250AFX	5250	375	14M/6650AFX	6650	475
14M/2506AFX	2506	179	14M/3906AFX	3906	279	14M/5306AFX	5306	379	14M/6706AFX	6706	479
14M/2604AFX	2604	186	14M/4004AFX	4004	286	14M/5404AFX	5404	386	14M/6804AFX	6804	486
14M/2702AFX	2702	193	14M/4102AFX	4102	293	14M/5502AFX	5502	393	14M/6902AFX	6902	493
14M/2800AFX	2800	200	14M/4200AFX	4200	300	14M/5600AFX	5600	400	14M/7000AFX	7000	500

STANDARD WIDTHS: 25, 40, 55, 85, 100 MM

**EXAMPLE SIZING:**

Part Number: 85/14M4494AFX (AFX = ALPHA FLEX Belt Construction)  
85 = 85 mm Belt Width 14M = Section Size 4949 = 4949 mm Pitch Length

Part Number: 50/14M2198AFX (AFX = ALPHA FLEX Belt Construction)  
50 = 50 mm Belt Width 14M = Section Size 2198 = 2198 mm Pitch Length

**CUSTOMIZED OPTIONS : MECHANICAL FINISHES**

OPTIBELT's state-of-the-art manufacturing facilities allow the capabilities to manufacture custom polyurethane belts suited to our customers specific needs. These include:

- Ground belt top surface
- Ground belt width
- Machined grooves top and bottom
- Remove individual teeth
- Pierce toothed belts
- Separate coatings
- Milled grooves in the belt top surface/coating
- Cleating options available

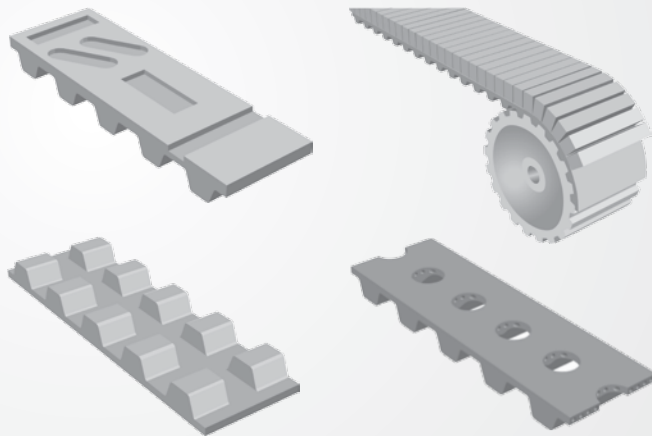

Additional options available. Contact an OPTIBELT representative for further details.

**SIZES & ORDERING**

Section / Min. Mfg Lengths / Max. Mfg Lengths

- 5M / 1,500 mm / 24,000 MM
- 8M / 1,500 mm / 24,000 MM

Contact customer service for details.

**CUSTOM PRODUCT:**

- PAZ Fabric
- Widths
- Cleating/Joining Hardware

Additional customization available.

**Need Help?**

Contact OPTIBELT customer service.  
Our friendly staff is here to assist you.  
TOLL FREE: 800-292-6081  
E-MAIL: info@optibelt-usa.com



**ALPHA LINEAR**  
POLYURETHANE

SAMPLE PART # : XL037-AR

**POLYURETHANE TIMING**

**XL SECTION** .2 IN. PITCH

STEEL	ARAMID	TENSION CORD	
PROFILE WIDTH-CORD	PROFILE WIDTH-CORD	PITCH (IN)	BELT WIDTH (IN)
XL025-ST	XL025-AR	.200	.250
XL031-ST	XL031-AR	.200	.313
XL037-ST	XL037-AR	.200	.375

STEEL	ARAMID	TENSION CORD	
PROFILE WIDTH-CORD	PROFILE WIDTH-CORD	PITCH (IN)	BELT WIDTH (IN)
XL050-ST	XL050-AR	.200	.500
XL075-ST	XL075-AR	.200	.750
XL100-ST	XL100-AR	.200	1

SAMPLE PART # : L100-ST

**L SECTION** .375 IN. PITCH

L037-ST	L037-AR	.375	.375
L050-ST	L050-AR	.375	.500
L075-ST	L075-AR	.375	.750

L100-ST	L100-AR	.375	1
L150-ST	L150-AR	.375	1.50
L200-ST	L200-AR	.375	2

SAMPLE PART # : L100-ST

**H SECTION** .5 IN. PITCH

H050-ST	H050-AR	.500	.500
H075-ST	H075-AR	.500	.750
H100-ST	H100-AR	.500	1
H150-ST	H150-AR	.500	1.5

L100-ST	L100-AR	.375	1
L150-ST	L150-AR	.375	1.50
L200-ST	L200-AR	.375	2

SAMPLE PART # : L100-ST

**XH SECTION** .875 IN. PITCH

XH100-ST	XH100-AR	.875	1
XH200-ST	XH200-AR	.875	2

XH300-ST	XH300-AR	.875	3
XH500-ST	XH500-AR	.875	5

ST = Steel Cord AR = Aramid Cord

SAMPLE PART # : 5M10-ST

**POLYURETHANE TIMING**

**5M SECTION** 5 MM PITCH

STEEL	ARAMID	TENSION CORD	
PROFILE WIDTH-CORD	PROFILE WIDTH-CORD	PITCH (MM)	BELT WIDTH (MM)
5M10-ST	5M10-AR	5	10
5M15-ST	5M15-AR	5	15

STEEL	ARAMID	TENSION CORD	
PROFILE WIDTH-CORD	PROFILE WIDTH-CORD	PITCH (MM)	BELT WIDTH (MM)
5M25-ST	5M25-AR	5	25
5M50-ST	5M50-AR	5	50

SAMPLE PART # : 8M85-ST

**8M SECTION** 8 MM PITCH

8M20-ST	8M20-AR	8	20
8M25-ST	8M25-AR	8	25
8M30-ST	8M30-AR	8	30

8M50-ST	8M50-AR	8	50
8M85-ST	8M85-AR	8	85

SAMPLE PART # : 14M55-ST

**14M SECTION** 14 MM PITCH

14M25-ST	14M25-AR	14	25
14M40-ST	14M40-AR	14	40

14M55-ST	14M55-AR	14	55
14M85-ST	14M85-AR	14	85

ST = Steel Cord AR = Aramid Cord

**EXAMPLE SIZING:**

Part Number: L100-ST

L = Section Size 100 = 1 in. Belt Width ST = Steel Cord

Part Number: 5M15-AR

5M = Section Size 15 = 15 mm Belt Width AR = Aramid Cord

**Need Help?**

Contact OPTIBELT customer service.  
Our friendly staff is here to assist you.  
TOLL FREE: 800-292-6081  
E-MAIL: info@optibelt-usa.com

**CUSTOM PRODUCT:**

- Joined Endless
- Belt Widths
- Cleating/Joining Hardware

Additional customization available.

**STANDARD ROLL LENGTH:**

164 FT. / 50 M

**JOINED ENDLESS:**

Linear belts can be joined endless. Contact an OPTIBELT representative for more information.



**T5 SECTION 5 MM PITCH**

**POLYURETHANE TIMING**

SAMPLE PART # : 25T5-ST

STEEL		ARAMID		TENSION CORD	
PROFILE WIDTH-CORD	PROFILE WIDTH-CORD	PITCH (MM)	BELT WIDTH (MM)	PROFILE WIDTH-CORD	PROFILE WIDTH-CORD
10T5-ST	10T5-AR	5	10	10T5-ST	10T5-AR
16T5-ST	16T5-AR	5	16	16T5-ST	16T5-AR
25T5-ST	25T5-AR	5	25	25T5-ST	25T5-AR
32T5-ST	32T5-AR	5	32	32T5-ST	32T5-AR

STEEL		ARAMID		TENSION CORD	
PROFILE WIDTH-CORD	PROFILE WIDTH-CORD	PITCH (MM)	BELT WIDTH (MM)	PROFILE WIDTH-CORD	PROFILE WIDTH-CORD
50T5-ST	50T5-AR	5	50	50T5-ST	50T5-AR
75T5-ST	75T5-AR	5	75	75T5-ST	75T5-AR
100T5-ST	100T5-AR	5	100	100T5-ST	100T5-AR

**T10 SECTION 10 MM PITCH**

SAMPLE PART # : 50T10-AR

10T10-ST	10T10-AR	10	10	10T10-ST	10T10-AR
16T10-ST	16T10-AR	10	16	16T10-ST	16T10-AR
25T10-ST	25T10-AR	10	25	25T10-ST	25T10-AR
32T10-ST	32T10-AR	10	32	32T10-ST	32T10-AR
40T10-ST	40T10-AR	10	40	40T10-ST	40T10-AR

50T10-ST	50T10-AR	10	50	50T10-ST	50T10-AR
75T10-ST	75T10-AR	10	75	75T10-ST	75T10-AR
100T10-ST	100T10-AR	10	100	100T10-ST	100T10-AR
150T10-ST	150T10-AR	10	150	150T10-ST	150T10-AR

**T20 SECTION 10 MM PITCH**

SAMPLE PART # : 50T20-AR

25T20-ST	25T20-AR	20	25	25T20-ST	25T20-AR
32T20-ST	32T20-AR	20	32	32T20-ST	32T20-AR
50T20-ST	50T20-AR	20	50	50T20-ST	50T20-AR

75T20-ST	75T20-AR	20	75	75T20-ST	75T20-AR
100T20-ST	100T20-AR	20	100	100T20-ST	100T20-AR
150T20-ST	150T20-AR	20	150	150T20-ST	150T20-AR

ST = Steel Cord AR = Aramid Cord

**AT5 SECTION 5 MM PITCH**

**POLYURETHANE TIMING**

SAMPLE PART # : 10AT5-AR

STEEL		ARAMID		TENSION CORD	
PROFILE WIDTH-CORD	PROFILE WIDTH-CORD	PITCH (MM)	BELT WIDTH (MM)	PROFILE WIDTH-CORD	PROFILE WIDTH-CORD
10AT5-ST	10AT5-AR	5	10	10AT5-ST	10AT5-AR
16AT5-ST	16AT5-AR	5	16	16AT5-ST	16AT5-AR
25AT5-ST	25AT5-AR	5	25	25AT5-ST	25AT5-AR
32AT5-ST	32AT5-AR	5	32	32AT5-ST	32AT5-AR

STEEL		ARAMID		TENSION CORD	
PROFILE WIDTH-CORD	PROFILE WIDTH-CORD	PITCH (MM)	BELT WIDTH (MM)	PROFILE WIDTH-CORD	PROFILE WIDTH-CORD
50AT5-ST	50AT5-AR	5	50	50AT5-ST	50AT5-AR
75AT5-ST	75AT5-AR	5	75	75AT5-ST	75AT5-AR
100AT5-ST	100AT5-AR	5	100	100AT5-ST	100AT5-AR

**AT10 SECTION 10 MM PITCH**

SAMPLE PART # : 75AT10-AR

16AT10-ST	16AT10-AR	10	16	16AT10-ST	16AT10-AR
25AT10-ST	25AT10-AR	10	25	25AT10-ST	25AT10-AR
32AT10-ST	32AT10-AR	10	32	32AT10-ST	32AT10-AR
50AT10-ST	50AT10-AR	10	50	50AT10-ST	50AT10-AR

75AT10-ST	75AT10-AR	10	75	75AT10-ST	75AT10-AR
100AT10-ST	100AT10-AR	10	100	100AT10-ST	100AT10-AR
150AT10-ST	150AT10-AR	10	150	150AT10-ST	150AT10-AR

**AT20 SECTION 10 MM PITCH**

SAMPLE PART # : 50AT20-ST

25AT20-ST	25AT20-AR	20	25	25AT20-ST	25AT20-AR
32AT20-ST	32AT20-AR	20	32	32AT20-ST	32AT20-AR
50AT20-ST	50AT20-AR	20	50	50AT20-ST	50AT20-AR

75AT20-ST	75AT20-AR	20	75	75AT20-ST	75AT20-AR
100AT20-ST	100AT20-AR	20	100	100AT20-ST	100AT20-AR
150AT20-ST	150AT20-AR	20	150	150AT20-ST	150AT20-AR

ST = Steel Cord AR = Aramid Cord

**EXAMPLE SIZING:**

Part Number: 50T10-AR

50 = 1 mm Belt Width T10 = Section Size AR = Aramid Cord

Part Number: 50AT20-ST

50 = 50 mm Belt Width AT20 = Section Size ST = Steel Cord

**ALPHA LINEAR F** Contact an OPTIBELT representative for more information.

**SECTIONS: F2, F2.5, F3**

**STANDARD ROLL LENGTH:**  
164 FT. / 50 M

**JOINED ENDLESS:**

Linear belts can be joined endless. Minimum lengths apply to aramid cord belts (1000 MM) (600MM, T5, T10, AT5, AT10).

**INVENTORY/STOCKING:**

Due to the specialized nature and customization options available Alpha Linear Products are a non-stocking item.

**CUSTOM PRODUCT:**

- Joined Endless
- Belt Widths
- Cleating/Joining Hardware

Additional customization available.



OPEN-ENDED  
**ZR**

SAMPLE PART # : NE-L075 GLASS

**OPEN-ENDED TIMING**

**XL SECTION** .2 IN. PITCH

STEEL		FIBERGLASS		TENSION CORD	
PROFILE WIDTH-CORD	PROFILE WIDTH-CORD	BELT WIDTH (IN)	ROLL LENGTH (FT)	PROFILE WIDTH-CORD	PROFILE WIDTH-CORD
XL025 STEEL	XL025 GLASS	.250	98	XL025 STEEL	XL025 GLASS
XL031 STEEL	XL031 GLASS	.313	98	XL031 STEEL	XL031 GLASS

STEEL		FIBERGLASS		TENSION CORD	
PROFILE WIDTH-CORD	PROFILE WIDTH-CORD	BELT WIDTH (IN)	ROLL LENGTH (FT)	PROFILE WIDTH-CORD	PROFILE WIDTH-CORD
XL037 STEEL	XL037 GLASS	.375	98	XL037 STEEL	XL037 GLASS
XL050 STEEL	XL050 GLASS	.500	98	XL050 STEEL	XL050 GLASS

SAMPLE PART # : NE-L100-ST

**L SECTION** .375 IN. PITCH

L037 STEEL	L037 GLASS	.375	98	L037 STEEL	L037 GLASS
L050 STEEL	L050 GLASS	.500	98	L050 STEEL	L050 GLASS

L075 STEEL	L075 GLASS	.750	98	L075 STEEL	L075 GLASS
L100 STEEL	L100 GLASS	1	98	L100 STEEL	L100 GLASS

SAMPLE PART # : NE-H200-ST

**H SECTION** .5 IN. PITCH

H050 STEEL	H050 GLASS	.500	98	H050 STEEL	H050 GLASS
H075 STEEL	H075 GLASS	.500	98	H075 STEEL	H075 GLASS
H100 STEEL	H100 GLASS	.500	98	H100 STEEL	H100 GLASS

H150 STEEL	H150 GLASS	.375	98	H150 STEEL	H150 GLASS
H200 STEEL	H200 GLASS	.375	98	H200 STEEL	H200 GLASS

STEEL = Steel Cord GLASS = Fiberglass Cord

SAMPLE PART # : NE-3M06-ST

**OPEN-ENDED TIMING**

**3M SECTION** 3 MM PITCH

STEEL		FIBERGLASS		TENSION CORD	
PROFILE WIDTH-CORD	PROFILE WIDTH-CORD	BELT WIDTH (IN)	ROLL LENGTH (FT)	PROFILE WIDTH-CORD	PROFILE WIDTH-CORD
3M06 STEEL	3M06 GLASS	5	98	3M06 STEEL	3M06 GLASS
3M09 STEEL	3M09 GLASS	5	98	3M09 STEEL	3M09 GLASS

STEEL		FIBERGLASS		TENSION CORD	
PROFILE WIDTH-CORD	PROFILE WIDTH-CORD	BELT WIDTH (IN)	ROLL LENGTH (FT)	PROFILE WIDTH-CORD	PROFILE WIDTH-CORD
3M15 STEEL	3M15 GLASS	5	98	3M15 STEEL	3M15 GLASS

SAMPLE PART # : NE-5M09-ST

**5M SECTION** 5 MM PITCH

5M06 STEEL	5M06 GLASS	6	98	5M06 STEEL	5M06 GLASS
5M09 STEEL	5M09 GLASS	9	98	5M09 STEEL	5M09 GLASS

5M15 STEEL	5M15 GLASS	15	98	5M15 STEEL	5M15 GLASS
5M25 STEEL	5M25 GLASS	25	98	5M25 STEEL	5M25 GLASS

SAMPLE PART # : NE-8M30 GLASS

**8M SECTION** 8 MM PITCH

8M10 STEEL	8M10 GLASS	10	98	8M10 STEEL	8M10 GLASS
8M15 STEEL	8M15 GLASS	15	98	8M15 STEEL	8M15 GLASS
8M20 STEEL	8M20 GLASS	20	98	8M20 STEEL	8M20 GLASS

8M30 STEEL	8M30 GLASS	30	98	8M30 STEEL	8M30 GLASS
8M50 STEEL	8M50 GLASS	50	98	8M50 STEEL	8M50 GLASS
8M85 STEEL	8M85 GLASS	85	98	8M85 STEEL	8M85 GLASS

SAMPLE PART # : 14M55-ST

**14M SECTION** 14 MM PITCH

14M25 STEEL	14M25 GLASS	25	98	14M25 STEEL	14M25 GLASS
14M40 STEEL	14M40 GLASS	40	98	14M40 STEEL	14M40 GLASS

14M55 STEEL	14M55 GLASS	55	98	14M55 STEEL	14M55 GLASS
14M85 STEEL	14M85 GLASS	85	98	14M85 STEEL	14M85 GLASS

STEEL = Steel Cord GLASS = Fiberglass Cord

**EXAMPLE SIZING:**

Part Number: L075 GLASS

Part Number: 5M09-ST

L = Section Size 075 = .75 in. Belt Width GLASS = Fiberglass Cord

5M = Section Size 09 = 9 in. Belt Width ST = Steel Cord

**ZR LINEAR FEATURES:**

- High tensile strength
- Angular misalignment max. 0.67° (dependent on the width)
- Maintenance free

- Approved worldwide
- For low loading
- Sections standardized according to ISO 5296 / ISO 5294
- Standard roll length 98 ft. (30 m)

**PRODUCT APPLICATIONS:**

- Automatic gates & doors
- Robotic Automation
- Positioning Drives

**CUSTOM PRODUCT:**

- Belt Widths
- Cleating/Joining Hardware

Additional customization available.

**INVENTORY/STOCKING:**

Due to the specialized nature and customization options available Alpha Linear Products are a non-stocking item.

**STANDARD ROLL LENGTH:**

164 FT. / 50 M



**optibelt CP**  
CLAMPING PLATES

**ALUMINUM CONSTRUCTION**

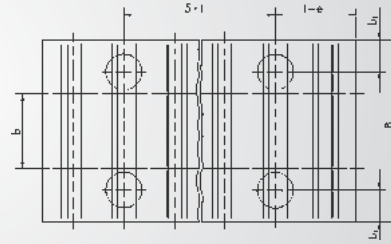
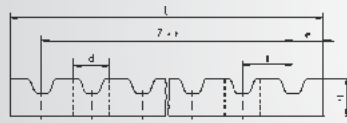

**CP PLATES**  
LINEAR TIMING

PART NUMBER	PITCH (T) (MM)	BELT WIDTH (B) (MM)	B (MM)	b <sub>1</sub> (MM)	L (MM)	e (MM)	H (MM)	d (MM)	WEIGHT (LBS)	WEIGHT (KG)
CP-XL025	5.08	6.35	25.5	6	42.5	3.5	8	5.5	0.044	0.02
CP-XL037	5.08	9.53	28.5	6	42.5	3.5	8	5.5	0.055	0.025
CP-XL050	5.08	12.7	32	6	42.5	3.5	8	5.5	0.06	0.027
CP-XL075	5.08	19.05	38	6	42.5	3.5	8	5.5	0.071	0.032
CP-XL10	5.08	25.4	45	6	42.5	3.5	8	5.5	0.084	0.038
CP-L037	9.525	9.53	36	8	76.6	5	15	9	0.209	0.095
CP-L050	9.525	12.7	39	8	76.6	5	15	9	0.229	0.104
CP-L075	9.525	19.05	45	8	76.6	5	15	9	0.267	0.121
CP-L100	9.525	25.4	51.5	8	76.6	5	15	9	0.309	0.14
CP-L150	9.525	38.1	64	8	76.6	5	15	9	0.39	0.177
CP-L200	9.525	50.8	77	8	76.6	5	15	9	0.474	0.215
CP-H050	12.7	12.7	45	10	106.9	9	22	11	0.11	0.05
CP-H075	12.7	19.05	51	10	106.9	9	22	11	0.165	0.075
CP-H100	12.7	25.4	57.5	10	106.9	9	22	11	0.22	0.1
CP-H150	12.7	38.1	70	10	106.9	9	22	11	0.331	0.15
CP-H200	12.7	50.8	83	10	106.9	9	22	11	0.441	0.2
CP-H300	12.7	76.2	108	10	106.9	9	22	11	0.661	0.3
CP-H400	12.7	101.6	134	10	106.9	9	22	11	0.882	0.4
CP-5M06	5	6	25	6	41.8	3.2	8	5.5	0.033	0.015
CP-5M09	5	9	28	6	41.8	3.2	8	5.5	0.04	0.018
CP-5M15	5	15	34	6	41.8	3.2	8	5.5	0.049	0.022
CP-5M25	5	25	44	6	41.8	3.2	8	5.5	0.066	0.03
CP-8M10	8	10	35	8	66	5	15	9	0.165	0.075
CP-8M15	8	15	40	8	66	5	15	9	0.187	0.085
CP-8M20	8	20	45	8	66	5	15	9	0.22	0.1
CP-8M30	8	30	55	8	66	5	15	9	0.265	0.12
CP-8M50	8	50	75	8	66	5	15	9	0.375	0.17
CP-8M85	8	85	110	8	66	5	15	9	0.551	0.25

CLAMPING PLATES CONT. PG#

**EXAMPLE SIZING:**

Part Number: CP-XL050 (CP = Product Code)  
 XL = Section Size 050 = .5 in. Width  
 Part Number: CP-H150 (CP = Product Code)  
 H = Section Size 150 = 1.5 in. Width

Part Number: CP-5M15 (CP = Product Code)  
 5M = Section Size 15 = 15 mm Width  
 Part Number: CP-14M25 (CP = Product Code)  
 14M = Section Size M25 = 25 mm. Width

**Need Help?**

Contact OPTIBELT customer service.  
 Our friendly staff is here to assist you.  
 TOLL FREE: 800-292-6081  
 E-MAIL: info@optibelt-usa.com



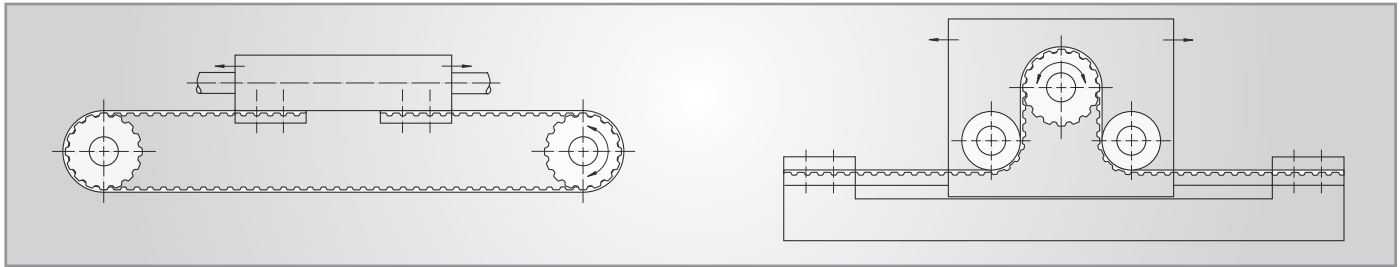

PART NUMBER	PITCH (T) (MM)	BELT WIDTH (B) (MM)	B (MM)	b <sub>1</sub> (MM)	L (MM)	e (MM)	H (MM)	d (MM)	WEIGHT (LBS)	WEIGHT (KG)
CP-14M25	14	25	56	10	116	9	22	11	0.694	0.315
CP-14M40	14	40	71	10	116	9	22	11	0.893	0.405
CP-14M55	14	55	86	10	116	9	22	11	1.091	0.495
CP-14M85	14	85	116	10	116	9	22	11	1.896	0.86
CP-14M115	14	115	146	10	116	9	22	11	2.635	1.195
CP-6T5	5	6	25	6	41.8	3.2	8	5.5	0.044	0.02
CP-10T5	5	10	29	6	41.8	3.2	8	5.5	0.055	0.025
CP-16T5	5	16	35	6	41.8	3.2	8	5.5	0.066	0.03
CP-25T5	5	25	44	6	41.8	3.2	8	5.5	0.079	0.036
CP-32T5	5	32	51	6	41.8	3.2	8	5.5	0.093	0.042
CP-50T5	5	50	69	6	41.8	3.2	8	5.5	0.112	0.051
CP-16T10	10	16	41	8	80	5	15	9	0.254	0.115
CP-25T10	10	25	50	8	80	5	15	9	0.309	0.14
CP-32T10	10	32	57	8	80	5	15	9	0.353	0.16
CP-50T10	10	50	75	8	80	5	15	9	0.474	0.215
CP-75T10	10	75	100	8	80	5	15	9	0.639	0.29
CP-100T10	10	100	125	8	80	5	15	9	0.816	0.37
CP-25T20	20	25	56	10	160	10	20	11	0.849	0.385
CP-32T20	20	32	65	10	160	10	20	11	0.992	0.45
CP-50T20	20	50	81	10	160	10	20	11	1.257	0.57
CP-75T20	20	75	106	10	160	10	20	11	1.664	0.755
CP-100T20	20	100	132	10	160	10	20	11	2.072	0.94

**CP PLATES**  
LINEAR TIMING

<p><b>Need Help?</b> Contact OPTIBELT customer service. Our friendly staff is here to assist you. TOLL FREE: 800-292-6081 E-MAIL: <a href="mailto:info@optibelt-usa.com">info@optibelt-usa.com</a></p>	<p><b>EXAMPLE SIZING:</b> Part Number: CP-10T5 (CP = Product Code) 10 = 10 mm Width I5 = Section Size Part Number: CP-25T5 (CP = Product Code) 25 = 25 mm Width I5 = Section Size</p>	<p>Part Number: CP-75T10 (CP = Product Code) 75 = 75 mm Width I10 = Section Size Part Number: CP-50T20 (CP = Product Code) 50 = 50 mm Width I20 = Section Size</p>
------------------------------------------------------------------------------------------------------------------------------------------------------------------------------------------------------------------------	-------------------------------------------------------------------------------------------------------------------------------------------------------------------------------------------------------	--------------------------------------------------------------------------------------------------------------------------------------------------------------------------------



**KS SHEAVES**  
SHEAVES & BUSHINGS

**3V SECTION SHEAVES**

1 GROOVE			2 GROOVE			3 GROOVE			4 GROOVE		
PART NUMBER	WEIGHT (LBS)	BUSHING	PART NUMBER	WEIGHT (LBS)	BUSHING	PART NUMBER	WEIGHT (LBS)	BUSHING	PART NUMBER	WEIGHT (LBS)	BUSHING
1/3V220	0.7	JA	2/3V220	0.9	JA	3/3V250	1.1	JA	4/3V260	1.4	JA
1/3V230	0.7	JA	2/3V230	0.9	JA	3/3V260	1.2	JA	4/3V280	1.7	JA
1/3V250	0.8	JA	2/3V250	1.0	JA	3/3V280	1.3	JA	4/3V300	1.9	SH
1/3V260	0.6	JA	2/3V260	0.8	JA	3/3V300	1.5	SH	4/3V310	2.0	SH
1/3V280	0.7	JA	2/3V280	1.0	JA	3/3V310	1.6	SH	4/3V330	2.1	SH
1/3V300	0.8	JA	2/3V300	1.1	JA	3/3V330	1.8	SH	4/3V360	2.3	SH
1/3V310	0.9	JA	2/3V310	1.2	JA	3/3V360	2.0	SH	4/3V410	2.8	SH
1/3V330	1.1	JA	2/3V330	1.2	SH	3/3V410	2.7	SH	4/3V450	3.1	SDS
1/3V360	1.3	SH	2/3V360	1.7	SH	3/3V450	3.6	SDS	4/3V470	3.7	SDS
1/3V410	1.8	SH	2/3V410	2.3	SH	3/3V470	3.6	SDS	4/3V500	4.3	SDS
1/3V450	3.1	SH	2/3V450	3.5	SH	3/3V500	3.9	SDS	4/3V530	5.0	SDS
1/3V470	2.1	SH	2/3V470	2.6	SH	3/3V530	4.0	SDS	4/3V560	5.5	SDS
1/3V500	2.3	SH	2/3V500	2.9	SH	3/3V560	4.4	SDS	4/3V600	7.0	SK
1/3V530	2.8	SH	2/3V530	3.1	SH	3/3V600	4.9	SDS	4/3V650	7.3	SK
1/3V560	3.0	SH	2/3V560	3.4	SH	3/3V650	5.8	SDS	4/3V690	8.2	SK
1/3V600	3.4	SH	2/3V600	3.8	SH	3/3V690	5.9	SDS	4/3V800	9.4	SK
1/3V650	3.7	SH	2/3V650	4.5	SDS	3/3V800	8.2	SK	4/3V1060	13.4	SK
1/3V690	4.1	SH	2/3V690	4.7	SDS	3/3V1060	12.0	SK	4/3V1400	18.3	SK
1/3V800	4.8	SDS	2/3V800	6.0	SDS	3/3V1400	14.8	SK	4/3V1900	29.7	SF
1/3V1060	7.4	SDS	2/3V1060	9.6	SK	3/3V1900	26.0	SF	4/3V2500	44.0	SF
1/3V1400	12.1	SK	2/3V1400	12.6	SK	3/3V2500	42.0	SF	4/3V3350	78.0	E
1/3V1900	18.0	SK	2/3V1900	20.6	SK	3/3V3350	78.0	SF			
			2/3V2500	31.5	SF						

5 GROOVE			6 GROOVE			8 GROOVE			10 GROOVE		
PART NUMBER	WEIGHT (LBS)	BUSHING	PART NUMBER	WEIGHT (LBS)	BUSHING	PART NUMBER	WEIGHT (LBS)	BUSHING	PART NUMBER	WEIGHT (LBS)	BUSHING
5/3V470	4.3	SDS	6/3V470	5.0	SK	8/3V470	5.8	SK	10/3V470	5.8	SK
5/3V500	4.8	SDS	6/3V500	5.7	SK	8/3V500	6.8	SK	10/3V500	6.8	SK
5/3V530	5.9	SK	6/3V530	6.7	SK	8/3V530	7.6	SK	10/3V530	7.6	SK
5/3V560	6.8	SK	6/3V560	7.5	SK	8/3V560	8.7	SK	10/3V560	8.7	SK
5/3V600	8.0	SK	6/3V600	8.8	SK	8/3V600	10.3	SK	10/3V600	10.3	SK
5/3V650	8.1	SK	6/3V650	9.3	SK	8/3V650	10.7	SK	10/3V650	10.7	SK
5/3V690	9.2	SK	6/3V690	10.0	SK	8/3V690	11.8	SK	10/3V690	11.8	SK
5/3V800	10.8	SK	6/3V800	11.7	SK	8/3V800	15.5	SF	10/3V800	15.5	SF
5/3V1060	15.3	SK	6/3V1060	19.1	SF	8/3V1060	21.9	SF	10/3V1060	21.9	SF
5/3V1400	23.4	SF	6/3V1400	24.2	SF	8/3V1400	33.4	E	10/3V1400	33.4	E
5/3V1900	37.6	SF	6/3V1900	24.2	E	8/3V1900	47.2	E	10/3V1900	47.2	E
5/3V2500	53.0	E	6/3V2500	65.7	E	8/3V2500	67.8	E	10/3V2500	67.8	F
5/3V3350	87.0	E	6/3V3350	80.0	E	8/3V3350	112.0	F	10/3V3350	112.0	F

**EXAMPLE SIZING:**

Part Number: 1/3V450SH

1 = Number of Grooves 3V = Belt Section Size

4.50 = Outside Sheave Diameter (IN)

SH = Bushing Size & Type

Part Number: 2/3V560SH

2 = Number of Grooves 3V = Belt Section Size

5.60 = Outside Sheave Diameter (IN)

SH = Bushing Size & Type

Part Number: 4/3V2500SF

4 = Number of Grooves 3V = Belt Section Size

25.00 = Outside Sheave Diameter (IN)

SF = Bushing Size & Type



**5V SECTION SHEAVES**

2 GROOVE			3 GROOVE			4 GROOVE			5 GROOVE		
PART NUMBER	WEIGHT (LBS)	BUSHING	PART NUMBER	WEIGHT (LBS)	BUSHING	PART NUMBER	WEIGHT (LBS)	BUSHING	PART NUMBER	WEIGHT (LBS)	BUSHING
2/5V440	3.3	SH	3/5V440	4.2	SDS	4/5V440	5.4	SD	5/5V440	6.4	SD
2/5V465	3.7	SDS	3/5V465	4.7	SDS	4/5V465	6.3	SD	5/5V465	7.2	SD
2/5V490	3.9	SDS	3/5V490	4.8	SDS	4/5V490	6.8	SD	5/5V490	7.8	SD
2/5V520	4.6	SDS	3/5V520	5.9	SDS	4/5V520	7.7	SD	5/5V520	9.0	SD
2/5V550	5.1	SDS	3/5V550	6.6	SDS	4/5V550	8.9	SD	5/5V550	10.2	SD
2/5V590	5.6	SDS	3/5V590	7.5	SD	4/5V590	10.2	SD	5/5V590	10.8	SK
2/5V630	7.4	SK	3/5V630	9.3	SK	4/5V630	10.8	SK	5/5V630	12.3	SK
2/5V670	7.5	SK	3/5V670	10.8	SK	4/5V670	12.4	SK	5/5V670	13.4	SF
2/5V710	7.9	SK	3/5V710	11.4	SF	4/5V710	13.4	SF	5/5V710	15.2	SF
2/5V750	8.7	SK	3/5V750	12.5	SF	4/5V750	15.1	SF	5/5V750	16.9	SF
2/5V800	12.7	SF	3/5V800	10.0	SK	4/5V800	18.0	E	5/5V800	19.7	E
2/5V850	10.8	SK	3/5V850	14.5	SF	4/5V850	20.1	E	5/5V850	23.1	E
2/5V900	11.4	SK	3/5V900	15.6	F	4/5V900	22.3	E	5/5V900	26.4	E
2/5V925	12.0	SK	3/5V925	15.9	SF	4/5V925	23.9	E	5/5V925	28.3	E
2/5V975	12.6	SK	3/5V975	17.0	SF	4/5V975	23.3	E	5/5V975	26.2	E
2/5V1030	14.5	SK	3/5V1030	18.2	SF	4/5V1030	25.5	E	5/5V1030	28.5	E
2/5V1090	15.5	SK	3/5V1090	19.4	SF	4/5V1090	28.0	E	5/5V1090	30.7	E
2/5V1130	14.3	SK	3/5V1130	20.0	F	4/5V1130	28.5	E	5/5V1130	32.3	E
2/5V1180	17.1	SK	3/5V1180	21.2	SF	4/5V1180	29.9	E	5/5V1180	33.5	E
2/5V1250	18.8	SF	3/5V1250	28.3	E	4/5V1250	31.2	E	5/5V1250	36.3	E
2/5V1320	19.8	SF	3/5V1320	29.9	E	4/5V1320	33.7	E	5/5V1320	38.4	E
2/5V1400	22.3	SF	3/5V1400	31.1	E	4/5V1400	34.4	E	5/5V1400	40.0	E
2/5V1500	23.9	SF	3/5V1500	32.5	E	4/5V1500	37.0	E	5/5V1500	42.7	E
2/5V1600	26.0	SF	3/5V1600	35.6	E	4/5V1600	39.6	E	5/5V1600	58.0	E
2/5V1870	32.6	SF	3/5V1870	42.8	E	4/5V1870	51.8	E	5/5V1870	67.0	F
2/5V2120	38.0	SF	3/5V2120	49.4	E	4/5V2120	58.4	E	5/5V2120	88.0	F
2/5V2360	46.0	E	3/5V2360	56.4	E	4/5V2360	70.0	F	5/5V2360	114.9	F
2/5V2800	71.1	E	3/5V2800	70.0	E	4/5V2800	92.0	F	5/5V2800	126.0	F
			3/5V3150	95	F	4/5V3150	108.0	F	5/5V3150	132.0	J
			3/5V3750	151.5	F	4/5V3750	138.0	F	5/5V3750	174.0	J
			3/5V5000	185	F	4/5V5000	227.0	J	5/5V5000	247.0	J

**KS SHEAVES**  
SHEAVES & BUSHINGS



**ADDITIONAL SIZES AVAILABLE.  
CONTACT AN OPTIBELT  
REPRESENTATIVE FOR MORE  
INFORMATION**



<p><b>EXAMPLE SIZING:</b> Part Number: 2/5V590SDS 2 = Number of Grooves 5V = Belt Section Size 5.90 = Outside Sheave Diameter (IN) SDS = Bushing Size &amp; Type</p>	<p>Part Number: 3/5V550SDS 3 = Number of Grooves 5V = Belt Section Size 5.50 = Outside Sheave Diameter (MM) SDS = Bushing Size &amp; Type</p>	<p>Part Number: 5/5V2800F 5 = Number of Grooves 5V = Belt Section Size 28.00 = Outside Sheave Diameter (IN) E = Bushing Size &amp; Type</p>
--------------------------------------------------------------------------------------------------------------------------------------------------------------------------------------	-----------------------------------------------------------------------------------------------------------------------------------------------------------	---------------------------------------------------------------------------------------------------------------------------------------------------------



**5V SECTION SHEAVES**

6 GROOVE		
PART NUMBER	WEIGHT (LBS)	BUSHING
6/5V440	7.7	SD
6/5V465	8.1	SD
6/5V490	8.1	SD
6/5V520	10.5	SD
6/5V550	12.0	SD
6/5V590	12.6	SK
6/5V630	14.5	SK
6/5V670	15.4	SF
6/5V710	17.4	SF
6/5V750	19.4	SF
6/5V800	22.7	E
6/5V850	26.0	E
6/5V900	29.4	E
6/5V925	30.8	E
6/5V975	35.0	E
6/5V1030	33.0	E
6/5V1090	35.6	E
6/5V1130	36.7	E
6/5V1180	41.4	E
6/5V1250	45.2	F
6/5V1320	50.0	F
6/5V1400	52.6	F
6/5V1500	55.2	F
6/5V1600	58.0	F
6/5V1870	70.0	F
6/5V2120	78.0	F
6/5V2360	117.5	J
6/5V2800	125.0	J
6/5V3150	145.0	J
6/5V3750	235.0	J
6/5V5000	330.0	M

8 GROOVE		
PART NUMBER	WEIGHT (LBS)	BUSHING
8/5V710	20.7	SF
8/5V750	23.1	SF
8/5V800	26.8	E
8/5V850	29.5	E
8/5V900	35.0	E
8/5V925	40.5	SF
8/5V975	46.0	F
8/5V1030	47.3	F
8/5V1090	48.5	F
8/5V1130	50.0	F
8/5V1180	53.0	F
8/5V1250	56.3	F
8/5V1320	59.0	F
8/5V1400	63.5	F
8/5V1500	68.0	F
8/5V1600	74.0	F
8/5V1870	94.0	J
8/5V2120	106.0	J
8/5V2360	120.0	J
8/5V2800	145.0	J
8/5V3150	196.2	M
8/5V3750	248.0	M
8/5V5000	367.0	M

10 GROOVE		
PART NUMBER	WEIGHT (LBS)	BUSHING
10/5V800	30.9	E
10/5V850	34.9	E
10/5V900	43.7	F
10/5V925	45.6	F
10/5V975	51.0	F
10/5V1030	59.0	F
10/5V1090	65.5	F
10/5V1130	60.8	F
10/5V1180	63.0	F
10/5V1250	71.3	J
10/5V1320	79.5	J
10/5V1400	88.0	J
10/5V1500	94.5	J
10/5V1600	101.2	J
10/5V1870	109.5	J
10/5V2120	122.0	J
10/5V2360	174.0	M
10/5V2800	214.0	M
10/5V3150	238.0	M
10/5V3750	283.0	M
10/5V5000	427.0	M

**KS SHEAVES**  
SHEAVES & BUSHINGS

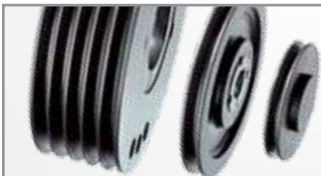

**ADDITIONAL SIZES AVAILABLE.  
CONTACT AN OPTIBELT  
REPRESENTATIVE FOR MORE  
INFORMATION**



**EXAMPLE SIZING:**

Part Number: 6/5V490SD

6 = Number of Grooves 5V = Belt Section Size

4.90 = Outside Sheave Diameter (IN)

SD = Bushing Size & Type

Part Number: 8/5V1030F

8 = Number of Grooves 5V = Belt Section Size

10.30 = Outside Sheave Diameter (IN)

F = Bushing Size & Type

Part Number: 10/5V800E

10 = Number of Grooves 5V = Belt Section Size

8.00 = Outside Sheave Diameter (IN)

E = Bushing Size & Type



**8V SECTION SHEAVES**

4 GROOVE		
PART NUMBER	WEIGHT (LBS)	BUSHING
4/8V1250	60	F
4/8V1320	64	F
4/8V1400	68.3	F
4/8V1500	72.6	F
4/8V1600	77	F
4/8V1700	83.5	F
4/8V1800	90	F
4/8V1900	112	F
4/8V2000	114	J
4/8V2100	140	J
4/8V2240	150	J
4/8V2480	211	M
4/8V3000	264	M
4/8V3550	367	M
4/8V4000	300	M

5 GROOVE		
PART NUMBER	WEIGHT (LBS)	BUSHING
5/8V1250	82.8	F
5/8V1320	96	F
5/8V1400	81	F
5/8V1500	84.5	F
5/8V1600	95.5	F
5/8V1700	104.5	J
5/8V1800	115.2	J
5/8V1900	122	J
5/8V2000	133	J
5/8V2100	140	J
5/8V2240	182	M
5/8V2480	201	M
5/8V3000	254	M
5/8V3550	298	M
5/8V4000	337	M

6 GROOVE		
PART NUMBER	WEIGHT (LBS)	BUSHING
6/8V1250	81	F
6/8V1320	85.4	F
6/8V1400	96	F
6/8V1500	110	J
6/8V1600	118	J
6/8V1700	126	J
6/8V1800	133	J
6/8V1900	157	J
6/8V2000	185	M
6/8V2100	194	M
6/8V2240	221	M
6/8V2480	248	M
6/8V3000	276	M
6/8V3550	444	N
6/8V4000	519	N
6/8V5300	768	N

8 GROOVE		
PART NUMBER	WEIGHT (LBS)	BUSHING
8/8V1250	117	J
8/8V1320	131	J
8/8V1400	127	J
8/8V1500	146	J
8/8V1600	162	J
8/8V1700	228	M
8/8V1800	230	M
8/8V1900	222	M
8/8V2000	213	M
8/8V2100	230	M
8/8V2240	244	M
8/8V2480	365.7	N
8/8V3000	410	N
8/8V3550	508	N
8/8V4000	592	N

10 GROOVE		
PART NUMBER	WEIGHT (LBS)	BUSHING
10/8V1250	134	J
10/8V1320	150.5	J
10/8V1400	167	J
10/8V1500	225	M
10/8V1600	263	M
10/8V1700	267.5	M
10/8V1800	272	M
10/8V1900	269	M
10/8V2000	253	M
10/8V2100	267	M
10/8V2240	332	N
10/8V2480	356	N
10/8V3000	425	N
10/8V5300	1137	P

**KS SHEAVES**  
SHEAVES & BUSHINGS

**ADDITIONAL SIZES AVAILABLE. CONTACT AN OPTIBELT REPRESENTATIVE FOR MORE INFORMATION**

**EXAMPLE SIZING:**

Part Number: 4/8V1500F

4 = Number of Grooves 8V = Belt Section Size

15.00 = Outside Sheave Diameter (IN)

F = Bushing Size & Type

Part Number: 6/8V3000N

6 = Number of Grooves 8V = Belt Section Size

30.00 = Outside Sheave Diameter (MM)

N = Bushing Size & Type

Part Number: 8/8V2000M

8 = Number of Grooves 8V = Belt Section Size

20.00 = Outside Sheave Diameter (IN)

M = Bushing Size & Type



**B SECTION SHEAVES**

1 GROOVE			2 GROOVE			3 GROOVE			4 GROOVE		
PART NUMBER	WEIGHT (LBS)	BUSHING	PART NUMBER	WEIGHT (LBS)	BUSHING	PART NUMBER	WEIGHT (LBS)	BUSHING	PART NUMBER	WEIGHT (LBS)	BUSHING
1/B34	1.4	SH	2/B34	2.4	SH	3/B34	3.3	SH	4/B34	4.3	SD
1/B36	1.6	SH	2/B36	2.7	SH	3/B36	3.6	SH	4/B36	4.8	SD
1/B38	1.7	SH	2/B38	2.9	SH	3/B38	3.8	SH	4/B38	5.2	SD
1/B40	1.9	SH	2/B40	3.2	SH	3/B40	4.2	SH	4/B40	5.6	SD
1/B42	2.2	SH	2/B42	3.7	SH	3/B42	4.8	SH	4/B42	6.2	SD
1/B44	2.5	SH	2/B44	4.1	SH	3/B44	5.3	SH	4/B44	6.6	SD
1/B46	2.5	SDS	2/B46	4.2	SDS	3/B46	6.0	SD	4/B46	7.2	SD
1/B48	2.8	SDS	2/B48	4.6	SDS	3/B48	6.5	SD	4/B48	7.9	SD
1/B50	3.1	SDS	2/B50	5.0	SDS	3/B50	7.2	SD	4/B50	8.4	SD
1/B52	3.3	SDS	2/B52	5.4	SDS	3/B52	7.8	SD	4/B52	9.2	SD
1/B54	3.7	SDS	2/B54	5.8	SDS	3/B54	8.4	SD	4/B54	9.8	SD
1/B56	4.2	SDS	2/B56	6.1	SDS	3/B56	9.0	SD	4/B56	10.7	SD
1/B58	3.9	SDS	2/B58	6.1	SDS	3/B58	9.7	SD	4/B58	11.4	SD
1/B60	4.0	SDS	2/B60	6.4	SDS	3/B60	8.9	SD	4/B60	10.9	SD
1/B62	4.2	SDS	2/B62	6.7	SDS	3/B62	9.4	SD	4/B62	11.3	SD
1/B64	4.3	SDS	2/B64	7.1	SDS	3/B64	9.7	SD	4/B64	11.7	SD
1/B66	5.3	SDS	2/B66	7.8	SDS	3/B66	11.1	SD	4/B66	13.0	SD
1/B70	5.6	SDS	2/B70	9.5	SK	3/B70	11.4	SK	4/B70	13.7	SK
1/B74	6.0	SDS	2/B74	10.2	SK	3/B74	12.5	SK	4/B74	14.8	SK
1/B80	6.6	SDS	2/B80	10.8	SK	3/B80	13.6	SK	4/B80	16.3	SK
1/B86	6.8	SDS	2/B86	11.7	SK	3/B86	14.6	SK	4/B86	17.7	SK
1/B94	7.4	SDS	2/B94	13.2	SK	3/B94	16.6	SK	4/B94	19.7	SK
1/B110	10.5	SDS	2/B110	16.4	SK	3/B110	20.8	SK	4/B110	25.2	SK
1/B124	11.5	SDS	2/B124	18.3	SK	3/B124	22.5	SK	4/B124	28.4	SK
1/B136	12.9	SDS	2/B136	20.3	SK	3/B136	25.3	SK	4/B136	31.3	SK
1/B154	17.1	SK	2/B154	23.8	SK	3/B154	29.8	SK	4/B154	37.6	SF
1/B160	18.6	SK	2/B160	24.3	SK	3/B160	30.3	SK	4/B160	38.6	SF
1/B184	23.8	SK	2/B184	31.8	SK	3/B184	39.1	SK	4/B184	45.2	SK
1/B200	27.0	SK	2/B200	33.4	SF	3/B200	43.0	SF	4/B200	52.0	SF
1/B250	39.0	SF	2/B250	45.0	SF	3/B250	56.0	SF	4/B250	72.0	E
1/B300	57.0	SF	2/B300	71.2	SF	3/B300	77.0	SF	4/B300	97.0	E
			2/B380	103.0	F	3/B380	115.0	E	4/B380	151.1	E

**KS SHEAVES**  
SHEAVES & BUSHINGS



**ADDITIONAL SIZES AVAILABLE.  
CONTACT AN OPTIBELT  
REPRESENTATIVE FOR MORE  
INFORMATION**



<p><b>EXAMPLE SIZING:</b> Part Number: 1/B40SH 1 = Number of Grooves B = Belt Section Size 4.0 = Pitch Diameter (IN) SH = Bushing Size &amp; Type</p>	<p>Part Number: 2/B58SDS 2 = Number of Grooves B = Belt Section Size 5.8 = Pitch Diameter (IN) SDS = Bushing Size &amp; Type</p>	<p>Part Number: 4/B86SK 4 = Number of Grooves B = Belt Section Size 8.6 = Pitch Diameter (IN) SK = Bushing Size &amp; Type</p>
-----------------------------------------------------------------------------------------------------------------------------------------------------------------------	----------------------------------------------------------------------------------------------------------------------------------------------	--------------------------------------------------------------------------------------------------------------------------------------------



**B SECTION SHEAVES**

5 GROOVE			6 GROOVE			8 GROOVE			10 GROOVE		
PART NUMBER	WEIGHT (LBS)	BUSHING	PART NUMBER	WEIGHT (LBS)	BUSHING	PART NUMBER	WEIGHT (LBS)	BUSHING	PART NUMBER	WEIGHT (LBS)	BUSHING
5/B34	5.2	SD	6/B34	5.8	SD	8/B54	15.5	SK	10/B54	18.5	SK
5/B36	5.7	SD	6/B36	6.8	SD	8/B56	16.6	SK	10/B56	19.8	SK
5/B38	6.2	SD	6/B38	7.1	SD	8/B58	17.1	SK	10/B58	21.2	SK
5/B40	6.5	SD	6/B40	7.7	SD	8/B60	18.7	SK	10/B60	22.3	SK
5/B42	7.1	SD	6/B42	8.6	SD	8/B62	19.3	SF	10/B62	22.8	SF
5/B44	7.8	SD	6/B44	9.3	SD	8/B64	20.3	SF	10/B64	24.2	SF
5/B46	8.5	SD	6/B46	9.8	SD	8/B66	22.9	SF	10/B66	26.8	SF
5/B48	9.2	SD	6/B48	10.8	SD	8/B70	24.7	SF	10/B70	28.3	SF
5/B50	9.9	SD	6/B50	11.7	SD	8/B74	26.5	SF	10/B74	31.4	SF
5/B52	10.9	SD	6/B52	12.0	SD	8/B86	35.3	E	10/B86	41.0	E
5/B54	10.5	SK	6/B54	12.5	SK	8/B94	41.9	E	10/B94	47.8	E
5/B56	11.4	SK	6/B56	13.3	SK	8/B110	44.9	E	10/B110	58.0	E
5/B58	12.3	SK	6/B58	14.1	SK	8/B124	52.0	E	10/B124	65.0	E
5/B60	12.8	SK	6/B60	15.4	SK	8/B136	55.0	E	10/B136	80.0	F
5/B62	13.6	SK	6/B62	16.4	SK	8/B154	61.0	E	10/B154	87.0	F
5/B64	14.6	SK	6/B64	17.3	SK	8/B160	64.0	E	10/B160	89.0	F
5/B66	16.7	SK	6/B66	19.3	SK	8/B184	82.0	F	10/B184	102.0	F
5/B70	17.1	SF	6/B70	19.8	SF	8/B200	93.0	F	10/B200	112.0	F
5/B74	18.7	SF	6/B74	22.4	SF	8/B250	116.0	F	10/B250	148.0	F
5/B80	19.3	SF	6/B80	25.4	SF	8/B300	157.0	F	10/B300	188.0	F
5/B86	21.6	SF	6/B86	25.7	SF	8/B380	216.0	F	10/B380	291.0	J
5/B94	24.0	SF	6/B94	27.9	SF						
5/B110	28.7	SF	6/B110	33.5	SF						
5/B124	33.8	SF	6/B124	37.5	SF						
5/B136	37.0	SF	6/B136	42.0	SF						
5/B154	43.0	SF	6/B154	48.9	SF						
5/B160	48.0	SF	6/B160	48.8	SF						
5/B184	51.8	SK	6/B184	60.0	SK						
5/B200	62.0	E	6/B200	72.0	E						
5/B250	85.0	E	6/B250	94.0	E						
5/B300	85.0	E	6/B300	131.0	E						
5/B380	159.0	E	6/B380	183.0	E						

**KS SHEAVES**  
SHEAVES & BUSHINGS

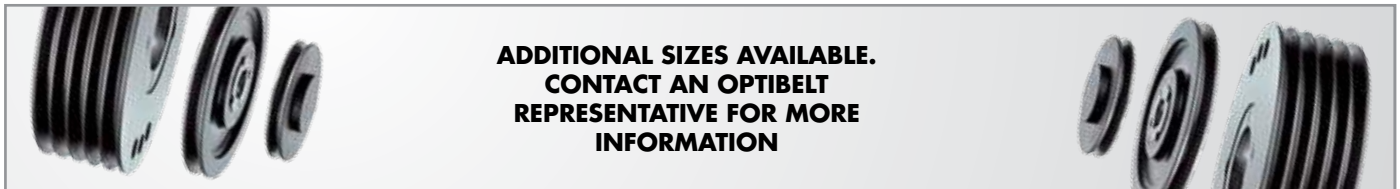

**ADDITIONAL SIZES AVAILABLE.  
CONTACT AN OPTIBELT  
REPRESENTATIVE FOR MORE  
INFORMATION**

**EXAMPLE SIZING:**

Part Number: 5/B50SD

5 = Number of Grooves B Belt Section Size

5.0 = Outside Pitch Diameter (IN)

SD = Bushing Size & Type

Part Number: 6/B136SF

6 = Number of Grooves B Belt Section Size

13.6 = Pitch Diameter (IN)

SF = Bushing Size & Type

Part Number: 8/B300F

8 = Number of Grooves B Belt Section Size

20.0 = Pitch Diameter (IN)

F = Bushing Size & Type



**C SECTION SHEAVES**

1 GROOVE			2 GROOVE			3 GROOVE			4 GROOVE		
PART NUMBER	WEIGHT (LBS)	BUSHING	PART NUMBER	WEIGHT (LBS)	BUSHING	PART NUMBER	WEIGHT (LBS)	BUSHING	PART NUMBER	WEIGHT (LBS)	BUSHING
1/C60	6.8	SK	2/C60	11.4	SF	3/C50	8.4	SD	4/C54	10.2	SD
1/C70	9.7	SF	2/C70	12.4	SF	3/C54	10.2	SD	4/C55	11.8	SD
1/C75	11.4	SF	2/C75	14.4	SF	3/C55	11.1	SD	4/C56	12.4	SD
1/C80	13	SF	2/C80	16.3	SF	3/C56	11.4	SD	4/C60	12.4	SD
1/C90	12.8	SF	2/C90	17.3	SF	3/C60	10.1	SF	4/C70	10.9	SF
1/C95	13.3	SF	2/C95	18.1	SF	3/C70	15.9	SF	4/C75	18	SF
1/C100	14.2	SF	2/C100	19.4	SF	3/C75	18	SF	4/C80	20.5	SF
1/C105	15.2	SF	2/C105	20.6	SF	3/C80	20.9	E	4/C90	24	E
1/C110	16.2	SF	2/C110	22	SF	3/C90	27.1	E	4/C95	30.7	E
1/C120	18.6	SF	2/C120	24.2	SF	3/C95	29.1	E	4/C100	34.9	E
1/C130	19.1	SF	2/C130	27.8	SF	3/C100	30.1	E	4/C105	38.1	E
1/C140	20.3	SF	2/C140	30.1	SF	3/C105	30.8	E	4/C110	35.9	E
1/C150	22	SF	2/C150	32	SF	3/C110	32.9	E	4/C120	38.4	E
1/C180	23.5	SF	2/C180	34.9	SF	3/C120	38.4	E	4/C130	43.6	E
1/C200	31.8	SF	2/C200	42.1	SF	3/C130	42.4	E	4/C140	49.4	E
1/C240	41.2	SF	2/C240	57.6	SF	3/C140	41.7	E	4/C150	50.7	E
			2/C270	79.4	F	3/C150	45	E	4/C180	52	E
			2/C300	82.4	F	3/C180	49.8	E	4/C200	60.2	E
						3/C200	62.6	E	4/C240	76.9	E
						3/C240	78.7	E	4/C270	100.4	F
						3/C270	103	F	4/C300	116.8	F
						3/C300	115.4	F	4/C360	136.1	F
						3/C360	161.7	F	4/C440	194.2	F
						3/C440	242.8	F	4/C500	270.4	J
						3/C500	190	F	4/C500	337.4	J

**KS SHEAVES**  
SHEAVES & BUSHINGS

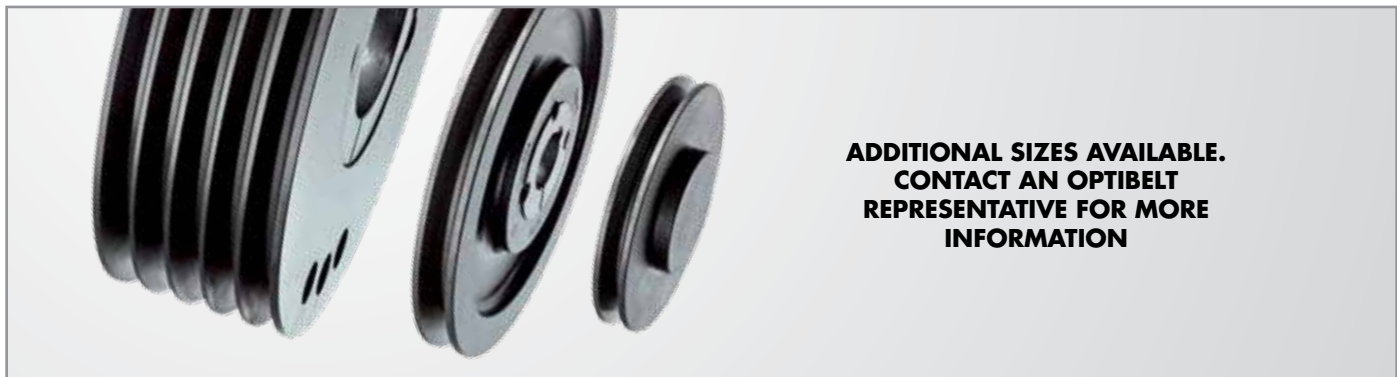

**ADDITIONAL SIZES AVAILABLE.  
CONTACT AN OPTIBELT  
REPRESENTATIVE FOR MORE  
INFORMATION**

**EXAMPLE SIZING:**

Part Number: 1/C70SF

1 = Number of Grooves C = Belt Section Size

70 = Pitch Diameter (IN)

SF = Bushing Size & Type

Part Number: 2/C105SF

2 = Number of Grooves C = Belt Section Size

105 = Pitch Diameter (IN)

SF = Bushing Size & Type

Part Number: 4/C180E

4 = Number of Grooves C = Belt Section Size

180 = Pitch Diameter (IN)

E = Bushing Size & Type





**C SECTION SHEAVES**

5 GROOVE			6 GROOVE			8 GROOVE			10 GROOVE		
PART NUMBER	WEIGHT (LBS)	BUSHING	PART NUMBER	WEIGHT (LBS)	BUSHING	PART NUMBER	WEIGHT (LBS)	BUSHING	PART NUMBER	WEIGHT (LBS)	BUSHING
5/C60	12.5	SF	6/C60	14	SF	8/C70	29.2	SF	10/C80	43.9	E
5/C70	20.8	SF	6/C70	23.6	SF	8/C80	37.3	E	10/C90	59.6	J
5/C75	23.6	SF	6/C75	26.6	SF	8/C90	50.5	F	10/C95	67.8	J
5/C80	27.3	E	6/C80	30.6	E	8/C95	57.6	F	10/C100	74.1	J
5/C90	34.5	E	6/C90	43	F	8/C100	62.6	F	10/C105	82.2	J
5/C95	39.1	E	6/C95	49.1	F	8/C105	69	F	10/C110	90.6	J
5/C100	42.4	E	6/C100	54	F	8/C110	75.6	F	10/C120	108.4	J
5/C105	40.4	E	6/C105	60	F	8/C120	72.9	F	10/C130	136	J
5/C110	43.1	E	6/C110	66.2	F	8/C130	81.3	F	10/C140	110.8	J
5/C120	48.8	E	6/C120	62.5	F	8/C140	88	F	10/C180	141.3	J
5/C130	55.1	E	6/C130	70	F	8/C150	105	F	10/C200	169.7	J
5/C140	57.2	E	6/C140	73	F	8/C180	108.6	F	10/C240	263.1	M
5/C150	68.2	E	6/C150	75	F	8/C200	146.5	J	10/C300	332.1	M
5/C180	71.2	E	6/C180	87.7	F	8/C240	173.4	J	10/C360	397.5	M
5/C200	96.5	F	6/C200	109.8	F	8/C270	226.3	J	10/C440	531.8	M
5/C240	106.7	F	6/C240	122.1	F	8/C300	240	J	10/C500	600	M
5/C270	129.2	F	6/C270	158.8	J	8/C360	355.3	M			
5/C300	160.8	F	6/C300	192.8	J	8/C440	452	M			
5/C360	220.3	J	6/C360	254.5	J	8/C500	541.1	M			
5/C440	293.2	J	6/C440	315	J						
5/C500	275	J	6/C500	325	M						

KS SHEAVES  
SHEAVES & BUSHINGS

**ADDITIONAL SIZES AVAILABLE.  
CONTACT AN OPTIBELT  
REPRESENTATIVE FOR MORE  
INFORMATION**



**EXAMPLE SIZING:**

Part Number: 6/C200F  
6 = Number of Grooves C = Belt Section Size  
20.0 = Pitch Diameter (IN)  
F = Bushing Size & Type

Part Number: 8/C150F  
8 = Number of Grooves C = Belt Section Size  
15.0 = Pitch Diameter (IN)  
F = Bushing Size & Type

Part Number: 10/C360M  
10 = Number of Grooves C = Belt Section Size  
36.0 = Pitch Diameter (IN)  
M = Bushing Size & Type



**optibelt KS**  
H BUSHING SHEAVES

**A & 2A SECTIONS**

**KS H A/2A**  
SHEAVES & BUSHINGS

A SECTIONS			
PART NUMBER	OUTSIDE DIAMETER (IN.)	4L & A PITCH DIAMETER (IN.)	5L & B PITCH DIAMETER (IN.)
AK30H	3.05	2.46	2.8
AK32H	3.25	2.66	3.0
AK34H	3.45	2.86	3.2
AK39H	3.75	3.16	3.5
AK41H	3.95	3.36	3.7
AK44H	4.25	3.66	4.0
AK46H	4.45	3.86	4.2
AK49H	4.75	4.16	4.5
AK51H	4.95	4.36	4.7
AK54H	5.25	4.66	5.0
AK56H	5.45	4.86	5.2
AK59H	5.75	5.16	5.5
AK61H	5.95	5.36	5.7
AK64H	6.25	5.66	6.0
AK66H	6.45	5.86	6.2
AK69H	6.75	6.16	6.5
AK71H	6.95	6.36	6.7
AK74H	7.25	6.66	7.0
AK79H	7.75	7.16	7.5
AK84H	8.25	7.66	8.0
AK89H	8.75	8.16	8.5
AK94H	9.25	8.66	9.0
AK99H	9.75	9.16	9.5
AK104H	10.25	9.66	10.0
AK109H	10.75	10.16	10.5
AK114H	11.25	10.66	11.0
AK124H	12.25	11.66	12.0
AK134H	13.25	12.66	13.0
AK144H	14.25	13.66	14.0
AK154H	15.25	14.66	15.0
AK184H	18.25	17.66	18.0

2A SECTIONS (2 GROOVE)			
PART NUMBER	OUTSIDE DIAMETER (IN.)	4L & A PITCH DIAMETER (IN.)	5L & B PITCH DIAMETER (IN.)
2AK30H	3.05	2.46	2.8
2AK32H	3.25	2.66	3.0
2AK34H	3.45	2.86	3.2
2AK39H	3.75	3.16	3.5
2AK41H	3.95	3.36	3.7
2AK44H	4.25	3.66	4.0
2AK46H	4.45	3.86	4.2
2AK49H	4.75	4.16	4.5
2AK51H	4.95	4.36	4.7
2AK54H	5.25	4.66	5.0
2AK56H	5.45	4.86	5.2
2AK59H	5.75	5.16	5.5
2AK61H	5.95	5.36	5.7
2AK64H	6.25	5.66	6.0
2AK74H	7.25	6.66	7.0
2AK84H	8.25	7.66	8.0
2AK94H	9.25	8.66	9.0
2AK104H	10.25	9.66	10.0
2AK114H	11.25	10.66	11.0
2AK124H	12.25	11.66	12.0
2AK134H	13.25	12.66	13.0
2AK144H	14.25	13.66	14.0
2AK154H	15.25	14.66	15.0
2AK184H	18.25	17.66	18.0



**ADDITIONAL SIZES AVAILABLE.  
CONTACT AN OPTIBELT  
REPRESENTATIVE FOR MORE  
INFORMATION**

# B & 2B SECTIONS

# optibelt KS H BUSHING SHEAVES



B SECTIONS			
PART NUMBER	OUTSIDE DIAMETER (IN.)	4L & A PITCH DIAMETER (IN.)	5L & B PITCH DIAMETER (IN.)
BK30H	3.15	2.4	2.8
BK32H	3.35	2.6	3.0
BK34H	3.55	2.8	3.2
BK36H	3.75	3.0	3.4
BK40H	3.95	3.2	3.6
BK45H	4.25	3.5	3.9
BK47H	4.45	3.7	4.1
BK50H	4.75	4.0	4.4
BK52H	4.95	4.2	4.6
BK55H	5.25	4.5	4.9
BK57H	5.45	4.7	5.1
BK60H	5.75	5.0	5.4
BK62H	5.95	5.2	5.6
BK65H	6.25	5.5	5.9
BK67H	6.45	5.7	6.1
BK70H	6.75	6.0	6.4
BK72H	6.95	6.2	6.6
BK75H	7.25	6.5	6.9
BK77H	7.45	6.7	7.1
BK80H	7.75	7.0	7.4
BK85H	8.25	7.5	7.9
BK90H	8.75	8.0	8.4
BK95H	9.25	8.5	8.9
BK100H	9.75	9.0	9.4
BK105H	10.25	9.5	9.9
BK110H	10.75	10.0	10.4
BK115H	11.25	10.5	10.9
BK120H	11.75	11.0	11.4
BK130H	12.75	12.0	12.4
BK140H	13.75	13.0	13.4
BK150H	14.75	14.0	14.4
BK160H	15.75	15.0	15.4
BK190H	18.75	18.0	18.4

2B SECTIONS (2 GROOVE)			
PART NUMBER	OUTSIDE DIAMETER (IN.)	4L & A PITCH DIAMETER (IN.)	5L & B PITCH DIAMETER (IN.)
2BK32H	3.35	2.6	3.0
2BK34H	3.55	2.8	3.2
2BK36H	3.75	3.0	3.4
2BK40H	3.95	3.2	3.6
2BK45H	4.25	3.5	3.9
2BK47H	4.45	3.7	4.1
2BK50H	4.75	4.0	4.4
2BK52H	4.95	4.2	4.6
2BK55H	5.25	4.5	4.9
2BK57H	5.45	4.7	5.1
2BK60H	5.75	5.0	5.4
2BK62H	5.95	5.2	5.6
2BK65H	6.25	5.5	5.9
2BK67H	6.45	5.7	6.1
2BK70H	6.75	6.0	6.4
2BK80H	7.75	7.0	7.4
2BK90H	8.75	8.0	8.4
2BK100H	9.75	9.0	9.4
2BK110H	10.75	10.0	10.4
2BK120H	11.75	11.0	11.4
2BK130H	12.75	12.0	12.4
2BK140H	13.75	13.0	13.4
2BK160H	15.75	15.0	15.4
2BK190H	18.75	18.0	18.4

KS H B/2B  
SHEAVES & BUSHINGS

**ADDITIONAL SIZES AVAILABLE.  
CONTACT AN OPTIBELT  
REPRESENTATIVE FOR MORE  
INFORMATION**





**optibelt KS**  
BUSHING SHEAVES

**2B SECTIONS**  
BORE TO SIZE

**KS 2B**  
SHEAVES & BUSHINGS

2B SECTIONS (2 GROOVE)			
PART NUMBER	OUTSIDE DIAMETER (IN.)	4L & A PITCH DIAMETER (IN.)	5L & B PITCH DIAMETER (IN.)
2BK25-1/2	2.5	1.9	2.3
2BK25-5/8	2.5	1.9	2.3
2BK25-3/4	2.5	1.9	2.3
2BK25-7/8	2.5	1.9	2.3
2BK27-1/2	2.7	2.1	2.5
2BK27-5/8	2.7	2.1	2.5
2BK27-3/4	2.7	2.1	2.5
2BK27-7/8	2.7	2.1	2.5
2BK27-1	2.7	2.1	2.5
2BK27-1-1/8	2.7	2.1	2.5
2BK28-1/2	2.95	2.2	2.6
2BK28-5/8	2.95	2.2	2.6
2BK28-3/4	2.95	2.2	2.6
2BK28-7/8	2.95	2.2	2.6
2BK28-1	2.95	2.2	2.6
2BK28-1-1/8	2.95	2.2	2.6
2BK30-1/2	3.15	2.4	2.8
2BK30-5/8	3.15	2.4	2.8
2BK30-3/4	3.15	2.4	2.8
2BK30-7/8	3.15	2.4	2.8
2BK30-1	3.15	2.4	2.8
2BK30-1-1/8	3.15	2.4	2.8
2BK30-1-3/8	3.15	2.4	2.8
2BK32-1/2	3.35	2.6	3.0
2BK32-5/8	3.35	2.6	3.0
2BK32-3/4	3.35	2.6	3.0
2BK32-7/8	3.35	2.6	3.0
2BK32-1	3.35	2.6	3.0
2BK32-1-1/8	3.35	2.6	3.0
2BK34-5/8	3.55	2.8	3.2
2BK34-3/4	3.55	2.8	3.2
2BK34-7/8	3.55	2.8	3.2
2BK34-1	3.55	2.8	3.2
2BK34-1-1/8	3.55	2.8	3.2
2BK36-5/8	3.75	3.0	3.4
2BK36-3/4	3.75	3.0	3.4
2BK36-7/8	3.75	3.0	3.4
2BK36-1	3.75	3.0	3.4
2BK36-1-1/8	3.75	3.0	3.4
2BK36-1-3/8	3.75	3.0	3.4

2B SECTIONS (2 GROOVE)			
PART NUMBER	OUTSIDE DIAMETER (IN.)	4L & A PITCH DIAMETER (IN.)	5L & B PITCH DIAMETER (IN.)
2BK40-5/8	3.95	3.2	3.6
2BK40-3/4	3.95	3.2	3.6
2BK40-7/8	3.95	3.2	3.6
2BK40-1	3.95	3.2	3.6
2BK40-1-1/8	3.95	3.2	3.6
2BK45-1	4.25	3.5	3.9
2BK45-1-1/8	4.25	3.5	3.9
2BK45-1-3/8	4.25	3.5	3.9
2BK47-7/8	4.75	3.7	4.1
2BK47-1	4.75	3.7	4.1
2BK47-1-1/8	4.75	3.7	4.1
2BK47-1-3/8	4.75	3.7	4.1
2BK50-3/4	4.75	4.0	4.4
2BK50-1	4.75	4.0	4.4
2BK50-1-1/8	4.75	4.0	4.4
2BK50-1-3/8	4.75	4.0	4.4
2BK52-5/8	4.95	4.2	4.6
2BK52-7/8	4.95	4.2	4.6
2BK52-1	4.95	4.2	4.6
2BK52-1-1/8	4.95	4.2	4.6
2BK52-1-3/8	4.95	4.2	4.6
2BK55-1-1/8	5.25	4.5	4.9
2BK55-1-3/8	5.25	4.5	4.9
2BK57-1	5.45	4.7	5.1
2BK57-1-1/8	5.45	4.7	5.1
2BK57-1-3/8	5.45	4.7	5.1
2BK60-3/4	5.75	5.0	5.4
2BK60-7/8	5.75	5.0	5.4
2BK60-1	5.75	5.0	5.4
2BK60-1-1/8	5.75	5.0	5.4
2BK60-1-3/8	5.75	5.0	5.4
2BK62-1	5.95	5.2	5.6
2BK62-1-1/8	5.95	5.2	5.6
2BK65-1	6.25	5.5	5.9
2BK65-1-1/8	6.25	5.5	5.9
2BK65-1-3/8	6.25	5.5	5.9
2BK67-1	6.45	5.7	6.1
2BK67-1-1/8	6.45	5.7	6.1
2BK67-1-3/8	6.45	5.7	6.1



**ADDITIONAL SIZES AVAILABLE.  
CONTACT AN OPTIBELT  
REPRESENTATIVE FOR MORE  
INFORMATION**



## 2B SECTIONS

BORE TO SIZE

**optibelt KS**  
BUSHINGS SHEAVES



2B SECTIONS (2 GROOVE)			
PART NUMBER	OUTSIDE DIAMETER (IN.)	4L & A PITCH DIAMETER (IN.)	5L & B PITCH DIAMETER (IN.)
2BK70-3/4	6.75	6.0	6.4
2BK70-1	6.75	6.0	6.4
2BK70-1-1/8	6.75	6.0	6.4
2BK70-1-3/8	6.75	6.0	6.4
2BK70-1-7/16	6.75	6.0	6.4
2BK80-3/4	7.75	7.0	7.4
2BK80-1	7.75	7.0	7.4
2BK80-1-1/8	7.75	7.0	7.4
2BK80-1-3/16	7.75	7.0	7.4
2BK80-1-3/8	7.75	7.0	7.4
2BK80-1-7/16	7.75	7.0	7.4
2BK90-3/4	8.75	8.0	8.4
2BK90-1	8.75	8.0	8.4
2BK90-1-1/8	8.75	8.0	8.4
2BK90-1-3/16	8.75	8.0	8.4
2BK90-1-3/8	8.75	8.0	8.4
2BK90-1-7/16	8.75	8.0	8.4
2B100-3/4	9.75	9.0	9.4
2B100-1	9.75	9.0	9.4
2B100-1-3/16	9.75	9.0	9.4
2B100-1-3/8	9.75	9.0	9.4
2B100-1-7/16	9.75	9.0	9.4
2B110-1	10.75	10.0	10.4
2B110-1-3/16	10.75	10.0	10.4
2B110-1-7/16	10.75	10.0	10.4

2B SECTIONS (2 GROOVE)			
PART NUMBER	OUTSIDE DIAMETER (IN.)	4L & A PITCH DIAMETER (IN.)	5L & B PITCH DIAMETER (IN.)
2B120-1	11.75	11.0	11.4
2B120-1-3/16	11.75	11.0	11.4
2B120-1-7/16	11.75	11.0	11.4
2B130-1	12.75	12.0	12.4
2B130-1-3/16	12.75	12.0	12.4
2B130-1-7/16	12.75	12.0	12.4
2B140-1	13.75	13.0	13.4
2B140-1-3/16	13.75	13.0	13.4
2B140-1-7/16	13.75	13.0	13.4
2B160-1	15.75	15.0	15.4
2B160-1-3/16	15.75	15.0	15.4
2B160-1-7/16	15.75	15.0	15.4
2B190-1-3/16	18.75	18.0	18.4
2B190-1-1/4	18.75	18.0	18.4
2B190-1-7/16	18.75	18.0	18.4

STANDARD KEY DIMENSIONS	
SHAFT DIAMETER	KEYSEAT (WIDTH X DEPTH)
1/2	None
5/8-7/8	3/16 x 3/32
15/16-1 1/4	1/4 x 1/8
1-5/16-1 3/8	5/16 x 5/32
1-7/16-1 3/4	3/8 x 3/16

KS H 2 B  
SHEAVES & BUSHINGS

**ADDITIONAL SIZES AVAILABLE.  
CONTACT AN OPTIBELT  
REPRESENTATIVE FOR MORE  
INFORMATION**





**SPZ/10 SECTIONS**

1 GROOVE		
PART NUMBER	WEIGHT (LBS)	BUSHING
1/SPZ50	0.3	1008
1/SPZ56	0.4	1008
1/SPZ60	0.2	1008
1/SPZ63	0.2	1108
1/SPZ67	0.3	1108
1/SPZ71	0.3	1108
1/SPZ75	0.3	1108
1/SPZ80	0.5	1210
1/SPZ85	0.6	1210
1/SPZ90	0.7	1210
1/SPZ95	0.7	1210
1/SPZ100	0.8	1210
1/SPZ106	0.9	1610
1/SPZ112	1.0	1610
1/SPZ118	0.9	1610
1/SPZ125	1.0	1610
1/SPZ132	1.1	1610
1/SPZ140	1.2	1610
1/SPZ150	1.2	1610
1/SPZ160	1.3	1610
1/SPZ170	1.5	1610
1/SPZ180	1.6	1610
1/SPZ190	1.8	1610
1/SPZ200	2.3	2012
1/SPZ224	2.5	2012
1/SPZ250	2.8	2012
1/SPZ280	2.9	2012
1/SPZ315	3.1	2012
1/SPZ355	3.5	2012
1/SPZ400	6.0	2012
1/SPZ450	6.1	2517

2 GROOVE		
PART NUMBER	WEIGHT (LBS)	BUSHING
2/SPZ50	0.4	1008
2/SPZ56	0.5	1108
2/SPZ60	0.6	1108
2/SPZ63	0.3	1108
2/SPZ67	0.4	1108
2/SPZ71	0.4	1108
2/SPZ75	0.4	1210
2/SPZ80	0.6	1210
2/SPZ85	0.5	1610
2/SPZ90	0.7	1610
2/SPZ95	0.8	1610
2/SPZ100	0.9	1610
2/SPZ106	1.1	1610
2/SPZ112	1.3	1610
2/SPZ118	1.3	1610
2/SPZ125	1.4	1610
2/SPZ132	1.5	1610
2/SPZ140	1.7	1610
2/SPZ150	2.0	2012
2/SPZ160	2.5	2012
2/SPZ170	2.5	2012
2/SPZ180	2.5	2012
2/SPZ190	2.6	2012
2/SPZ200	2.8	2012
2/SPZ224	3.2	2012
2/SPZ250	3.5	2012
2/SPZ280	4.0	2012
2/SPZ315	4.2	2012
2/SPZ355	5.1	2012
2/SPZ400	6.3	2517
2/SPZ450	8.2	2517
2/SPZ500	9.1	2517

3 GROOVE		
PART NUMBER	WEIGHT (LBS)	BUSHING
3/SPZ63	0.4	1108
3/SPZ67	0.5	1108
3/SPZ71	0.6	1108
3/SPZ75	0.6	1210
3/SPZ80	0.7	1210
3/SPZ85	0.6	1610
3/SPZ90	0.8	1610
3/SPZ95	0.9	1610
3/SPZ100	1.1	1610
3/SPZ106	1.3	1610
3/SPZ112	1.3	2012
3/SPZ118	1.6	2012
3/SPZ125	1.8	2012
3/SPZ132	2.3	2012
3/SPZ140	2.6	2012
3/SPZ150	3.1	2012
3/SPZ160	3.6	2012
3/SPZ170	4.2	2012
3/SPZ180	4.8	2012
3/SPZ190	4.9	2012
3/SPZ200	3.5	2012
3/SPZ224	3.9	2012
3/SPZ250	4.3	2012
3/SPZ280	5.3	2517
3/SPZ315	6.1	2517
3/SPZ355	7.3	2517
3/SPZ400	8	2517
3/SPZ450	9.8	2517
3/SPZ500	11.4	2517
3/SPZ630	15.9	2517

**KS SHEAVES SPZ**  
SHEAVES & BUSHINGS



**ADDITIONAL SIZES AVAILABLE.  
CONTACT AN OPTIBELT  
REPRESENTATIVE FOR MORE  
INFORMATION**



**EXAMPLE SIZING:**

Part Number: 1/SPZ132  
1 = Number of Grooves SPZ = Belt Section Size  
132 = Datum Sheave Diameter (MM)

Part Number: 2/SPZ315  
2 = Number of Grooves SPZ = Belt Section Size  
315 = Datum Sheave Diameter (MM)

Part Number: 3/SPZ71  
3 = Number of Grooves SPZ = Belt Section Size  
71 = Datum Sheave Diameter (MM)



**SPZ/10 SECTIONS**

4 GROOVE		
PART NUMBER	WEIGHT (LBS)	BUSHING
4/SPZ80	0.8	1210
4/SPZ85	0.9	1610
4/SPZ90	1.0	1610
4/SPZ95	1.1	1610
4/SPZ100	1.1	1610
4/SPZ106	1.3	1610
4/SPZ112	1.5	2012
4/SPZ118	1.8	2012
4/SPZ125	2.2	2012
4/SPZ132	2.5	2012
4/SPZ140	2.9	2012
4/SPZ150	3.7	2517
4/SPZ160	4.4	2517
4/SPZ170	5.3	2517
4/SPZ180	6.1	2517
4/SPZ190	5.3	2517
4/SPZ200	4.7	2517
4/SPZ224	5.2	2517
4/SPZ250	5.7	2517
4/SPZ280	6.4	2517
4/SPZ315	7.6	2517
4/SPZ355	8.9	2517
4/SPZ400	10.1	2517
4/SPZ450	11.8	3020
4/SPZ500	14.3	3020
4/SPZ630	20.0	3020

5 GROOVE		
PART NUMBER	WEIGHT (LBS)	BUSHING
5/SPZ85	1.0	1610
5/SPZ90	1.2	1610
5/SPZ95	1.3	1610
5/SPZ100	1.3	2012
5/SPZ106	1.5	2012
5/SPZ112	1.8	2012
5/SPZ118	1.8	2012
5/SPZ125	2.3	2012
5/SPZ132	2.7	2517
5/SPZ140	3.2	2517
5/SPZ150	4.0	2517
5/SPZ160	4.8	2517
5/SPZ170	5.9	2517
5/SPZ180	6.3	2517
5/SPZ190	6.3	2517
5/SPZ200	5.5	2517
5/SPZ224	6.0	2517
5/SPZ250	6.4	2517
5/SPZ280	7.1	2517
5/SPZ315	8.6	2517
5/SPZ355	10.0	2517
5/SPZ400	11.7	3020
5/SPZ450	13.9	3020
5/SPZ500	17.6	3020
5/SPZ630	22.7	3020

6 GROOVE		
PART NUMBER	WEIGHT (LBS)	BUSHING
6/SPZ100	1.4	2012
6/SPZ106	1.6	2012
6/SPZ112	1.9	2012
6/SPZ118	2.0	2517
6/SPZ125	2.5	2517
6/SPZ132	2.9	2517
6/SPZ140	3.5	2517
6/SPZ150	4.4	2517
6/SPZ160	5.2	2517
6/SPZ170	6.5	2517
6/SPZ180	6.8	2517
6/SPZ190	6.9	2517
6/SPZ200	6.1	2517
6/SPZ224	6.6	2517
6/SPZ250	7.0	2517
6/SPZ280	7.8	2517
6/SPZ315	9.3	2517
6/SPZ355	10.7	2517
6/SPZ400	14.5	3020
6/SPZ450	16.9	3030
6/SPZ500	19.9	3020
6/SPZ630	33.6	3535

8 GROOVE		
PART NUMBER	WEIGHT (LBS)	BUSHING
8/SPZ140	4.0	2517
8/SPZ150	5.1	2517
8/SPZ160	5.6	2517
8/SPZ180	7.1	3020
8/SPZ200	9.3	3020
8/SPZ224	11.8	3020
8/SPZ250	10.5	3020
8/SPZ280	10.8	3020
8/SPZ355	16.0	3030
8/SPZ400	18.2	3030
8/SPZ450	24.0	3535

**KS SHEAVES SPZ**  
SHEAVES & BUSHINGS

**ADDITIONAL SIZES AVAILABLE. CONTACT AN OPTIBELT REPRESENTATIVE FOR MORE INFORMATION**

**EXAMPLE SIZING:**

Part Number: 4/SPZ150

4 = Number of Grooves SPZ = Belt Section Size  
150 = Datum Sheave Diameter (MM)

Part Number: 5/SPZ280

5 = Number of Grooves SPZ = Belt Section Size  
280 = Datum Sheave Diameter (MM)

Part Number: 6/SPZ106

6 = Number of Grooves SPZ = Belt Section Size  
106 = Datum Sheave Diameter (MM)



**SPA/13 SECTIONS**

1 GROOVE		
PART NUMBER	WEIGHT (LBS)	BUSHING
1/SPA63*	0.6	1008
1/SPA67*	0.3	1008
1/SPA71*	0.4	1108
1/SPA75*	0.2	1108
1/SPA80*	0.5	1210
1/SPA85	0.6	1210
1/SPA90	0.7	1210
1/SPA95	0.8	1210
1/SPA100	0.8	1610
1/SPA106	0.9	1610
1/SPA112	1.0	1610
1/SPA118	1.2	1610
1/SPA125	1.4	1610
1/SPA132	1.6	1610
1/SPA140	1.8	1610
1/SPA150	1.4	1610
1/SPA160	1.9	1610
1/SPA170	2.0	1610
1/SPA180	2.1	1610
1/SPA190	2.3	1610
1/SPA200	2.6	2012
1/SPA212	2.7	2012
1/SPA224	2.7	2012
1/SPA236	2.8	2012
1/SPA250	2.9	2012
1/SPA280	3.3	2012
1/SPA315	3.6	2012
1/SPA355	4.2	2012
1/SPA400	4.9	2012
1/SPA450	7.0	2012
1/SPA500	8.0	2517
1/SPA560	11.6	2517
1/SPA630	10.1	2517

2 GROOVES		
PART NUMBER	WEIGHT (LBS)	BUSHING
2/SPA63*	0.8	1008
2/SPA67*	0.5	1108
2/SPA71*	0.6	1108
2/SPA75*	0.3	1108
2/SPA80*	0.6	1210
2/SPA85	0.7	1210
2/SPA90	0.7	1610
2/SPA95	0.9	1610
2/SPA100	0.9	1610
2/SPA106	1.1	1610
2/SPA112	1.2	1610
2/SPA118	1.4	1610
2/SPA125	1.7	1610
2/SPA132	1.8	2012
2/SPA140	2.0	2012
2/SPA150	2.4	2012
2/SPA160	2.9	2012
2/SPA170	3.1	2012
2/SPA180	3.4	2012
2/SPA190	3.8	2012
2/SPA200	4.1	2517
2/SPA212	4.3	2517
2/SPA224	4.4	2517
2/SPA236	4.6	2517
2/SPA250	4.8	2517
2/SPA280	5.4	2517
2/SPA315	6.0	2517
2/SPA355	6.7	2517
2/SPA400	8.1	2517
2/SPA450	10.3	2517
2/SPA500	11.6	2517
2/SPA560	15.5	3020
2/SPA630	16.0	3020

3 GROOVE		
PART NUMBER	WEIGHT (LBS)	BUSHING
3/SPA71*	0.8	1108
3/SPA75*	0.4	1108
3/SPA80*	0.9	1210
3/SPA85	1.0	1210
3/SPA90	1.0	1610
3/SPA95	1.1	1610
3/SPA100	1.2	1610
3/SPA106	1.4	1610
3/SPA112	1.3	2012
3/SPA118	1.8	2012
3/SPA125	2.0	2012
3/SPA132	2.3	2012
3/SPA140	2.8	2517
3/SPA150	3.5	2517
3/SPA160	3.9	2517
3/SPA170	4.6	2517
3/SPA180	5.1	2517
3/SPA190	5.4	2517
3/SPA200	4.9	2517
3/SPA212	5.2	2517
3/SPA224	5.5	2517
3/SPA236	5.7	2517
3/SPA250	5.9	2517
3/SPA280	6.7	2517
3/SPA315	8.3	3020
3/SPA355	9.2	3020
3/SPA400	11	3020
3/SPA450	14.1	3020
3/SPA500	16.0	3020
3/SPA560	17.8	3020
3/SPA630	22.0	3020

\*ONLY FOR SECTION 13

**KS SHEAVES SPA**  
SHEAVES & BUSHINGS



**ADDITIONAL SIZES AVAILABLE.  
CONTACT AN OPTIBELT  
REPRESENTATIVE FOR MORE  
INFORMATION**



**EXAMPLE SIZING:**

Part Number: 1/SPA71

1 = Number of Grooves SPA = Belt Section Size  
Z1 = Datum Sheave Diameter (MM)

Part Number: 2/SPA125

2 = Number of Grooves SPA = Belt Section Size  
Z125 = Datum Sheave Diameter (MM)

Part Number: 3/SPA315

3 = Number of Grooves SPA = Belt Section Size  
Z315 = Datum Sheave Diameter (MM)





**SPA/13 SECTIONS**

4 GROOVE		
PART NUMBER	WEIGHT (LBS)	BUSHING
4/SPA90	1.2	1615
4/SPA95	1.4	1615
4/SPA100	1.7	1610
4/SPA106	2.0	2012
4/SPA112	1.9	2012
4/SPA118	2.0	2012
4/SPA125	2.5	2012
4/SPA132	2.6	2517
4/SPA140	3.1	2517
4/SPA150	3.8	2517
4/SPA160	4.4	2517
4/SPA170	5.5	2517
4/SPA180	5.9	2517
4/SPA190	6.8	2517
4/SPA200	7.4	3020
4/SPA212	7.3	3020
4/SPA224	7.4	3020
4/SPA236	7.8	3020
4/SPA250	8.0	3020
4/SPA280	8.8	3020
4/SPA315	9.7	3020
4/SPA355	11.0	3020
4/SPA400	12.8	3020
4/SPA450	15.5	3020
4/SPA500	18.2	3020
4/SPA560	26.7	3535
4/SPA630	30.8	3535

5 GROOVE		
PART NUMBER	WEIGHT (LBS)	BUSHING
5/SPA100	1.9	1610
5/SPA106	2.0	2012
5/SPA112	2.1	2012
5/SPA118	2.4	2012
5/SPA125	2.7	2012
5/SPA132	2.9	2517
5/SPA140	3.4	2517
5/SPA150	4.2	2517
5/SPA160	5.1	2517
5/SPA170	5.9	3020
5/SPA180	6.2	3020
5/SPA190	7.4	3020
5/SPA200	8.4	3020
5/SPA212	8.2	3020
5/SPA224	8.3	3020
5/SPA236	8.7	3020
5/SPA250	9.0	3020
5/SPA280	15.5	3535
5/SPA315	17.0	3535
5/SPA355	18.6	3535
5/SPA400	21.0	3535
5/SPA450	24.3	3535
5/SPA500	27.3	3535
5/SPA560	30.4	3535
5/SPA630	33.7	3535
4/SPA630	30.8	3535

**KS SHEAVES SPA**  
SHEAVES & BUSHINGS

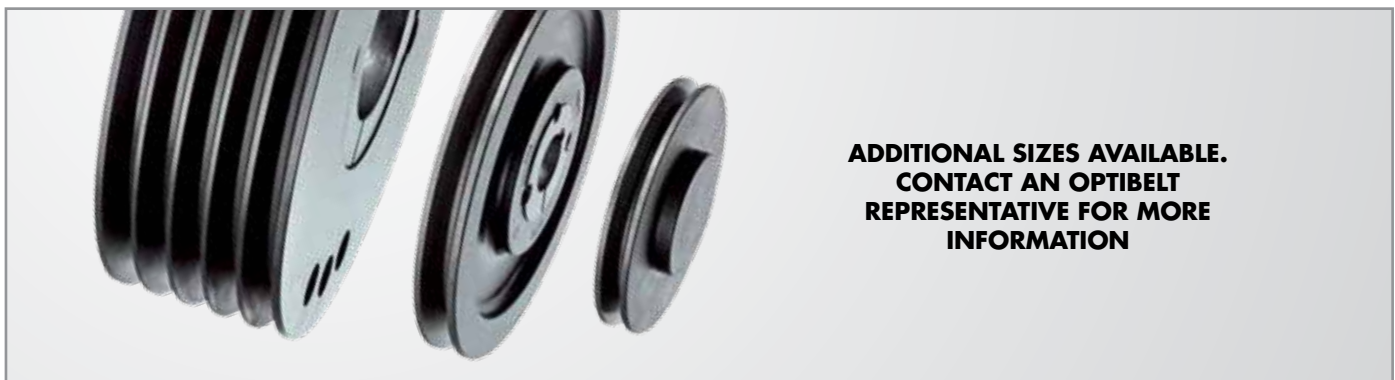

**ADDITIONAL SIZES AVAILABLE.  
CONTACT AN OPTIBELT  
REPRESENTATIVE FOR MORE  
INFORMATION**

<p><b>EXAMPLE SIZING:</b> Part Number: 4/SPA106 4 = Number of Grooves SPA Belt Section Size 106 = Datum Sheave Diameter (MM)</p>	<p>Part Number: 4/SPA400 4 = Number of Grooves SPA = Belt Section Size 400 = Datum Sheave Diameter (MM)</p>	<p>Part Number: 5/SPA170 5 = Number of Grooves SPA = Belt Section Size 170 = Datum Sheave Diameter (MM)</p>
----------------------------------------------------------------------------------------------------------------------------------------------	---------------------------------------------------------------------------------------------------------------------	---------------------------------------------------------------------------------------------------------------------



**SPB/17 SECTIONS**

1 GROOVE		
PART NUMBER	WEIGHT (LBS)	BUSHING
1/SPB100*	0.9	1610
1/SPB112*	1.1	1610
1/SPB118*	1.3	1610
1/SPB125*	1.5	1610
1/SPB132*	1.8	1610
1/SPB140	2.3	1610
1/SPB150	2.7	1610
1/SPB160	2.5	1610
1/SPB170	2.9	1610
1/SPB180	4.1	1610
1/SPB190	4.6	2012
1/SPB200	5.0	2012
1/SPB212	4.2	2012
1/SPB224	4.7	2012
1/SPB236	5.0	2012
1/SPB250	5.4	2012
1/SPB280	6.1	2012
1/SPB315	7.2	2012

\*ONLY FOR SECTION 17

2 GROOVE		
PART NUMBER	WEIGHT (LBS)	BUSHING
2/SPB100*	1.2	1610
2/SPB112*	1.5	1610
2/SPB118*	1.7	1610
2/SPB125*	1.9	2012
2/SPB132*	2.2	2012
2/SPB140	2.7	2012
2/SPB150	3.1	2012
2/SPB160	2.9	2012
2/SPB170	3.3	2012
2/SPB180	4.5	2517
2/SPB190	5.0	2517
2/SPB200	5.4	2517
2/SPB212	4.9	2517
2/SPB224	5.3	2517
2/SPB236	5.5	2517
2/SPB250	5.5	2517
2/SPB265	6.2	2517
2/SPB280	6.8	2517
2/SPB300	7.3	2517
2/SPB315	7.8	2517
2/SPB335	7.8	2517
2/SPB355	8.7	3020
2/SPB375	9.5	3020
2/SPB400	10.0	3020
2/SPB425	11.5	3020
2/SPB450	12.1	3020
2/SPB500	13.2	3020
2/SPB560	16.5	3030
2/SPB630	18.5	3020

3 GROOVE		
PART NUMBER	WEIGHT (LBS)	BUSHING
3/SPB100*	1.7	1610
3/SPB112*	2.0	1610
3/SPB118*	2.3	1610
3/SPB125*	2.4	2012
3/SPB132*	2.8	2012
3/SPB140	3.3	2012
3/SPB150	3.9	2517
3/SPB160	4.2	2517
3/SPB170	4.9	2517
3/SPB180	5.5	2517
3/SPB190	6.3	2517
3/SPB200	6.5	2517
3/SPB212	6.0	2517
3/SPB224	6.3	2517
3/SPB236	7.0	2517
3/SPB250	7.7	3020
3/SPB265	8.0	3020
3/SPB280	8.6	3020
3/SPB300	9.2	3020
3/SPB315	9.6	3020
3/SPB335	10.5	3020
3/SPB355	10.8	3020
3/SPB375	11.5	3020
3/SPB400	18.3	3535
3/SPB425	18.0	3535
3/SPB450	21.9	3535
3/SPB500	23.1	3535
3/SPB560	25.9	3535
3/SPB630	28.9	3535
3/SPB710	33.2	3535
3/SPB800	36.7	3535
3/SPB900	46.8	3535
3/SPB1000	56.5	4040

**KS SHEAVES SPB**  
SHEAVES & BUSHINGS

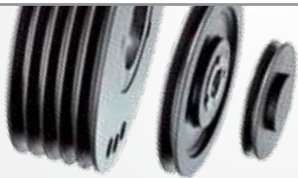

**ADDITIONAL SIZES AVAILABLE.  
CONTACT AN OPTIBELT  
REPRESENTATIVE FOR MORE  
INFORMATION**



**EXAMPLE SIZING:**

Part Number: 1/SPA71

1 = Number of Grooves SPA = Belt Section Size

71 = Datum Sheave Diameter (MM)

1108 = Bushing Size

Part Number: 2/SPA125

2 = Number of Grooves SPA = Belt Section Size

125 = Datum Sheave Diameter (MM)

1610 = Bushing Size

Part Number: 3/SPA315

3 = Number of Grooves SPA = Belt Section Size

315 = Datum Sheave Diameter (MM)

3020 = Bushing Size



**SPB/17 SECTIONS**

4 GROOVE		
PART NUMBER	WEIGHT (LBS)	BUSHING
4/SPB125*	3.0	2012
4/SPB132*	3.4	2012
4/SPB140	3.7	2517
4/SPB150	4.4	2517
4/SPB160	4.9	2517
4/SPB170	5.7	2517
4/SPB180	6.9	2517
4/SPB190	7.6	2517
4/SPB200	8.8	3020
4/SPB212	9.8	3020
4/SPB224	11.3	3020
4/SPB236	14.5	3020
4/SPB250	19.6	3020
4/SPB265	9.5	3020
4/SPB280	10.1	3020
4/SPB300	14.3	3020
4/SPB315	17.1	3535
4/SPB335	18.3	3535
4/SPB355	18.6	3535
4/SPB375	16.5	3525
4/SPB400	20.5	3535
4/SPB425	19.5	3535
4/SPB450	24.5	3535
4/SPB500	26.6	3535
4/SPB560	29.0	3535
4/SPB630	33.3	3535
4/SPB710	39.1	3535
4/SPB800	48.8	4040
4/SPB900	60.0	4040
4/SPB1000	66.5	4040

5 GROOVE		
PART NUMBER	WEIGHT (LBS)	BUSHING
5/SPB125*	3.5	2012
5/SPB132*	3.7	2012
5/SPB140	4.5	2517
5/SPB150	5.2	2517
5/SPB160	6.0	2517
5/SPB170	6.1	3020
5/SPB180	7.1	3020
5/SPB190	8.1	3020
5/SPB200	9.1	3020
5/SPB212	11.0	3020
5/SPB224	12.7	3020
5/SPB236	16.9	3535
5/SPB250	21.7	3535
5/SPB280	17.8	3535
5/SPB300	18.2	3535
5/SPB315	18.8	3535
5/SPB335	19.5	3535
5/SPB355	20.8	3535
5/SPB400	23.4	3535
5/SPB450	27.3	3535
5/SPB500	29.9	3535
5/SPB560	35.3	4040
5/SPB630	43.1	4040
5/SPB710	50.2	4040
5/SPB800	56.1	4040
5/SPB900	74.8	4545
5/SPB1000	80.5	4545

6 GROOVE		
PART NUMBER	WEIGHT (LBS)	BUSHING
6/SPB140	4.6	2517
6/SPB150	5.6	2517
6/SPB160	5.4	3020
6/SPB170	6.5	3020
6/SPB180	7.7	3020
6/SPB190	9.2	3020
6/SPB200	10.3	3020
6/SPB212	14.3	3535
6/SPB224	17.0	3535
6/SPB236	20.0	3535
6/SPB250	23.3	3535
6/SPB265	16.7	3525
6/SPB280	19.6	3535
6/SPB300	21.9	3535
6/SPB315	23.0	3535
6/SPB335	22.0	3535
6/SPB355	22.8	3535
6/SPB375	25.0	3525
6/SPB400	25.1	3535
6/SPB425	25.1	4040
6/SPB450	35.5	4040
6/SPB500	38.9	4040
6/SPB560	43.1	4040
6/SPB630	49.2	4040
6/SPB710	62.3	4545
6/SPB800	71.4	4545
6/SPB900	81.5	4545
6/SPB1000	90.0	4545

\*ONLY FOR SECTION 17

KS SHEAVES SPB  
SHEAVES & BUSHINGS



**ADDITIONAL SIZES AVAILABLE.  
CONTACT AN OPTIBELT  
REPRESENTATIVE FOR MORE  
INFORMATION**

**EXAMPLE SIZING:**

Part Number: 4/SPB200

4 = Number of Grooves SPB = Belt Section Size  
200 = Datum Sheave Diameter (MM)

Part Number: 5/SPB900

5 = Number of Grooves SPB = Belt Section Size  
900 = Datum Sheave Diameter (MM)

Part Number: 6/SPB212

6 = Number of Grooves SPB = Belt Section Size  
212 = Datum Sheave Diameter (MM)



**SPB/17 SECTIONS**

8 GROOVE		
PART NUMBER	WEIGHT (LBS)	BUSHING
8/SPB170	8.0	3020
8/SPB180	9.5	3020
8/SPB190	11.2	3030
8/SPB200	13.5	3535
8/SPB212	16.6	3535
8/SPB224	19.3	3535
8/SPB236	22.3	3535
8/SPB250	27.5	3535
8/SPB265	24.0	3525
8/SPB280	26.7	3535
8/SPB300	26.2	3535
8/SPB315	26.0	3535
8/SPB335	28.2	3535
8/SPB355	27.0	3535
8/SPB375	28.0	3525
8/SPB400	36.5	4040
8/SPB425	52.5	4545
8/SPB450	40.9	4040
8/SPB500	45.5	4040
8/SPB560	49.0	4545
8/SPB630	62.0	4545
8/SPB710	71.0	4545
8/SPB800	90.9	4545
8/SPB900	110.0	4545
8/SPB1000	132.0	5050

10 GROOVE		
PART NUMBER	WEIGHT (LBS)	BUSHING
10/SPB224	21.8	3535
10/SPB236	25.3	3535
10/SPB250	29.3	3535
10/SPB280	30.5	3535
10/SPB315	31.5	3535
10/SPB335	36.0	4040
10/SPB355	38.0	4040
10/SPB400	41.0	4040
10/SPB450	53.5	4545
10/SPB500	61.0	4545
10/SPB560	55.7	4545
10/SPB630	72.0	4545
10/SPB710	80.0	4545
10/SPB800	102.0	4545
10/SPB900	126.0	5050
10/SPB1000	147.0	5050

**KS SHEAVES SPB**  
SHEAVES & BUSHINGS

**ADDITIONAL SIZES AVAILABLE.  
CONTACT AN OPTIBELT  
REPRESENTATIVE FOR MORE  
INFORMATION**



**EXAMPLE SIZING:**

Part Number: 8/SPB180/3020  
8 = Number of Sheaves SPB = Belt Section Size  
180 = Datum Sheave Diameter (MM)

Part Number: 8/SPB335  
8 = Number of Grooves SPB = Belt Section Size  
335 = Datum Sheave Diameter (MM)

Part Number: 10/SPB315  
10 = Number of Grooves SPB = Belt Section Size  
315 = Datum Sheave Diameter (MM)



### SPC/22 SECTIONS

3 GROOVE		
PART NUMBER	WEIGHT (LBS)	BUSHING
3/SPC200*	9.0	2517
3/SPC212*	10.0	3020
3/SPC224	11.0	3020
3/SPC236	12.0	3020
3/SPC250	14.5	3020
3/SPC265	21.2	3535
3/SPC280	24.0	3535
3/SPC300	21.0	3535
3/SPC315	21.6	3535
3/SPC335	22.5	3535
3/SPC355	22.9	3535
3/SPC375	23.8	3535
3/SPC400	24.1	3535
3/SPC425	26.0	3535
3/SPC450	28.6	3535
3/SPC475	40.0	3535
3/SPC500	30.9	3535
3/SPC560	36.0	3535
3/SPC630	48.5	4040

4 GROOVE		
PART NUMBER	WEIGHT (LBS)	BUSHING
4/SPC200*	10.5	3020
4/SPC212*	12.5	3020
4/SPC224	14.0	3535
4/SPC236	17.2	3535
4/SPC250	20.7	3535
4/SPC265	24.0	3535
4/SPC280	29.0	3535
4/SPC300	25.0	3535
4/SPC315	24.6	3535
4/SPC335	26.5	3535
4/SPC355	28.3	3535
4/SPC375	30.0	3535
4/SPC400	28.0	3535
4/SPC425	31.0	3535
4/SPC450	33.5	3535
4/SPC475	47.0	3535
4/SPC500	39.0	3535
4/SPC560	50.0	4040
4/SPC630	61.0	4545

5 GROOVE		
PART NUMBER	WEIGHT (LBS)	BUSHING
5/SPC200*	14.0	3535
5/SPC212*	15.0	3535
5/SPC224	16.2	3535
5/SPC236	19.1	3535
5/SPC250	22.8	3535
5/SPC265	26.2	3535
5/SPC280	31.0	3535
5/SPC300	28.5	3535
5/SPC315	29.0	3535
5/SPC335	30.0	3535
5/SPC355	32.5	3535
5/SPC375	33.0	3535
5/SPC400	34.0	3535
5/SPC425	45.0	4040
5/SPC450	45.0	4040
5/SPC475	47.2	4040
5/SPC500	48.7	4040
5/SPC560	63.0	4545
5/SPC630	77.0	5050

\*ONLY FOR SECTION 22 1000 & 1250 Datum diameter available in 5, 6, 8, 10 grooves in 5050 taper bush.

KS SHEAVES SPC  
SHEAVES & BUSHINGS



**ADDITIONAL SIZES AVAILABLE.  
CONTACT AN OPTIBELT  
REPRESENTATIVE FOR MORE  
INFORMATION**

**EXAMPLE SIZING:**

Part Number: 3/SPC280

3 = Number of Grooves SPC = Belt Section Size  
280 = Datum Sheave Diameter (MM)

Part Number: 4/SPC450

4 = Number of Grooves SPC = Belt Section Size  
450 = Datum Sheave Diameter (MM)

Part Number: 5/SPC212

5 = Number of Grooves SPC = Belt Section Size  
212 = Datum Sheave Diameter (MM)



**SPB/17 SECTIONS**

6 GROOVE		
PART NUMBER	WEIGHT (LBS)	BUSHING
6/SPC200*	17.0	3535
6/SPC212*	18.0	3535
6/SPC224	19.0	3535
6/SPC236	20.8	3535
6/SPC250	26.0	3535
6/SPC265	29.0	3535
6/SPC280	33.8	3535
6/SPC300	29.0	3535
6/SPC315	31.4	3535
6/SPC335	35.0	3535
6/SPC355	36.0	3535
6/SPC375	45.5	4040
6/SPC425	58.0	4545
6/SPC450	61.1	4545
6/SPC475	62.8	4545
6/SPC500	60.2	4545
6/SPC560	77.0	5050
6/SPC630	86.0	5050

8 GROOVE		
PART NUMBER	WEIGHT (LBS)	BUSHING
8/SPC224	24.9	3535
8/SPC236	25.5	3535
8/SPC250	29.7	3535
8/SPC265	33.3	3535
8/SPC280	37.5	3535
8/SPC300	46.5	4040
8/SPC315	50.0	4040
8/SPC335	58.0	4040
8/SPC355	67.5	4040
8/SPC375	68.0	4545
8/SPC425	74.0	4545
8/SPC450	78.7	5050
8/SPC475	81.5	5050
8/SPC500	87.4	5050
8/SPC560	94.0	5050
8/SPC630	105.5	5050

10 GROOVE		
PART NUMBER	WEIGHT (LBS)	BUSHING
10/SPC250	34.0	4040
10/SPC280	45.0	4040
10/SPC300	53.5	4545
10/SPC315	58.0	4545
10/SPC355	98.0	4545
10/SPC450	101.0	5050
10/SPC500	127.0	5050
10/SPC560	115.0	5050
10/SPC630	130.0	5050

\*ONLY FOR SECTION 22

**KS SHEAVES SPC**  
SHEAVES & BUSHINGS

**ADDITIONAL SIZES AVAILABLE.  
CONTACT AN OPTIBELT  
REPRESENTATIVE FOR MORE  
INFORMATION**



**EXAMPLE SIZING:**

Part Number: 6/SPC250

6 = Number of Grooves SPC = Belt Section Size  
250 = Datum Sheave Diameter (MM)

Part Number: 8/SPC560

8 = Number of Grooves SPC = Belt Section Size  
560 = Datum Sheave Diameter (MM)

Part Number: 10/SPC300

10 = Number of Grooves SPC = Belt Section Size  
300 = Datum Sheave Diameter (MM)

# 3L & 4L/A

BORE TO SIZE

# optibelt KS

BUSHING SHEAVES



3L & 4L/A SECTIONS			
PART NUMBER	OUTSIDE DIAMETER (IN.)	3L PITCH DIAMETER (IN.)	4L/A PITCH DIAMETER (IN.)
AK17-1/2	1.75	1.16	1.50
AK17-5/8	1.75	1.16	1.50
AK20-1/2	2.00	1.46	1.80
AK20-3/4	2.00	1.46	1.80
AK20-5/8	2.00	1.46	1.80
AK21-1/2	2.10	1.56	1.90
AK21-3/4	2.10	1.56	1.90
AK21-5/8	2.10	1.56	1.90
AK22-1/2	2.20	1.66	2.00
AK22-3/4	2.20	1.66	2.00
AK22-5/8	2.20	1.66	2.00
AK23-1/2	2.30	1.76	2.10
AK23-3/4	2.30	1.76	2.10
AK23-5/8	2.30	1.76	2.10
AK23-7/8	2.30	1.76	2.10
AK25-1/2	2.50	1.96	2.30
AK25-3/4	2.50	1.96	2.30
AK25-5/8	2.50	1.96	2.30
AK25-7/8	2.50	1.96	2.30
AK26-1/2	2.60	2.06	2.40
AK26-3/4	2.60	2.06	2.40
AK26-5/8	2.60	2.06	2.40
AK26-7/8	2.60	2.06	2.40
AK27-1/2	2.70	2.16	2.50
AK27-3/4	2.70	2.16	2.50
AK27-5/8	2.70	2.16	2.50
AK27-7/8	2.70	2.16	2.50
AK28-1	2.80	2.26	2.60
AK28-1/2	2.80	2.26	2.60
AK28-3/4	2.80	2.26	2.60
AK28-5/8	2.80	2.26	2.60
AK28-7/8	2.80	2.26	2.60
AK30-1	3.05	2.46	2.80
AK30-1/2	3.05	2.46	2.80
AK30-3/4	3.05	2.46	2.80
AK30-5/8	3.05	2.46	2.80
AK30-7/8	3.05	2.46	2.80
AK32-1	3.25	2.66	3.00
AK32-1/2	3.25	2.66	3.00
AK32-3/4	3.25	2.66	3.00
AK32-5/8	3.25	2.66	3.00
AK32-7/8	3.25	2.66	3.00

3L & 4L/A SECTIONS			
PART NUMBER	OUTSIDE DIAMETER (IN.)	4L & A PITCH DIAMETER (IN.)	5L & B PITCH DIAMETER (IN.)
AK34-1	3.45	2.86	3.20
AK34-1/2	3.45	2.86	3.20
AK34-3/4	3.45	2.86	3.20
AK34-5/8	3.45	2.86	3.20
AK34-7/8	3.45	2.86	3.20
AK39-1	3.75	3.16	3.50
AK39-1/2	3.75	3.16	3.50
AK39-1-1/8	3.75	3.16	3.50
AK39-15/16	3.75	3.16	3.50
AK39-3/4	3.75	3.16	3.50
AK39-3/4 W/2	3.75	3.16	3.50
AK39-5/8	3.75	3.16	3.50
AK39-7/8	3.75	3.16	3.50
AK41-1	3.95	3.36	3.70
AK41-1/2	3.95	3.36	3.70
AK41-15/16	3.95	3.36	3.70
AK41-3/4	3.95	3.36	3.70
AK41-5/8	3.95	3.36	3.70
AK41-7/8	3.95	3.36	3.70
AK44-1	4.25	3.66	4.00
AK44-1/2	4.25	3.66	4.00
AK44-1-1/8	4.25	3.66	4.00
AK44-15/16	4.25	3.66	4.00
AK44-3/4	4.25	3.66	4.00
AK44-5/8	4.25	3.66	4.00
AK44-7/8	4.25	3.66	4.00
AK46-1	4.45	3.86	4.20
AK46-1/2	4.45	3.86	4.20
AK46-1-1/8	4.45	3.86	4.20
AK46-15/16	4.45	3.86	4.20
AK46-3/4	4.45	3.86	4.20
AK46-5/8	4.45	3.86	4.20
AK46-7/8	4.45	3.86	4.20
AK49-1	4.75	4.16	4.50
AK49-1/2	4.75	4.16	4.50
AK49-1-1/8	4.75	4.16	4.50
AK49-15/16	4.75	4.16	4.50
AK49-3/4	4.75	4.16	4.50
AK49-5/8	4.75	4.16	4.50
AK49-7/8	4.75	4.16	4.50

KS 3L 4L/A  
SHEAVES & BUSHINGS

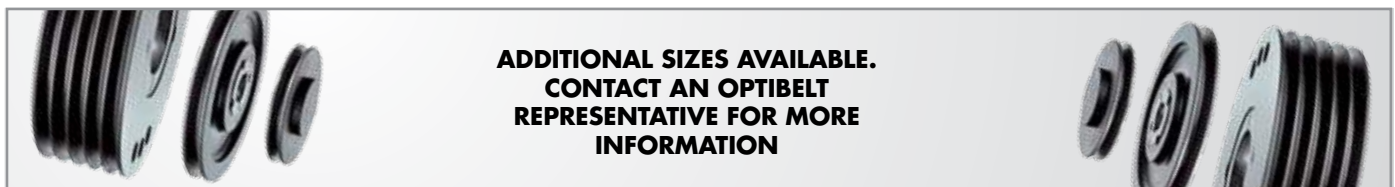

**ADDITIONAL SIZES AVAILABLE.  
CONTACT AN OPTIBELT  
REPRESENTATIVE FOR MORE  
INFORMATION**



**optibelt KS**  
BUSHING SHEAVES

**3L & 4L/A SECTIONS**

BORE TO SIZE

**KS 3L 4L/A**  
SHEAVES & BUSHINGS

3L & 4L/A SECTIONS			
PART NUMBER	OUTSIDE DIAMETER (IN.)	4L & A PITCH DIAMETER (IN.)	5L & B PITCH DIAMETER (IN.)
AK51-1	4.95	4.36	4.70
AK51-1/2	4.95	4.36	4.70
AK51-1-1/8	4.95	4.36	4.70
AK51-3/4	4.95	4.36	4.70
AK51-5/8	4.95	4.36	4.70
AK51-7/8	4.95	4.36	4.70
AK54-1	5.25	4.66	5.00
AK54-1/2	5.25	4.66	5.00
AK54-1-1/8	5.25	4.66	5.00
AK54-1-3/16	5.25	4.66	5.00
AK54-15/16	5.25	4.66	5.00
AK54-3/4	5.25	4.66	5.00
AK54-5/8	5.25	4.66	5.00
AK54-7/8	5.25	4.66	5.00
AK56-1	5.45	4.86	5.20
AK56-1/2	5.45	4.86	5.20
AK56-1-1/8	5.45	4.86	5.20
AK56-1-3/16	5.45	4.86	5.20
AK56-15/16	5.45	4.86	5.20
AK56-3/4	5.45	4.86	5.20
AK56-5/8	5.45	4.86	5.20
AK56-7/8	5.45	4.86	5.20
AK59-1	5.75	5.16	5.50
AK59-1/2	5.75	5.16	5.50
AK59-1-1/8	5.75	5.16	5.50
AK59-1-3/16	5.75	5.16	5.50
AK59-15/16	5.75	5.16	5.50
AK59-3/4	5.75	5.16	5.50
AK59-5/8	5.75	5.16	5.50
AK59-7/8	5.75	5.16	5.50
AK61-1	5.95	5.36	5.70
AK61-1/2	5.95	5.36	5.70
AK61-1-1/8	5.95	5.36	5.70
AK61-1-3/16	5.95	5.36	5.70
AK61-15/16	5.95	5.36	5.70
AK61-3/4	5.95	5.36	5.70
AK61-5/8	5.95	5.36	5.70
AK61-7/8	5.95	5.36	5.70
AK64-1	6.25	5.66	6.00
AK64-1/2	6.25	5.66	6.00
AK64-1-1/8	6.25	5.66	6.00
AK64-1-3/16	6.25	5.66	6.00
AK64-15/16	6.25	5.66	6.00
AK64-3/4	6.25	5.66	6.00
AK64-5/8	6.25	5.66	6.00
AK64-7/8	6.25	5.66	6.00

3L & 4L/A SECTIONS			
PART NUMBER	OUTSIDE DIAMETER (IN.)	4L & A PITCH DIAMETER (IN.)	5L & B PITCH DIAMETER (IN.)
AK66-1	6.45	5.86	6.20
AK66-1-1/8	6.45	5.86	6.20
AK66-3/4	6.45	5.86	6.20
AK66-5/8	6.45	5.86	6.20
AK69-1	6.75	6.16	6.50
AK69-1-1/8	6.75	6.16	6.50
AK69-3/4	6.75	6.16	6.50
AK71-1	6.95	6.36	6.70
AK71-1-1/8	6.95	6.36	6.70
AK71-1-7/16	6.95	6.36	6.70
AK71-3/4	6.95	6.36	6.70
AK71-5/8	6.95	6.36	6.70
AK71-7/8	6.95	6.36	6.70
AK74-1	7.25	6.66	7.00
AK74-1/2	7.25	6.66	7.00
AK74-1-1/4	7.25	6.66	7.00
AK74-1-1/8	7.25	6.66	7.00
AK74-1-3/16	7.25	6.66	7.00
AK74-15/16	7.25	6.66	7.00
AK74-1-7/16	7.25	6.66	7.00
AK74-3/4	7.25	6.66	7.00
AK74-5/8	7.25	6.66	7.00
AK79-1	7.75	7.16	7.50
AK79-1-1/8	7.75	7.16	7.50
AK79-1-7/16	7.75	7.16	7.50
AK79-3/4	7.75	7.16	7.50
AK84-1	8.25	7.66	8.00
AK84-1/2	8.25	7.66	8.00
AK84-1-3/16	8.25	7.66	8.00
AK84-15/16	8.25	7.66	8.00
AK84-1-7/16	8.25	7.66	8.00
AK84-3/4	8.25	7.66	8.00
AK84-5/8	8.25	7.66	8.00
AK89-1	8.75	8.16	8.50
AK89-1-1/8	8.75	8.16	8.50
AK89-1-7/16	8.75	8.16	8.50
AK89-3/4	8.75	8.16	8.50
AK94-1	9.25	8.66	9.00
AK94-1/2	9.25	8.66	9.00
AK94-1-1/4	9.25	8.66	9.00
AK94-1-3/16	9.25	8.66	9.00
AK94-15/16	9.25	8.66	9.00
AK94-1-7/16	9.25	8.66	9.00
AK94-3/4	9.25	8.66	9.00
AK94-5/8	9.25	8.66	9.00

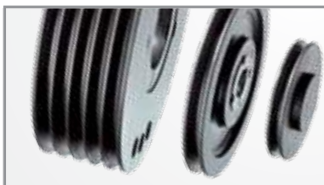

**ADDITIONAL SIZES AVAILABLE.  
CONTACT AN OPTIBELT  
REPRESENTATIVE FOR MORE  
INFORMATION**





# 3L & 4L/A SECTIONS

BORE TO SIZE

**optibelt KS**  
BUSHINGS SHEAVES



3L & 4L/A SECTIONS			
PART NUMBER	OUTSIDE DIAMETER (IN.)	3L PITCH DIAMETER (IN.)	4L/A PITCH DIAMETER (IN.)
AK99-1	9.75	9.16	9.50
AK99-1-7/16	9.75	9.16	9.50
AK99-3/4	9.75	9.16	9.50
AK104-1	10.25	9.66	10.00
AK104-1-1/4	10.25	9.66	10.00
AK104-1-3/16	10.25	9.66	10.00
AK104-1-3/8	10.25	9.66	10.00
AK104-1-7/16	10.25	9.66	10.00
AK104-3/4	10.25	9.66	10.00
AK104-5/8	10.25	9.66	10.00
AK109-1	10.75	10.16	11.00
AK109-1-3/8	10.75	10.16	11.00
AK109-1-7/16	10.75	10.16	11.00
AK109-3/4	10.75	10.16	11.00
AK114-1	11.25	10.66	11.00
AK114-1-3/16	11.25	10.66	11.00
AK114-1-7/16	11.25	10.66	11.00
AK114-3/4	11.25	10.66	11.00
AK124-1	12.25	11.66	12.00
AK124-1-1/4	12.25	11.66	12.00
AK124-1-3/16	12.25	11.66	12.00
AK124-1-7/16	12.25	11.66	12.00
AK124-3/4	12.25	11.66	12.00
AK124-5/8	12.25	11.66	12.00
AK124-7/8	12.25	11.66	12.00
AK134-1	13.25	12.66	13.00
AK134-1-3/16	13.25	12.66	13.00
AK134-1-3/8	13.25	12.66	13.00
AK134-1-7/16	13.25	12.66	13.00
AK134-3/4	13.25	12.66	13.00

3L & 4L/A SECTIONS			
PART NUMBER	OUTSIDE DIAMETER (IN.)	4L & A PITCH DIAMETER (IN.)	5L & B PITCH DIAMETER (IN.)
AK144-1	14.25	13.66	14.00
AK144-1-3/16	14.25	13.66	14.00
AK144-1-7/16	14.25	13.66	14.00
AK144-3/4	14.25	13.66	14.00
AK154-1	15.25	14.66	15.00
AK154-1-3/16	15.25	14.66	15.00
AK154-1-3/8	15.25	14.66	15.00
AK154-1-7/16	15.25	14.66	15.00
AK154-3/4	15.25	14.66	15.00
AK184-1	18.25	17.66	18.00
AK184-1-3/16	18.25	17.66	18.00
AK184-1-7/16	18.25	17.66	18.00
AK184-3/4	18.25	17.66	18.00

STANDARD KEY DIMENSIONS	
SHAFT DIAMETER	KEYSEAT (WIDTH X DEPTH)
1/2	None
5/8-7/8	3/16 x 3/32
15/16-1 1/4	1/4 x 1/8
1-5/16-1 3/8	5/16 x 5/32
1-7/16-1 3/4	3/8 x 3/16

KS 3L 4L/A  
SHEAVES & BUSHINGS



**ADDITIONAL SIZES AVAILABLE.  
CONTACT AN OPTIBELT  
REPRESENTATIVE FOR MORE  
INFORMATION**



**optibelt KS**  
BUSHING SHEAVES

**3L & 4L/A SECTIONS**

BORE TO SIZE

**KS 3L 4L/A**  
SHEAVES & BUSHINGS

3L & 4L/A SECTIONS			
PART NUMBER	OUTSIDE DIAMETER (IN.)	4L & A PITCH DIAMETER (IN.)	5L & B PITCH DIAMETER (IN.)
2AK20-1/2	2.00	1.46	1.80
2AK20-3/4	2.00	1.46	1.80
2AK20-5/8	2.00	1.46	1.80
2AK20-7/8	2.00	1.46	1.80
2AK21-1/2	2.10	1.56	1.90
2AK21-3/4	2.10	1.56	1.90
2AK21-5/8	2.10	1.56	1.90
2AK22-1/2	2.20	1.66	2.00
2AK22-3/4	2.20	1.66	2.00
2AK22-5/8	2.20	1.66	2.00
2AK22-7/8	2.20	1.66	2.00
2AK23-1	2.30	1.76	2.10
2AK23-3/4	2.30	1.76	2.10
2AK23-5/8	2.30	1.76	2.10
2AK23-7/8	2.30	1.76	2.10
2AK25-1	2.50	1.96	2.30
2AK25-3/4	2.50	1.96	2.30
2AK25-5/8	2.50	1.96	2.30
2AK25-7/8	2.50	1.96	2.30
2AK26-1	2.60	2.06	2.40
2AK26-3/4	2.60	2.06	2.40
2AK26-5/8	2.60	2.06	2.40
2AK26-7/8	2.60	2.06	2.40
2AK27-1	2.70	2.16	2.50
2AK27-3/4	2.70	2.16	2.50
2AK27-5/8	2.70	2.16	2.50
2AK27-7/8	2.70	2.16	2.50
2AK28-1	2.80	2.26	2.60
2AK28-3/4	2.80	2.26	2.60
2AK28-5/8	2.80	2.26	2.60
2AK28-7/8	2.80	2.26	2.60
2AK30-1	3.05	2.46	2.80
2AK30-1/2	3.05	2.46	2.80
2AK30-1-1/8	3.05	2.46	2.80
2AK30-3/4	3.05	2.46	2.80
2AK30-5/8	3.05	2.46	2.80
2AK30-7/8	3.05	2.46	2.80
2AK32-1	3.25	2.66	3.00
2AK32-1/2	3.25	2.66	3.00
2AK32-1-1/8	3.25	2.66	3.00
2AK32-3/4	3.25	2.66	3.00
2AK32-5/8	3.25	2.66	3.00
2AK32-7/8	3.25	2.66	3.00

3L & 4L/A SECTIONS			
PART NUMBER	OUTSIDE DIAMETER (IN.)	4L & A PITCH DIAMETER (IN.)	5L & B PITCH DIAMETER (IN.)
2AK34-1	3.45	2.86	3.20
2AK34-1/2	3.45	2.86	3.20
2AK34-1-1/8	3.45	2.86	3.20
2AK34-3/4	3.45	2.86	3.20
2AK34-5/8	3.45	2.86	3.20
2AK34-7/8	3.45	2.86	3.20
2AK39-1	3.75	3.16	3.50
2AK39-1/2	3.75	3.16	3.50
2AK39-1-1/8	3.75	3.16	3.50
2AK39-3/4	3.75	3.16	3.50
2AK39-5/8	3.75	3.16	3.50
2AK39-7/8	3.75	3.16	3.50
2AK41-1	3.95	3.36	3.70
2AK41-1-1/8	3.95	3.36	3.70
2AK41-3/4	3.95	3.36	3.70
2AK41-5/8	3.95	3.36	3.70
2AK41-7/8	3.95	3.36	3.70
2AK44-1	4.25	3.66	4.00
2AK44-1-1/8	4.25	3.66	4.00
2AK44-3/4	4.25	3.66	4.00
2AK44-5/8	4.25	3.66	4.00
2AK44-7/8	4.25	3.66	4.00
2AK46-1	4.45	3.86	4.20
2AK46-1-1/8	4.45	3.86	4.20
2AK46-7/8	4.45	3.86	4.20
2AK49-1	4.75	4.16	4.50
2AK49-1-1/8	4.75	4.16	4.50
2AK49-1-3/8	4.75	4.16	4.50
2AK49-3/4	4.75	4.16	4.50
2AK49-7/8	4.75	4.16	4.50
2AK51-1	4.95	4.36	4.70
2AK51-1-1/8	4.95	4.36	4.70
2AK51-1-3/8	4.95	4.36	4.70
2AK51-3/4	4.95	4.36	4.70
2AK51-7/8	4.95	4.36	4.70
2AK54-1	5.25	4.66	5.00
2AK54-1-1/8	5.25	4.66	5.00
2AK54-1-3/8	5.25	4.66	5.00
2AK54-3/4	5.25	4.66	5.00
2AK54-5/8	5.25	4.66	5.00
2AK54-7/8	5.25	4.66	5.00

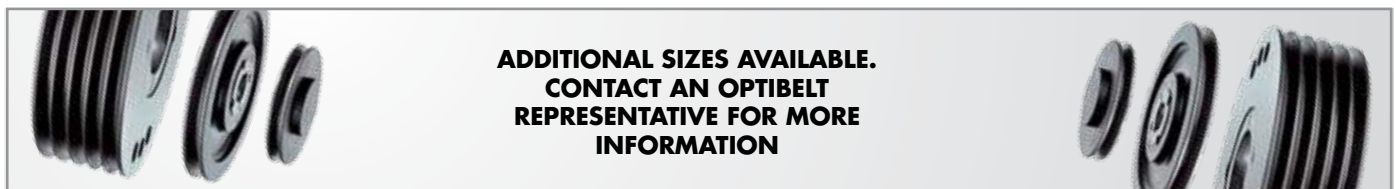

# 3L & 4L/A SECTIONS

BORE TO SIZE

**optibelt KS**  
BUSHINGS SHEAVES



3L & 4L/A SECTIONS			
PART NUMBER	OUTSIDE DIAMETER (IN.)	3L PITCH DIAMETER (IN.)	4L/A PITCH DIAMETER (IN.)
2AK56-1	5.45	4.86	5.20
2AK56-1-1/8	5.45	4.86	5.20
2AK56-1-3/8	5.45	4.86	5.20
2AK56-3/4	5.45	4.86	5.20
2AK56-5/8	5.45	4.86	5.20
2AK59-1	5.75	5.16	5.50
2AK59-1-1/8	5.75	5.16	5.50
2AK59-1-3/8	5.75	5.16	5.50
2AK61-1	5.95	5.36	5.70
2AK61-1-1/8	5.95	5.36	5.70
2AK61-1-3/8	5.95	5.36	5.70
2AK61-3/4	5.95	5.36	5.70
2AK61-7/8	5.95	5.36	5.70
2AK64-1	6.25	5.66	6.00
2AK64-1-1/8	6.25	5.66	6.00
2AK64-1-3/16	6.25	5.66	6.00
2AK64-1-3/8	6.25	5.66	6.00
2AK64-1-7/16	6.25	5.66	6.00
2AK64-3/4	6.25	5.66	6.00
2AK74-1	7.25	6.66	7.00
2AK74-1-1/8	7.25	6.66	7.00
2AK74-1-3/16	7.25	6.66	7.00
2AK74-1-3/8	7.25	6.66	7.00
2AK74-1-7/16	7.25	6.66	7.00
2AK74-3/4	7.25	6.66	7.00
2AK84-1	8.25	7.66	8.00
2AK84-1-1/4	8.25	7.66	8.00
2AK84-1-1/8	8.25	7.66	8.00
2AK84-1-3/16	8.25	7.66	8.00
2AK84-1-3/8	8.25	7.66	8.00
2AK84-15/16	8.25	7.66	8.00
2AK84-1-7/16	8.25	7.66	8.00
2AK84-3/4	8.25	7.66	8.00
2AK94-1	9.25	8.66	9
2AK94-1-1/8	9.25	8.66	9
2AK94-1-3/16	9.25	8.66	9
2AK94-1-3/8	9.25	8.66	9
2AK94-3/4	9.25	8.66	9
2AK104-1	10.25	9.66	10
2AK104-15/16	10.25	9.66	10
2AK104-1-7/16	10.25	9.66	10
2AK104-3/4	10.25	9.66	10

3L & 4L/A SECTIONS			
PART NUMBER	OUTSIDE DIAMETER (IN.)	4L & A PITCH DIAMETER (IN.)	5L & B PITCH DIAMETER (IN.)
2AK114-1	11.25	10.66	11
2AK114-1-3/16	11.25	10.66	11
2AK114-1-3/8	11.25	10.66	11
2AK114-1-7/16	11.25	10.66	11
2AK114-3/4	11.25	10.66	11
2AK124-1	12.25	11.66	12
2AK124-1-3/16	12.25	11.66	12
2AK124-1-7/16	12.25	11.66	12
2AK124-3/4	12.25	11.66	12
2AK134-1-3/16	13.25	12.66	13
2AK134-1-7/16	13.25	12.66	13
2AK144-1	14.25	13.66	14
2AK144-1-7/16	14.25	13.66	14
2AK154-1-3/16	15.25	14.66	15
2AK154-1-7/16	15.25	14.66	15
2AK184-1-3/16	18.25	17.66	18
2AK184-1-7/16	18.25	17.66	18

STANDARD KEY DIMENSIONS	
SHAFT DIAMETER	KEYSEAT (WIDTH X DEPTH)
1/2	None
5/8-7/8	3/16 x 3/32
15/16-1 1/4	1/4 x 1/8
1-5/16-1 3/8	5/16 x 5/32
1-7/16-1 3/4	3/8 x 3/16

KS 3L 4L/A  
SHEAVES & BUSHINGS

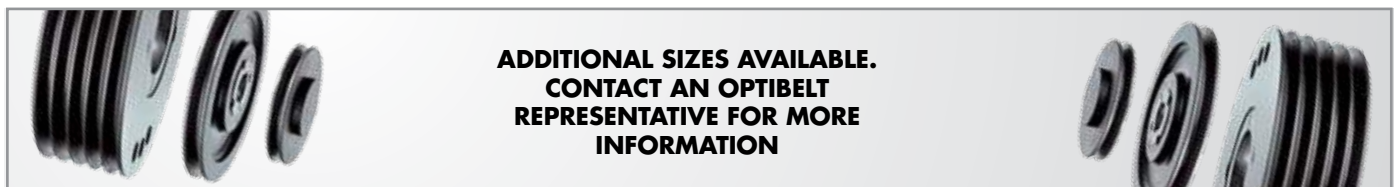

**ADDITIONAL SIZES AVAILABLE.  
CONTACT AN OPTIBELT  
REPRESENTATIVE FOR MORE  
INFORMATION**



**optibelt KS**  
BUSHING SHEAVES

**4L/A & 5L/B SECTIONS**

BORE TO SIZE

**KS 4L/A 5L/B**  
SHEAVES & BUSHINGS

4L/A & 5L/B SECTIONS			
PART NUMBER	OUTSIDE DIAMETER (IN.)	4L & A PITCH DIAMETER (IN.)	5L & B PITCH DIAMETER (IN.)
BK24-1/2	2.4	1.8	2.2
BK24-5/8	2.4	1.8	2.2
BK24-3/4	2.4	1.8	2.2
BK24-7/8	2.4	1.8	2.2
BK25-1/2	2.5	1.9	2.3
BK25-5/8	2.5	1.9	2.3
BK25-3/4	2.5	1.9	2.3
BK25-7/8	2.5	1.9	2.3
BK25-1	2.5	1.9	2.3
BK26-1/2	2.6	2.0	2.4
BK26-5/8	2.6	2.0	2.4
BK26-3/4	2.6	2.0	2.4
BK26-7/8	2.6	2.0	2.4
BK27-1/2	2.7	2.1	2.5
BK27-5/8	2.7	2.1	2.5
BK27-3/4	2.7	2.1	2.5
BK27-7/8	2.7	2.1	2.5
BK27-1	2.7	2.1	2.5
BK28-1/2	2.95	2.2	2.6
BK28-5/8	2.95	2.2	2.6
BK28-3/4	2.95	2.2	2.6
BK28-7/8	2.95	2.2	2.6
BK28-1	2.95	2.2	2.6
BK28-1-1/8	2.95	2.2	2.6
BK30-1/2	3.15	2.4	2.8
BK30-5/8	3.15	2.4	2.8
BK30-3/4	3.15	2.4	2.8
BK30-7/8	3.15	2.4	2.8
BK30-1	3.15	2.4	2.8
BK30-1-1/8	3.15	2.4	2.8
BK32-1/2	3.35	2.6	3.0
BK32-5/8	3.35	2.6	3.0
BK32-3/4	3.35	2.6	3.0
BK32-7/8	3.35	2.6	3.0
BK32-1	3.35	2.6	3.0
BK32-1-1/8	3.35	2.6	3.0
BK34-1/2	3.55	2.8	3.2
BK34-5/8	3.55	2.8	3.2
BK34-3/4	3.55	2.8	3.2
BK34-7/8	3.55	2.8	3.2
BK34-1	3.55	2.8	3.2
BK34-1-1/8	3.55	2.8	3.2

4L/A & 5L/B SECTIONS			
PART NUMBER	OUTSIDE DIAMETER (IN.)	4L & A PITCH DIAMETER (IN.)	5L & B PITCH DIAMETER (IN.)
BK36-1/2	3.75	3.0	3.4
BK36-5/8	3.75	3.0	3.4
BK36-3/4	3.75	3.0	3.4
BK36-7/8	3.75	3.0	3.4
BK36-1	3.75	3.0	3.4
BK36-1-1/8	3.75	3.0	3.4
BK40-1/2	3.95	3.2	3.6
BK40-5/8	3.95	3.2	3.6
BK40-3/4	3.95	3.2	3.6
BK40-7/8	3.95	3.2	3.6
BK40-1	3.95	3.2	3.6
BK40-1-1/8	3.95	3.2	3.6
BK45-1/2	4.25	3.5	3.9
BK45-5/8	4.25	3.5	3.9
BK45-3/4	4.25	3.5	3.9
BK45-7/8	4.25	3.5	3.9
BK45-1	4.25	3.5	3.9
BK45-1-1/8	4.25	3.5	3.9
BK47-1/2	4.45	3.7	4.1
BK47-5/8	4.45	3.7	4.1
BK47-3/4	4.45	3.7	4.1
BK47-7/8	4.45	3.7	4.1
BK47-1	4.45	3.7	4.1
BK47-1-1/8	4.45	3.7	4.1
BK50-1/2	4.75	4.0	4.4
BK50-5/8	4.75	4.0	4.4
BK50-3/4	4.75	4.0	4.4
BK50-7/8	4.75	4.0	4.4
BK50-1	4.75	4.0	4.4
BK50-1-1/8	4.75	4.0	4.4
BK52-1/2	4.95	4.2	4.6
BK52-5/8	4.95	4.2	4.6
BK52-3/4	4.95	4.2	4.6
BK52-7/8	4.95	4.2	4.6
BK52-1	4.95	4.2	4.6
BK52-1-1/8	4.95	4.2	4.6
BK55-1/2	5.25	4.5	4.9
BK55-5/8	5.25	4.5	4.9
BK55-3/4	5.25	4.5	4.9
BK55-7/8	5.25	4.5	4.9
BK55-1	5.25	4.5	4.9
BK55-1-1/8	5.25	4.5	4.9
BK55-1-3/16	5.25	4.5	4.9

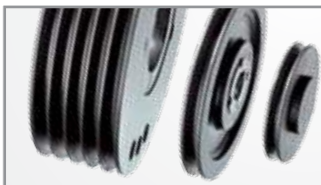

**ADDITIONAL SIZES AVAILABLE.  
CONTACT AN OPTIBELT  
REPRESENTATIVE FOR MORE  
INFORMATION**



# 4L/A & 5L/B SECTIONS

BORE TO SIZE

**optibelt KS**  
BUSHINGS SHEAVES



4L/A & 5L/B SECTIONS			
PART NUMBER	OUTSIDE DIAMETER (IN.)	4L & A PITCH DIAMETER (IN.)	5L & B PITCH DIAMETER (IN.)
BK57-5/8	5.45	4.7	5.1
BK57-3/4	5.45	4.7	5.1
BK57-7/8	5.45	4.7	5.1
BK57-15/16	5.45	4.7	5.1
BK57-1	5.45	4.7	5.1
BK57-1-1/8	5.45	4.7	5.1
BK57-1-3/16	5.45	4.7	5.1
BK60-1/2	5.75	5.0	5.4
BK60-5/8	5.75	5.0	5.4
BK60-3/4	5.75	5.0	5.4
BK60-7/8	5.75	5.0	5.4
BK60-1	5.75	5.0	5.4
BK60-1-1/8	5.75	5.0	5.4
BK60-1-3/16	5.75	5.0	5.4
BK62-1/2	5.95	5.2	5.6
BK62-5/8	5.95	5.2	5.6
BK62-3/4	5.95	5.2	5.6
BK62-7/8	5.95	5.2	5.6
BK62-15/16	5.95	5.2	5.6
BK62-1	5.95	5.2	5.6
BK62-1-1/8	5.95	5.2	5.6
BK62-1-3/16	5.95	5.2	5.6
BK65-5/8	6.25	5.5	5.9
BK65-3/4	6.25	5.5	5.9
BK65-1	6.25	5.5	5.9
BK65-1-1/8	6.25	5.5	5.9
BK67-5/8	6.45	5.7	6.1
BK67-3/4	6.45	5.7	6.1
BK67-1	6.45	5.7	6.1
BK67-1-1/8	6.45	5.7	6.1
BK67-1-3/16	6.45	5.7	6.1
BK70-5/8	6.75	6.0	6.4
BK70-3/4	6.75	6.0	6.4
BK70-15/16	6.75	6.0	6.4
BK70-1	6.75	6.0	6.4
BK70-7/8	6.75	6.0	6.4
BK70-1-1/8	6.75	6.0	6.4
BK70-1-3/16	6.75	6.0	6.4
BK70-1-7/16	6.75	6.0	6.4
BK72-3/4	6.95	6.2	6.6
BK72-1	6.95	6.2	6.6
BK72-1-1/8	6.95	6.2	6.6
BK72-1-3/8	6.95	6.2	6.6

4L/A & 5L/B SECTIONS			
PART NUMBER	OUTSIDE DIAMETER (IN.)	4L & A PITCH DIAMETER (IN.)	5L & B PITCH DIAMETER (IN.)
BK75-3/4	7.25	6.5	6.9
BK75-1	7.25	6.5	6.9
BK75-1-1/8	7.25	6.5	6.9
BK77-3/4	7.45	6.7	7.1
BK77-1	7.45	6.7	7.1
BK77-1-1/8	7.45	6.7	7.1
BK77-1-3/8	7.45	6.7	7.1
BK80-5/8	7.75	7.0	7.4
BK80-3/4	7.75	7.0	7.4
BK80-7/8	7.75	7.0	7.4
BK80-1	7.75	7.0	7.4
BK80-1-1/8	7.75	7.0	7.4
BK80-1-3/16	7.75	7.0	7.4
BK80-1-1/4	7.75	7.0	7.4
BK80-1-3/8	7.75	7.0	7.4
BK80-1-7/16	7.75	7.0	7.4
BK85-3/4	8.25	7.5	7.9
BK85-1	8.25	7.5	7.9
BK85-1-1/8	8.25	7.5	7.9
BK85-1-3/8	8.25	7.5	7.9
BK85-1-7/16	8.25	7.5	7.9
BK90-3/4	8.75	8.0	8.4
BK90-7/8	8.75	8.0	8.4
BK90-15/16	8.75	8.0	8.4
BK90-1	8.75	8.0	8.4
BK90-1-1/8	8.75	8.0	8.4
BK90-1-3/16	8.75	8.0	8.4
BK90-1-3/8	8.75	8.0	8.4
BK90-1-7/16	8.75	8.0	8.4
BK95-3/4	9.25	8.5	8.9
BK95-1	9.25	8.5	8.9
BK95-1-1/8	9.25	8.5	8.9
BK95-1-3/8	9.25	8.5	8.9
BK100-3/4	9.75	9.0	9.4
BK100-7/8	9.75	9.0	9.4
BK100-15/16	9.75	9.0	9.4
BK100-1	9.75	9.0	9.4
BK100-1-1/8	9.75	9.0	9.4
BK100-1-3/16	9.75	9.0	9.4
BK100-1-1/4	9.75	9.0	9.4
BK100-1-3/8	9.75	9.0	9.4
BK100-1-7/16	9.75	9.0	9.4

**KS 4L/A 5L/B**  
SHEAVES & BUSHINGS

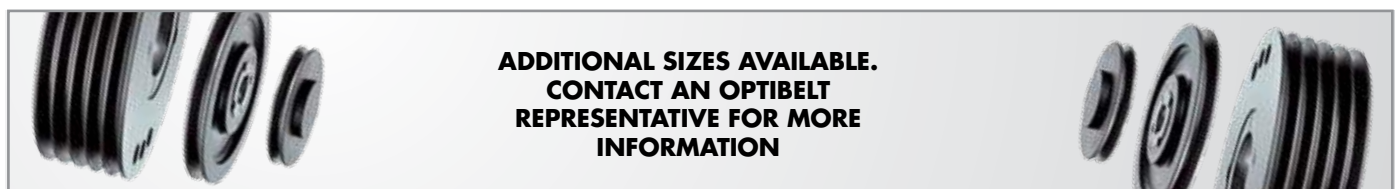



**optibelt KS**  
BUSHING SHEAVES

**4L/A & 5L/B SECTIONS**

BORE TO SIZE

**KS 4L/A 5L/B**  
SHEAVES & BUSHINGS

4L/A & 5L/B SECTIONS			
PART NUMBER	OUTSIDE DIAMETER (IN.)	4L & A PITCH DIAMETER (IN.)	5L & B PITCH DIAMETER (IN.)
BK105-1	10.25	9.5	9.9
BK105-1-3/8	10.25	9.5	9.9
BK105-1-7/16	10.25	9.5	9.9
BK110-3/4	10.75	10.0	10.4
BK110-1	10.75	10.0	10.4
BK110-1-1/8	10.75	10.0	10.4
BK110-1-3/16	10.75	10.0	10.4
BK110-1-3/8	10.75	10.0	10.4
BK110-1-7/16	10.75	10.0	10.4
BK115-1	11.25	10.5	10.9
BK115-1-7/16	11.25	10.5	10.9
BK120-3/4	11.75	11.0	11.4
BK120-1	11.75	11.0	11.4
BK120-1-3/16	11.75	11.0	11.4
BK120-1-7/16	11.75	11.0	11.4
BK130-3/4	12.75	12.0	12.4
BK130-1	12.75	12.0	12.4
BK130-1-1/8	12.75	12.0	12.4
BK130-1-3/16	12.75	12.0	12.4
BK130-1-1/4	12.75	12.0	12.4
BK130-1-7/16	12.75	12.0	12.4

4L/A & 5L/B SECTIONS			
PART NUMBER	OUTSIDE DIAMETER (IN.)	4L & A PITCH DIAMETER (IN.)	5L & B PITCH DIAMETER (IN.)
BK140-3/4	13.75	13.0	13.4
BK140-1	13.75	13.0	13.4
BK140-1-3/16	13.75	13.0	13.4
BK140-1-7/16	13.75	13.0	13.4
BK160-1	15.75	15.0	15.4
BK160-1-1/8	15.75	15.0	15.4
BK160-1-3/16	15.75	15.0	15.4
BK160-1-1/4	15.75	15.0	15.4
BK160-1-7/16	15.75	15.0	15.4
BK190-1	18.75	18.0	18.4
BK190-1-3/16	18.75	18.0	18.4
BK190-1-1/4	18.75	18.0	18.4
BK190-1-7/16	18.75	18.0	18.4

STANDARD KEY DIMENSIONS	
SHAFT DIAMETER	KEYSEAT (WIDTH X DEPTH)
1/2	None
5/8-7/8	3/16 x 3/32
15/16-1 1/4	1/4 x 1/8
1-5/16-1 3/8	5/16 x 5/32
1-7/16-1 3/4	3/8 x 3/16

**ADDITIONAL SIZES AVAILABLE.  
CONTACT AN OPTIBELT  
REPRESENTATIVE FOR MORE  
INFORMATION**



# 4L/A & 5L/B SECTIONS

BORE TO SIZE

**optibelt KS**  
BUSHING SHEAVES



4L/A & 5L/B SECTIONS (2 SHEAVE)			
PART NUMBER	OUTSIDE DIAMETER (IN.)	4L/A PITCH DIAMETER (IN.)	5L/B PITCH DIAMETER (IN.)
2BK25-1/2	2.5	1.9	2.3
2BK25-5/8	2.5	1.9	2.3
2BK25-3/4	2.5	1.9	2.3
2BK25-7/8	2.5	1.9	2.3
2BK27-1/2	2.7	2.1	2.5
2BK27-5/8	2.7	2.1	2.5
2BK27-3/4	2.7	2.1	2.5
2BK27-7/8	2.7	2.1	2.5
2BK27-1	2.7	2.1	2.5
2BK27-1-1/8	2.7	2.1	2.5
2BK28-1/2	2.95	2.2	2.6
2BK28-5/8	2.95	2.2	2.6
2BK28-3/4	2.95	2.2	2.6
2BK28-7/8	2.95	2.2	2.6
2BK28-1	2.95	2.2	2.6
2BK28-1-1/8	2.95	2.2	2.6
2BK30-1/2	3.15	2.4	2.8
2BK30-5/8	3.15	2.4	2.8
2BK30-3/4	3.15	2.4	2.8
2BK30-7/8	3.15	2.4	2.8
2BK30-1	3.15	2.4	2.8
2BK30-1-1/8	3.15	2.4	2.8
2BK30-1-3/8	3.15	2.4	2.8
2BK32-1/2	3.35	2.6	3.0
2BK32-5/8	3.35	2.6	3.0
2BK32-3/4	3.35	2.6	3.0
2BK32-7/8	3.35	2.6	3.0
2BK32-1	3.35	2.6	3.0
2BK32-1-1/8	3.35	2.6	3.0
2BK34-5/8	3.55	2.8	3.2
2BK34-3/4	3.55	2.8	3.2
2BK34-7/8	3.55	2.8	3.2
2BK34-1	3.55	2.8	3.2
2BK34-1-1/8	3.55	2.8	3.2
2BK36-5/8	3.75	3.0	3.4
2BK36-3/4	3.75	3.0	3.4
2BK36-7/8	3.75	3.0	3.4
2BK36-1	3.75	3.0	3.4
2BK36-1-1/8	3.75	3.0	3.4
2BK36-1-3/8	3.75	3.0	3.4

4L/A & 5L/B SECTIONS (2 SHEAVE)			
PART NUMBER	OUTSIDE DIAMETER (IN.)	4L & A PITCH DIAMETER (IN.)	5L & B PITCH DIAMETER (IN.)
2BK40-5/8	3.95	3.2	3.6
2BK40-3/4	3.95	3.2	3.6
2BK40-7/8	3.95	3.2	3.6
2BK40-1	3.95	3.2	3.6
2BK40-1-1/8	3.95	3.2	3.6
2BK45-1	4.25	3.5	3.9
2BK45-1-1/8	4.25	3.5	3.9
2BK45-1-3/8	4.25	3.5	3.9
2BK47-7/8	4.75	4.0	4.4
2BK47-1	4.75	4.0	4.4
2BK47-1-1/8	4.75	4.0	4.4
2BK47-1-3/8	4.75	4.0	4.4
2BK50-3/4	4.95	4.2	4.6
2BK50-1	4.95	4.2	4.6
2BK50-1-1/8	4.95	4.2	4.6
2BK50-1-3/8	4.95	4.2	4.6
2BK52-5/8	5.25	4.5	4.9
2BK52-7/8	5.25	4.5	4.9
2BK52-1	5.25	4.5	4.9
2BK52-1-1/8	5.25	4.5	4.9
2BK52-1-3/8	5.25	4.5	4.9
2BK55-1-1/8	5.45	4.7	5.1
2BK55-1-3/8	5.45	4.7	5.1
2BK57-1	5.75	5.0	5.4
2BK57-1-1/8	5.75	5.0	5.4
2BK57-1-3/8	5.75	5.0	5.4
2BK60-3/4	5.95	5.2	5.6
2BK60-7/8	5.95	5.2	5.6
2BK60-1	5.95	5.2	5.6
2BK60-1-1/8	5.95	5.2	5.6
2BK60-1-3/8	5.95	5.2	5.6
2BK62-1	6.25	5.5	5.9
2BK62-1-1/8	6.25	5.5	5.9
2BK65-1	6.25	5.5	5.9
2BK65-1-1/8	6.25	5.5	5.9
2BK56-1-3/8	6.25	5.5	5.9

KS 4L/A 5L/B SHEAVES & BUSHINGS

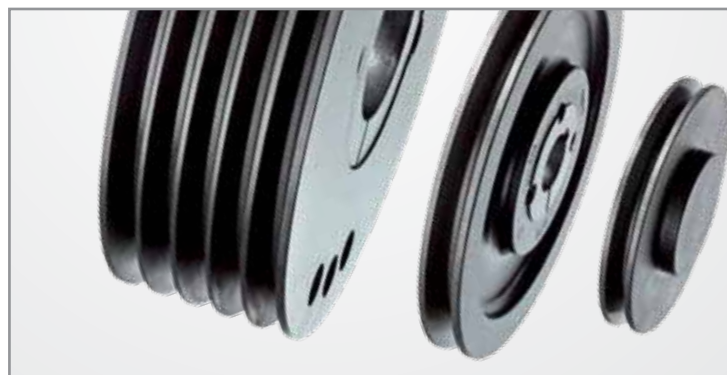

**ADDITIONAL SIZES AVAILABLE.  
CONTACT AN OPTIBELT  
REPRESENTATIVE FOR MORE  
INFORMATION**



**optibelt KS**  
BUSHING SHEAVES

**4L/A & 5L/B SECTIONS**

BORE TO SIZE

**KS 4L/A 5L/B**  
SHEAVES & BUSHINGS

4L/A & 5L/B SECTIONS			
PART NUMBER	OUTSIDE DIAMETER (IN.)	4L & A PITCH DIAMETER (IN.)	5L & B PITCH DIAMETER (IN.)
2BK67-1	6.45	5.7	6.1
2BK67-1-1/8	6.45	5.7	6.1
2BK67-1-3/8	6.45	5.7	6.1
2BK70-3/4	6.75	6.0	6.4
2BK70-1	6.75	6.0	6.4
2BK70-1-1/8	6.75	6.0	6.4
2BK70-1-3/8	6.75	6.0	6.4
2BK70-1-7/16	6.75	6.0	6.4
2BK80-3/4	7.75	7.0	7.4
2BK80-1	7.75	7.0	7.4
2BK80-1-1/8	7.75	7.0	7.4
2BK80-1-3/16	7.75	7.0	7.4
2BK80-1-3/8	7.75	7.0	7.4
2BK80-1-7/16	7.75	7.0	7.4
2BK90-3/4	8.75	8.0	8.4
2BK90-1	8.75	8.0	8.4
2BK90-1-1/8	8.75	8.0	8.4
2BK90-1-3/16	8.75	8.0	8.4
2BK90-1-3/8	8.75	8.0	8.4
2BK90-1-7/16	8.75	8.0	8.4
BK100-3/4	9.75	9.0	9.4
BK100-1	9.75	9.0	9.4
BK100-1-3/16	9.75	9.0	9.4
BK100-1-3/8	9.75	9.0	9.4
BK100-1-7/16	9.75	9.0	9.4

4L/A & 5L/B SECTIONS			
PART NUMBER	OUTSIDE DIAMETER (IN.)	4L & A PITCH DIAMETER (IN.)	5L & B PITCH DIAMETER (IN.)
BK110-1	10.75	10.0	10.4
BK110-1-3/16	10.75	10.0	10.4
BK110-1-7/16	10.75	10.0	10.4
BK120-1	11.75	11.0	11.4
BK120-1-3/16	11.75	11.0	11.4
BK120-1-7/16	11.75	11.0	11.4
BK130-1	12.75	12.0	12.4
BK130-1-3/16	12.75	12.0	12.4
BK130-1-7/16	12.75	12.0	12.4
BK140-1	13.75	13.0	13.4
BK140-1-3/16	13.75	13.0	13.4
BK140-1-7/16	13.75	13.0	13.4
BK160-1	15.75	15.0	15.4
BK160-1-3/16	15.75	15.0	15.4
BK160-1-7/16	15.75	15.0	15.4
BK190-1-3/16	18.75	18.0	18.4
BK190-1-1/4	18.75	18.0	18.4
BK190-1-7/16	18.75	18.0	18.4

STANDARD KEY DIMENSIONS	
SHAFT DIAMETER	KEYSEAT (WIDTH X DEPTH)
1/2	None
5/8-7/8	3/16 x 3/32
15/16-1 1/4	1/4 x 1/8
1-5/16-1 3/8	5/16 x 5/32
1-7/16-1 3/4	3/8 x 3/16

**ADDITIONAL SIZES AVAILABLE.  
CONTACT AN OPTIBELT  
REPRESENTATIVE FOR MORE  
INFORMATION**







TAPER LOCK BUSHING WITH METRIC BORES. KEYWAYS TO DIN 6885 PART 1																	
	TAPER BUSH																
	MATERIAL: GG 20 – DIN 1961																
	1008	1108	1210	1215	1310	1610	1615	2012	2517	3020	3030	3525	3535	4040	4545	5050	
BORE SIZE d <sub>2</sub> (MM)	10	10	11	11	14	14	14	14	16	25	35	35	35	40	55	70	
	11	11	12	12	16	16	16	16	18	28	38	38	38	42	60	75	
	12	12	14	14	18	18	18	18	19	30	40	40	40	45	65	80	
	14	14	16	16	19	19	19	19	20	32	42	42	42	48	70	85	
	16	16	18	18	20	20	20	20	22	35	45	45	45	50	75	90	
	18	18	19	19	22	22	22	22	24	38	48	48	48	55	80	95	
	19	19	20	20	24	24	24	24	25	40	50	50	50	60	85	100	
	20	20	22	22	25	25	25	25	28	42	55	55	55	65	90	105	
	22	22	24	24	28	28	28	28	30	45	60	60	60	70	95	110	
	24•	24	25	25	30	30	30	30	32	48	65	65	65	75	100	115	
	25•	25	28	28	32	32	32	32	35	50	70	70	70	80	105	120	
			28	30	30	35	35	35	35	38	55	75	75	75	85	110	125
				32	32		38	38	38	40	60		80	80	90		
							40	40	40	42	65		85	85	95		
							42•	42•	42	45	70		90	90	100		
									45	48	75						
								48	50								
								50	55								
									60								
TIGHTENING TORQUE (Nm)	5.7	5.7	20	20	20	20	20	31	49	92	92	115	115	172	195	275	
BUSH LENGTH (MM)	22.3	22.3	25.4	38.1	25.4	25.4	38.1	31.8	44.5	50.8	76.2	63.5	88.9	101.6	114.3	127.0	
WEIGHT AT d <sub>2</sub> MIN (≈ KG)	0.12	0.16	0.28	0.39	0.32	0.41	0.60	0.75	1.06	2.50	3.75	3.90	5.13	7.68	12.70	15.17	

TAPER LOCK BUSHING WITH INCH BORES. KEYWAYS TO BS 46 PART 1																	
	TAPER BUSH																
	MATERIAL: GG 20 – DIN 1961																
	1008	1108	1210	1215	1310	1610	1615	2012	2517	3020	3030	3525	3535	4040	4545	5050	
BORE SIZE d <sub>2</sub> (IN)	3/8*	3/8*	1/2	5/8*	1/2*	1/2	1/2	5/8*	3/4	1-1/4	1-1/4	1-1/2*	1-1/2	1-3/4*	2-1/4*	3*	
	1/2	1/2	5/8	3/4	5/8*	5/8	5/8	3/4	7/8	1-3/8	1-3/8	1-5/8*	1-5/8	1-7/8*	2-3/8*	3-1/4*	
	5/8	5/8	3/4	7/8	3/4*	3/4	3/4	7/8	1	1-1/2	1-1/2	1-3/4*	1-3/4	2*	2-1/2*	3-1/2*	
	3/4	3/4	7/8	1	7/8*	7/8	7/8	1	1-1/8	1-5/8	1-5/8	1-7/8*	1-7/8	2-1/8*	2-3/4*	3-3/4*	
	7/8*	7/8	1	1-1/8	1*	1	1	1-1/8	1-1/4	1-3/4*	1-3/4*	2*	2	2-1/4*	2-7/8*	4*	
	1•	1	1-1/8	1-1/4	1-1/8	1-1/8	1-1/8	1-1/4	1-3/8	1-7/8	1-7/8	2-1/8*	2-1/8	2-3/8*	3*	4-1/4*	
			1-1/8•*	1-1/4		1-1/4	1-1/4	1-1/4	1-3/8	1-1/2	2	2	2-1/4*	2-1/4	2-1/2*	3-1/4*	4-1/2*
						1-3/8	1-3/8	1-3/8	1-1/2	1-5/8	2-1/8*	2-1/8*	2-3/8*	2-3/8	2-5/8*	3-3/8*	4-3/4*
							1-1/2	1-1/2	1-5/8	1-3/4	2-1/4	2-1/4	2-1/2*	2-1/2	2-3/4*	3-1/2*	5•*
							1-5/8	1-5/8	1-3/4	1-7/8	2-3/8	2-3/8	2-5/8*	2-5/8	2-7/8*	3-3/4*	
									1-7/8	2	2-1/2	2-1/2	2-3/4*	2-3/4	3*	4*	
									2	2-1/8	2-5/8	2-5/8*	2-7/8*	2-7/8	3-1/8*	4-1/4•*	
										2-1/4	2-3/4	2-3/4*	3*	3	3-1/4*	4-1/2•*	
										2-3/8	2-7/8	2-7/8	3-1/8*	3-1/8	3-3/8*		
										2-1/2	3	3	3-1/4*	3-1/4	3-1/2*		
													3-3/8*	3-3/8	3-3/4*		
												3-1/2•*	3-1/2•	4•*			
TIGHTENING TORQUE (Nm)	5.7	5.7	20	20	20	20	20	31	49	92	92	115	115	172	195	275	
BUSH LENGTH (MM)	22.3	22.3	25.4	38.1	25.4	25.4	38.1	31.8	44.5	50.8	76.2	63.5	88.9	101.6	114.3	127.0	
WEIGHT AT d <sub>2</sub> MIN (≈ KG)	0.12	0.16	0.28	0.39	0.32	0.41	0.60	0.75	1.06	2.50	3.75	3.90	5.13	7.68	12.70	15.17	

\*NON-STOCK ITEM      •SHALLOW KEYWAY

TB BUSHINGS  
SHEAVES & BUSHINGS



**KEYSEAT DIMENSIONS TO NEMA STANDARDS UNLESS MARKED WITH \***

PART NUMBER	JA	SH	SDS	SD	SK	SF	E	F	J	M	N
BORE DIAMETER (INCH)	7/16	1/2	1/2	1/2	1/2	1/2	7/8	1	1-7/16	1-15/16	2-15/16
	1/2	9/16	9/16	9/16	9/16	9/16	15/16	1-1/16	1-1/2	2	2-15/16
	9/16	5/8	5/8	5/8	5/8	5/8	1	1-1/4	1-9/16	2-1/6	3
	5/8	11/16	11/16	11/16	11/16	11/16	1-1/16	1-1/8	1-5/8	2-1/8	3-1/8
	11/16	3/4	3/4	3/4	3/4	3/4	1-1/4	1 1/4	1-11/16	2-3/16	3-3/16
	3/4	13/16	13/16	13/16	13/16	13/16	1-1/8	1-5/16	1-3/4	2-1/4	3-1/4
	13/16	7/8	7/8	7/8	7/8	7/8	1-1/4	1-3/8	1-13/16	2-5/16	3-5/16
	7/8	15/16	15/16	15/16	15/16	15/16	1-5/16	1-7/16	1-7/8	2-3/8	3-1/4
	15/16	1	1	1	1	1	1-3/8	1-1/2	1-15/16	2-7/16	3-5/16
	1	1-1/16	1-1/16	1-1/16	1-1/16	1-1/16	1-7/16	1-9/16	2	2-1/2	3-3/8
	1-1/16	1-1/4	1-1/4	1-1/4	1-1/4	1-1/4	1-1/2	1-5/8	2-1/6	2-9/16	3-7/16
	1-1/4*	1-1/8	1-1/8	1-1/8	1-1/8	1-1/8	1-9/16	1-11/16	2-1/8	2-5/8	3-1/2
	1-1/8*	1-1/4	1-1/4	1-1/4	1-1/4	1-1/4	1-5/8	1-3/4	2-3/16	2-11/16	3-5/8
	1-1/4*	1-5/16	1-5/16	1-5/16	1-5/16	1-5/16	1-11/16	1-13/16	2-1/4	2-3/4	3-11/16
		1-3/8	1-3/8	1-3/8	1-3/8	1-3/8	1-3/4	1-7/8	2-5/16	2-13/16	3-3/4
		1-7/16*	1-7/16	1-7/16	1-7/16	1-7/16	1-13/16	1-15/16	2-3/8	2-7/8	3-13/16
		1-1/2*	1-1/2	1-1/2	1-1/2	1-1/2	1-7/8	2	2-7/16	2-15/16	3-7/8
		1-9/16*	1-9/16	1-9/16	1-9/16	1-9/16	1-15/16	2-1/6	2-1/2	2-15/16	3-15/16
		1-5/8*	1-5/8	1-5/8	1-5/8	1-5/8	2	2-1/8	2-9/16	3	4
		1-11/16*	1-11/16	1-11/16	1-11/16	1-11/16	2-1/6	2-3/16	2-5/8	3-1/8	4-1/8
			1-3/4*	1-3/4*	1-3/4	1-3/4	2-1/8	2-1/4	2-11/16	3-3/16	4-3/16
			1-13/16*	1-13/16*	1-13/16	1-13/16	2-3/16	2-5/16	2-3/4	3-1/4	4-1/4
			1-7/8*	1-7/8*	1-7/8	1-7/8	2-1/4	2-3/8	2-13/16	3-5/16	4-3/8
			1-15/16*	1-15/16*	1-15/16	1-15/16	2-5/16	2-7/16	2-7/8	3-1/4	4-7/16
			2*	2*	2	2	2-3/8	2-1/2	2-15/16	3-5/16	4-1/2
					2 1/6	2 1/6	2-7/16	2 9/16	2-15/16	3-3/8	4-5/8
					2 1/8	2 1/8	2-1/2	2-5/8	3	3-7/16	4-1/16
					2 3/16*	2 3/16	2-9/16	2-11/16	3-1/8	3-1/2	4-3/4
					2 1/4*	2 1/4*	2-5/8	2-3/4	3-3/16	3-5/8	4-7/8
					2 5/16*	2 5/16*	2-11/16	2-13/16	3-1/4	3-11/16	4-15/16
					2 3/8*	2 3/8*	2-3/4	2-7/8	3-5/16	3-3/4	5
					2 7/16*	2 7/16*	2-13/16*	2-15/16	3-1/4	3-13/16	5-3/16*
				2 1/2*	2 1/2*	2-7/8*	2-15/16	3-5/16	3-7/8	5-7/16*	
				2 9/16*	2 9/16*	2-15/16*	3	3-3/8	3-15/16	5-1/2*	
				2 5/8*	2 5/8*	2-15/16*	3-1/8	3-7/16	4		
						2 11/16*	3*	3-3/16	3-1/2	4-1/8	
						2 3/4*	3-1/8*	3-1/4	3-5/8	4-3/16	
						2 13/16*	3-3/16*	3-5/16*	3-11/16	4-1/4	
						2 7/8*	3-1/4*	3-1/4*	3-3/4	4-3/8	
						2 15/16*	3-5/16*	3-5/16*	3-13/16*	4-7/16	
							3-1/4*	3-3/8*	3-7/8*	4-1/2	
							3-5/16*	3-7/16*	3-15/16*	4-5/8	
							3-3/8*	3-1/2*	4*	4-1/16	
							3-7/16*	3-5/8*	4-1/8*	4-3/4	
							3-1/2*	3-11/16*	4-3/16*	4-7/8*	
								3-3/4*	4-1/4*	4-15/16*	
								3-7/8*	4-3/8*	5*	
								3-15/16*	4-7/16*	5-3/16*	
								4*	4-1/2*	5-1/4*	
										5-3/8*	
										5-7/16*	
										5-1/2*	

\* SHALLOW KEY/KEYSTOCK SUPPLIED WITH BUSHING

• NO KEY

**QD BUSHINGS**  
SHEAVES & BUSHINGS



KEYWAY DIMENSIONS TO DIN 6885 PART 1											
PART NUMBER	JA	SH	SDS	SD	SK	SF	E	F	J	M	N
BORE DIAMETER (MM) (d <sub>2</sub> )	15	15	24	24	14	28	35	42	50	80	100
	16	20	25	25	20	30	38	45	55	90	120
	19	22	28	28	24	32	40	48	60	100	
	20	24	30	30	25	35	42	50	65	120	
	22	25	32	32	28	38	45	55	70		
	24	30	35	35	30	40	48	60	75		
	25	32	38	38	32	42	50	65	80		
	28	35	40	40	35	45	55	70	85		
		38	42	42	38	48	60	75	90		
					40	50	65	80	95		
					42	55	70	85	100		
					45	60	75	90			
					48	65	80				
					50						
					55						
				60							

**QD BUSHINGS**  
SHEAVES & BUSHINGS

**ADDITIONAL SIZES AVAILABLE.  
CONTACT AN OPTIBELT  
REPRESENTATIVE FOR MORE  
INFORMATION**



## optibelt SERVICE KIT

Includes all that is needed to keep belts tensioned properly, drives aligned and notes are easily referenced.

### INCLUDES:

- Service Kit
- TT Optical Frequency Tension Tester
- Laser Pointer II Drive Alignment
- Label Kit
- Carrying Case



## optibelt TT-OPTICAL

### LED TENSION TESTER

Measures ranges 5 – 500 Hz.  
Includes carry case.

### ADVANTAGES

- Impervious to machine or background noise
- Wide measuring range from 5-500 Hz
- Highly accurate



## optibelt TT MINI S

### FREQUENCY TENSION TESTER

Frequency measures belt tension from 10 – 600 Hz. with flexible goose neck.  
Includes carry case.

### ADVANTAGES

- Wide measuring range from 10-600 Hz
- Flexible goose-neck
- Easier to carry
- Highly accurate



## optibelt OPTIKRIK 0, 1, 2, 3 TENSION TESTERS

Belt tension gauges reliably check whether a V, ribbed, or banded belt has been correctly tensioned.

### Tension Gauges:

- Optikrik 0 Range: 15 – 35 lbs
- Optikrik I Range: 30 – 150 lbs
- Optikrik II Range: 100 – 300 lbs
- Optikrik III Range: 300 – 700 lbs



## optibelt SERVICE BOX

An all-in-one simple service box contains all you need to tension belts, measure sheaves, and measure drive or belt lengths.

### CONTENTS

- 4 pieces Optikrik gauges, Types 0, I, II, III
- 1 set of V-belt and pulley groove gauges
- 1 measuring tape, 10 ft
- 1 ballpoint pen
- 1 set of ribbed belt groove gauges



## optibelt LASER POINTER II DRIVE ALIGNMENT

Allows for precision alignment of belt drives. Magnetic measurement points and laser makes the process quick and easy.

### CONTENTS

- Magnetic laser pointer
- 5 Magnetic alignment measuring guides
- Magnetic leveling bar





# TECHNICAL TOOLS MAINTENANCE

## BELT LENGTH GAUGE

Accurately measures V-belts  
from 500 – 2500 mm  
(19.5 – 98.5 in)  
inside length (Li).



## V-BELT & RIBBED GAUGES

Valuable tools for measuring v-belt and  
ribbed belt sheaves to ensure proper fit.

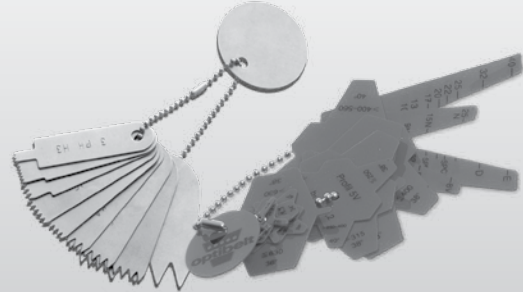

## optibelt CAP DRIVE CALCULATION SOFTWARE

Download the free and current version of our  
drive & length calculation software for V,  
ribbed & timing belts to optimize drive  
performance. Available at: [www.optibelt-usa.com](http://www.optibelt-usa.com)

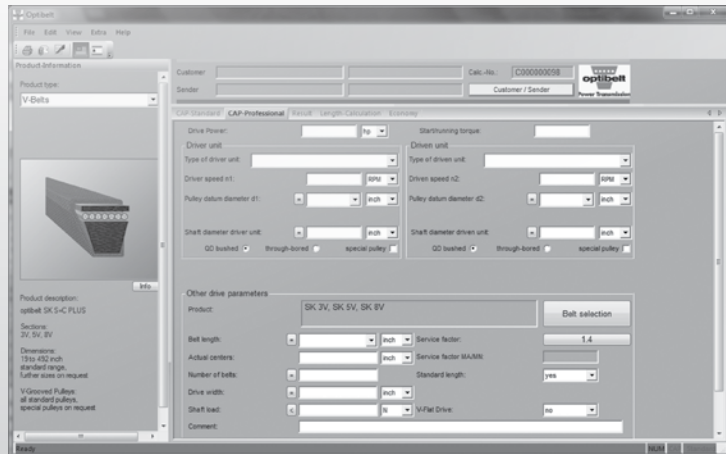

TECH TOOLS  
MAINTENANCE



This simplified tensioning method should be used for installation and maintenance tensioning of the belt when the important technical data is unavailable and the optimum tension cannot be calculated. This method requires only knowledge of the small pulley diameter and the belt section and construction. The gauges themselves may be used to set tensions also when the technical data is known and the optimum tension can be calculated.

## TENSIONING GAUGES – INSTRUCTIONS FOR USE

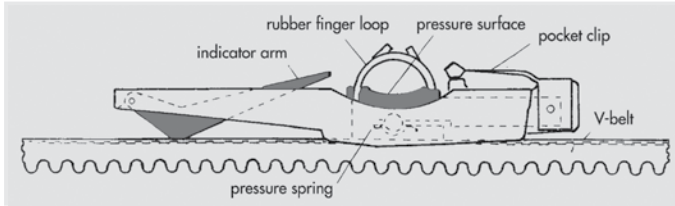

1. Select the gauge appropriate to the belt section and construction being tensioned. See notes below the simplified tensioning table.
2. Figure 2 shows three ways to hold the gauges so that pressure is applied to the black pad only.
3. Position the gauge on one of the belts on the drive in the middle of an accessible span length. Take care to ensure that the gauge is only in contact with one of the belts, and that the indicator is pushed down into the gauge body. Align the gauge so that its body is parallel with the sides of the belt.
4. Push slowly and firmly on the black pad. When a CLICK is heard and/or felt, stop immediately and remove the gauge carefully to avoid disturbing the indicator arm.

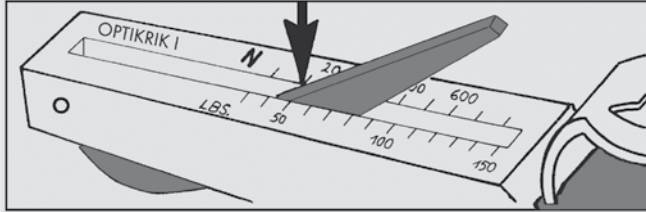

5. Read the gauge to judge the tension as follows.
6. Turn the gauge sideways to ascertain the exact point where the top surface of the black indicator crosses the scale.
7. Mark this point mentally or with a thumbnail and turn the gauge to read the scale.
8. Check the tension found against the simplified tensioning table. Tighten or slacken the belt, if necessary.

### Simplified Tensioning Table

To use this table belt construction (standard wrapped or S-TX raw edge, molded cogged), and the diameter of the smallest pulley on the drive should be known. Note also that the belt tension is higher or lower depending on whether the belt is on first installation or whether it is being re-tensioned.

#### Example

- |                                          |        |
|------------------------------------------|--------|
| 1. V-Belt section                        | 3V     |
| 2. Smallest pulley diameter on drive     | 3.15"  |
| 3. Static tension – initial installation | 55 lbs |
| 4. Static tension – re-tension           | 45 lbs |

BELT SECTION	DIAMETER OF THE SMALLEST PULLEY (INCH)	STATIC TENSION (LBS)			
		STANDARD (WRAPPED)		SUPER X-POWER M=5 SUPER TX M=5	
		INSTALL TENSION	RE-TENSION	INSTALL TENSION	RE-TENSION
<b>SPZ</b>	≤ 2.80	45	35	55	45
<b>3V</b>	> 2.80 ≤ 3.65	55	45	70	55
<b>XPZ</b>	> 3.65 ≤ 5.00	80	55	90	70
<b>3VX</b>	> 5.00 *				
<b>SPA</b>	≤ 3.95	80	55	90	70
<b>XPA</b>	> 3.95 ≤ 5.50	90	70	110	90
	> 5.50 ≤ 8.00	110	90	135	100
	> 8.00 *				
<b>SPB</b>	≤ 6.30	150	110	160	120
<b>5V</b>	> 6.30 ≤ 9.00	160	120	190	150
<b>XPB</b>	> 9.00 ≤ 14.00	200	160	220	180
<b>5VX</b>	> 14.00 *				
<b>SPC</b>	≤ 9.75	220	180	310	250
<b>XPC</b>	> 9.75 ≤ 14.00	310	250	360	270
	> 14.00 ≤ 21.20	400	310	450	350
	> 21.20 *				
<b>Z/10</b>	≤ 2.20	20	15	25	20
<b>ZX/X10</b>	> 2.20 ≤ 2.80	25	20	30	25
	> 2.80 ≤ 3.95	30	25	35	30
	> 3.95 *				
<b>A/13</b>	≤ 3.15	35	25	45	35
<b>AX/X13</b>	> 3.15 ≤ 4.12	45	35	55	45
	> 4.12 ≤ 5.20	70	55	90	70
	> 5.20 *				
<b>B/17</b>	≤ 4.90	70	55	100	80
<b>BX/X17</b>	> 4.90 ≤ 6.30	90	70	110	90
	> 6.30 ≤ 8.00	110	90	135	100
	> 8.00 *				
<b>C/22</b>	≤ 8.00	160	110	180	140
<b>CX/X22</b>	> 8.00 ≤ 9.75	180	140	200	160
	> 9.75 ≤ 14.00	200	160	220	180
	> 14.00 *				

\* Tension values for these sheaves must be calculated.

#### Tension gauges:

Optikrik 0	Range: 15 – 35 lbs
Optikrik I	Range: 30 – 150 lbs
Optikrik II	Range: 100 – 300 lbs
Optikrik III	Range: 300 – 700 lbs

The static tension values shown are calculated for maximum power transmission capability per belt and should be applied only when accurate drive data is not available.

#### Calculation Limitations

Wedge belts	belt speed v = 985 to 8265 feet/min
Classical belts	belt speed v = 985 to 5905 feet/min



# INSTALLATION & STORAGE

## MAINTENANCE

Correct design of drives using V-Belts ensures long belt life and a high degree of operating safety. Premature failure can often be traced back to faulty installation or maintenance, thus the following recommendations are very important.

### SAFETY

Before beginning any maintenance it is extremely important that any and all drive motors and other drive components are completely turned off. Care should be taken that these cannot be switched on again while work is taking place. This will ensure the safety of the maintenance workers.

### SHEAVES

The grooves should be in good condition, free from scores or sharp edges, and all dimensions should conform to the relevant standard.

### ALIGNMENT

Shafts and sheaves should be correctly aligned prior to belt installation. We recommend a maximum tolerance of  $\pm 1/2^\circ$  in both planes.

### MULTIPLE V-BELT DRIVES

For multiple V-Belt drives it is necessary to assemble the belts in matched sets either by measurement or by examination of the manufacturer's code numbers or other markings. It may also be necessary to re-measure the belts if they have been stored for any length of time. V-Belts in S=C PLUS and SUPER TX M=S construction may be used in matched sets without the need for reference to code marks, measurement, or re-measurement after storage.

### INSTALLATION OF THE V-BELTS

The drive center distance should be reduced prior to the installation of the belts so that they may be fitted without undue force. The severe stresses placed upon V-Belts if they are forced over the pulley flanges can damage the cover fabric and the high quality, low stretch tension members.

### BELT TENSIONING

The drive should be tensioned (see initial installation) correctly and re-tensioned (see re-tension) after between 30 minutes and 4 hours at full load, to compensate for the small initial belt stretch and "bedding" into the pulley grooves.

### IDLER PULLEYS

Where possible the use of idler pulleys should be avoided. If for design reasons, such an arrangement is necessary, then an inside idler should be used in preference to an outside idler. For other details refer to our Technical Manual.

### MAINTENANCE

It is recommended that V-Belt drives should be regularly inspected for loss of belt tension, unusual heat build up or wear. Re-tension or replace when necessary.

Should an individual belt in a matched set require replacement for any reason, a complete new set must be fitted.

Belts from different manufacturers must not be mixed on the same drive.

V-Belts need no special attention. Belt dressings must not be used.

### SUMMARY

Properly stored V-Belts ensures the belts integrity will not change over a period of many years (see also DIN 7716). In poor storage conditions and with incorrect handling, rubber products are, however, subject to changes in their integrity. These changes can for example, be caused by the effects of oxygen, ozone, temperature, light, moisture and solvents.

### STORAGE AREA

The storage area should be dry, dust free and reasonably well ventilated.

V-Belts must not be stored close to chemicals, solvents, fuels, lubricants and acids etc.

### TEMPERATURE

The storage temperature should be between  $+15^\circ\text{C}/+59^\circ\text{F}$  and  $+25^\circ\text{C}/+77^\circ\text{F}$ . Normally lower temperatures are not detrimental to V-Belts. Since they become very stiff at low temperatures, before fitting they should be warmed to a temperature of approximately  $+20^\circ\text{C}/+68^\circ\text{F}$  to avoid ruptures and cracks. Radiators and their supply lines should be guarded. The distance between a radiator and the stored V-Belts must be at least three feet.

### LIGHT

V-Belts should be protected against light, especially direct sunlight and high intensity artificial light having a high ultra violet content (ozone formation) such as naked fluorescent tubes. Illumination utilizing conventional light bulbs is advisable.

Wherever possible windows should be painted with a red or orange protective paint. Under no circumstances should blue be used.

### OZONE

In order to counteract the harmful effects of ozone, warehouses should not contain any ozone producing appliances, for example fluorescent lights, mercury vapor lights or high voltage electrical equipment. Combustion gases and vapors which may lead to the formation of ozone by photo chemical processes must be avoided or eliminated.

### MOISTURE

Damp store rooms are unsuitable. Care must be taken to ensure that condensation does not occur. The most favorable relative air humidity is below 65%.

### STORAGE

Storage/stacking stresses can promote permanent deformation and the formation of cracks. Care must be taken to ensure that V-Belts are stored without stress.

If V-Belts are stored horizontally and stacked upon each other, it is recommended that the stack height does not exceed 12 inches to avoid deformation. If, to save space, V-Belts are hung, the diameter of the cylinder on which the belts rest should be at least ten times the height of the belt section.

S=C PLUS and Super X-POWER M=S (SUPER TX) belts do not have to be stored in sets or re-measured before sale.



### CLEANING

Contaminated V-Belts can be cleaned using a 10:1 glycerine-spirit mixture. Benzene, benzol, and turpentine amongst others must not be used.

In addition, sharp edged objects, wire brushes, emery paper etc. must not be used under any circumstances; such action is damaging.



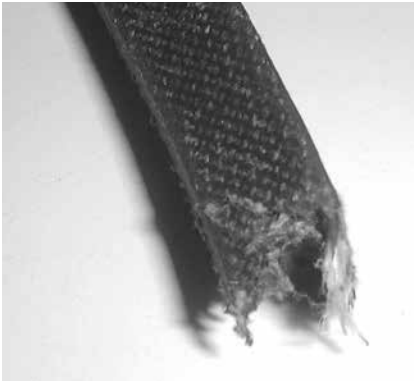

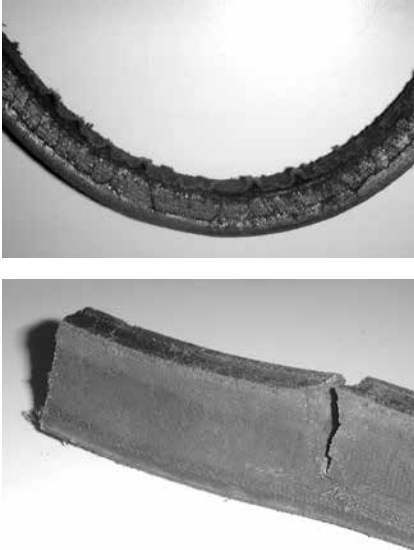

PROBLEM	POSSIBLE CAUSES	SOLUTION
<p><b>Belt breaks after short running period (belt torn)</b></p> 	<p>Forceful mounting, therefore, damaging the tension cord                      Drive blocked                      Ingress of foreign matter during operation                      Drive under-dimensioned, insufficient number of belts</p>	<p>Apply unforced mounting according to instructions                      Remove the cause                      Fit a guard                      Check drive conditions and re-machine</p>
<p><b>Excessive wear on belt edges</b></p> 	<p>Tension too low                      Starting torque too high                      Worn pulley grooves                      Wrong belt/groove section                      Wrong groove angle                      Sheaves do not align                      Small pulley diameter below recommended minimum</p> <p>Belt slips or catches on protruding parts</p>	<p>Check tension and re-tension                      Check drive conditions and re-machine                      Replace sheaves                      Adjust belt and groove sections                      Re-machine or replace sheaves                      Align sheaves                      Increase pulley diameter (new drive design), use OPTIBELT special execution or Super X-POWER M=S (SUPER TX)</p> <p>Remove protrusions or realign drive</p>
<p><b>Cuts and splits at the base of the belt (brittleness)</b></p> 	<p>Outside idler pulley in use the arrangement and diameter of which does not comply with our recommendations</p> <p>Abnormal belt slip</p> <p>Pulley diameter too small</p> <p>Ambient temperature too high</p> <p>Ambient temperature too low</p> <p>Chemical influences</p>	<p>Note OPTIBELT recommendations e. g. increase diameter. Increase size of existing idler. Use RED POWER or OPTIBELT special execution.</p> <p>Re-tension drive according to installation instructions. Check drive conditions and redesign, if necessary. Redesign using minimum pulley diameters.</p> <p>Use OPTIBELT special execution or Super X-POWER M=S (SUPER TX)</p> <p>Ensure good ventilation, protect belts from direct heat. Use XHR special execution (extra heat resistant) or use Super X-POWER M=S(SUPER TX) or belt with aramid cord construction.</p> <p>Warm area surrounding drive and belt before use. Use OPTIBELT special execution.</p> <p>Protect drive from contamination. Use OPTIBELT special execution.</p>

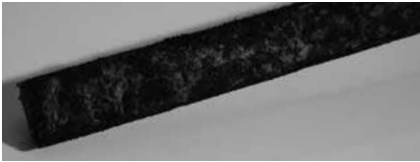
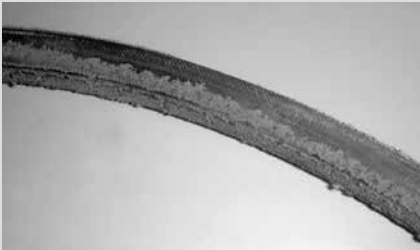

V-BELTS  
SERVICE SOLUTIONS

If further problems arise, contact our engineers from the applications engineering dept. Detailed technical data are necessary for specific assistance.

PROBLEM	POSSIBLE CAUSES	SOLUTION
<p><b>Belt swelling or softening</b></p> 	Contamination by oil, grease, chemicals	Protect drive from contamination. Use raw edge Super X-POWER M=S (SUPER TX) or special execution "05". Clean pulley grooves with petrol or alcohol before using new belts!
<p><b>Belts turn over</b></p> 	<p>Wrong belt/groove section</p> <p>Sheaves do not align</p> <p>Pulley grooves severely worn</p> <p>Tension too low</p> <p>Excessive vibrations</p> <p>Foreign matter in pulley grooves</p>	<p>Realign belt and groove section correctly</p> <p>Realign sheaves</p> <p>Replace sheaves</p> <p>Re-tension drive</p> <p>Use inside idler pulley on drive slack side or OPTIBELT KB kraftbands</p> <p>Remove foreign matter and protect drive</p>
<p><b>Severe belt vibration</b></p>	<p>Drive overloaded (under-dimensioned)</p> <p>Centre distance far larger than recommendations</p> <p>High shock loads</p> <p>Belt tension too low</p> <p>Unbalanced V-grooved sheaves</p>	<p>Check drive conditions and redesign</p> <p>Reduce shaft center distance; use inside idler pulley on the drive slack side.</p> <p>Use OPTIBELT kraftbands.</p> <p>Use OPTIBELT kraftbands.</p> <p>Use inside idler pulley.</p> <p>Use OPTIBELT special execution.</p> <p>Correct tension</p> <p>Balance sheaves</p>
<p><b>Belts cannot be re-tensioned</b></p> 	<p>Allowance of center distance too low</p> <p>Excessive belt stretching, due to under-dimensioned (and overloaded) drive</p> <p>Wrong belt length</p>	<p>Modify drive to allow more take-up according to OPTIBELT recommendations</p> <p>Recalculate drive design and modify</p> <p>Use shorter belt length</p>
<p><b>Excessive running noise</b></p>	<p>Poor drive alignment</p> <p>Belt tension too low</p> <p>Drive overloaded</p>	<p>Realign sheaves</p> <p>Check tension and re tension</p> <p>Check drive conditions and redesign if necessary</p>
<p><b>Uneven belt stretching</b></p> 	<p>Worn or badly machined pulley grooves</p> <p>Used belts mixed with new belts on the same drive</p> <p>Belts from different manufacturers used on the same drive</p>	<p>Replace sheaves</p> <p>Fit completely new set of belts</p> <p>Use belts in sets from one manufacturer only – S=C PLUS, Super X-POWER M=S (SUPER TX), RED POWER</p>

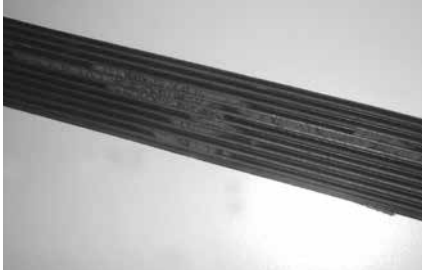

If further problems arise, contact our engineers from the applications engineering dept. Detailed technical data are necessary for specific assistance.

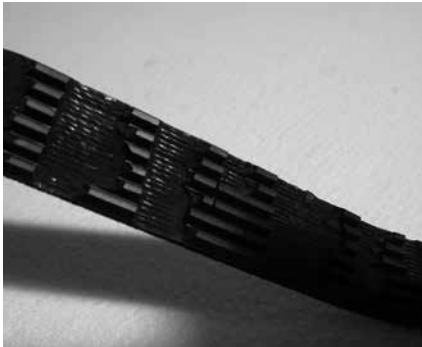

PROBLEM	POSSIBLE CAUSES	SOLUTION
<p><b>Unusual wear and tear of ribs</b></p> 	<p>Tension too low</p> <p>Ingress of foreign matter during operation</p> <p>Sheaves do not align</p> <p>Sheaves defective</p> <p>Wrong rib/pulley section</p>	<p>Correct tension</p> <p>Fit a guard</p> <p>Align sheaves</p> <p>Re-machine or replace sheaves</p> <p>Align rib and pulley section</p>
<p><b>Break of ribbed belts after short running time (belts torn)</b></p> 	<p>Ribbed belt slips or catches on protruding parts</p> <p>Drive blocked</p> <p>Drive overloaded</p> <p>Effects of oil, grease, chemicals</p>	<p>Remove protruding parts; realign drive</p> <p>Remove cause</p> <p>Check drive conditions and redesign</p> <p>Protect drive from environmental influences.</p>
<p><b>Cuts and splits in the ribs (brittleness)</b></p> 	<p>Effects of an outside idler pulley the arrangement and diameter of which does not comply with our recommendations</p> <p>Pulley diameter too small</p> <p>Ambient temperature too high</p> <p>Ambient temperature too low</p> <p>Abnormal belt slip</p> <p>Chemical influences</p>	<p>Comply with OPTIBELT recommendations e.g. increase diameter; use an inside idler pulley on the drive slack side</p> <p>Ensure minimum pulley diameter</p> <p>Remove source of heat, protect belts from direct heat. Improve air ventilation.</p> <p>Warm up ribbed belt before use</p> <p>Re-tension drive according to installation instructions. Check drive conditions and redesign if necessary.</p> <p>Protect drive from contamination</p>

If further problems arise, contact our engineers from the applications engineering dept. Detailed technical data are necessary for specific assistance.

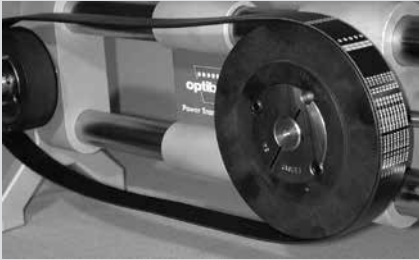





PROBLEM	POSSIBLE CAUSES	SOLUTION
<p><b>Severe vibrations</b></p>	<p>Drive under-dimensioned</p> <p>Shaft center distance far bigger than recommendations</p> <p>High shock loads</p> <p>Tension too low</p> <p>V-grooved sheaves not balanced</p>	<p>Check drive conditions and modify if necessary</p> <p>Reduce shaft center distance. Install idler pulley on drive slack side.</p> <p>Use idler pulley</p> <p>Correct tension</p> <p>Balance sheaves</p>
<p><b>Cannot be re-tensioned</b></p> 	<p>Adjustment allowance of shaft center distance too small</p> <p>Excessive stretching caused by under-dimensioned drive</p> <p>Incorrect ribbed belt length</p>	<p>Correct range of adjustment according to OPTIBELT recommendations</p> <p>Recalculate drive design and modify</p> <p>Install shorter ribbed belt length</p>
<p><b>Excessive running noise</b></p>	<p>Sheaves do not align</p> <p>Tension too low or too high</p> <p>Drive overloaded</p>	<p>Align sheaves</p> <p>Check tension</p> <p>Check drive conditions and redesign</p>
<p><b>Swelling and softening</b></p> 	<p>Effects of oil, fat, chemicals</p>	<p>Protect drive from foreign matter</p> <p>Clean sheaves with petrol or alcohol before using new ribbed belts</p>

**RIBBED BELTS**  
SERVICE SOLUTIONS



If further problems arise, contact our engineers from the applications engineering dept. Detailed technical data are necessary for specific assistance.



PROBLEM	POSSIBLE CAUSES	SOLUTION
<p><b>Belt teeth shearing off (belt break)</b></p> 	<p>Belt kinked before or during installation</p> <p>Overloading</p> <p>Number of engaging teeth too small</p> <p>Foreign matter in the drive</p> <p>Tension too high</p>	<p>Do not kink belts</p> <p>Install wider belts or larger pulleys</p> <p>Increase diameter of small pulley or choose wider belts</p> <p>Remove foreign matter and protect drive</p> <p>Correct tension</p>
<p><b>Severe wear on the tooth edge in use</b></p> 	<p>Incorrect belt tension</p> <p>Overloading, drive under-dimensioned</p> <p>Tooth pitch selection error</p> <p>Defective timing belt pulleys</p>	<p>Correct tension</p> <p>Install wider belts with higher power transmission capability / increase size of timing belt or pulley</p> <p>Check section and replace if necessary</p> <p>Replace timing belt pulleys</p>
<p><b>Unusual wear of sides of belt</b></p> 	<p>Incorrect shaft parallelism</p> <p>Defective flanged pulleys</p> <p>Alteration of shaft center distance</p>	<p>Realign shafts</p> <p>Replace flanged pulleys</p> <p>Reinforce bearings and/or casing</p>
<p><b>Excessive lateral run-off</b></p> 	<p>Incorrect shaft parallelism</p> <p>Timing belt pulleys not aligned</p> <p>Shock load pressure when belt tension is too high</p>	<p>Realign shafts</p> <p>Realign pulleys</p> <p>Reduce belt tension</p>



If further problems arise, contact our engineers from the applications engineering dept. Detailed technical data are necessary for specific assistance.

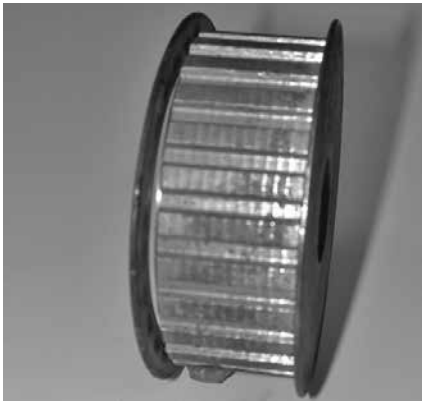

PROBLEM	POSSIBLE CAUSES	SOLUTION
<p><b>Excessive wear at the bottom of the notches</b></p> 	<p>Belt tension too high</p> <p>Drive under-dimensioned</p> <p>Defective timing belt pulleys</p>	<p>Reduce tension</p> <p>Increase size of timing belts and/or pulleys</p> <p>Replace timing belt pulleys</p>
<p><b>Tears in longitudinal direction</b></p> 	<p>Defective flanged pulleys</p> <p>Belt runs up to the flanged pulley</p> <p>Effects of foreign matter during operation</p> <p>Cutting error during cutting of sleeve</p>	<p>Replace flanged pulleys</p> <p>Realign pulleys/shafts; correct tension</p> <p>Remove foreign matter; fit protective guard</p> <p>Check cutting adjustment and sleeve/belt guide setting</p>
<p><b>Flanged pulleys coming off</b></p> 	<p>Timing belt pulleys not aligned</p> <p>Very strong lateral pressure of timing belt</p> <p>Incorrect installation of flanged pulleys</p>	<p>Realign timing belt pulleys</p> <p>Realign shafts</p> <p>Install flanged pulleys correctly</p>
<p><b>Excessive running noise</b></p>	<p>Incorrect shaft alignment</p> <p>Belt tension too high</p> <p>Pulley diameters too small</p> <p>Overloading of timing belt</p> <p>Belt width too large at high speed</p>	<p>Realign shafts</p> <p>Reduce tension</p> <p>Increase diameter of pulleys</p> <p>Increase width of belt or tooth engagement</p> <p>Reduce width of belt by selecting larger belt sections</p>

If further problems arise, contact our engineers from the applications engineering dept. Detailed technical data are necessary for specific assistance.



PROBLEM	POSSIBLE CAUSES	SOLUTION
<p><b>Abnormal wear of timing belt pulleys</b></p>	<p>Unsuitable working material Incorrect engagement of teeth Insufficient hardness of surface</p>	<p>Use harder working materials Replace timing belt pulleys Use harder material or carry out surface hardening</p>
<p><b>Brittleness of top surface</b></p> 	<p>Ambient temperature higher than +85 °C Incompatible radiation</p>	<p>Choose extra heat resistant belt Protect or install suitable belt</p>
<p><b>Tears in the top surface</b></p> 	<p>Ambient temperature below -30 °C</p>	<p>Install cold resistant belt</p>
<p><b>Softening of the top surface</b></p>	<p>Effects of incompatible substances and/or chemicals</p>	<p>Protect or install suitable belt</p>

If further problems arise, contact our engineers from the applications engineering dept. Detailed technical data are necessary for specific assistance.

**TIMING BELTS**  
SERVICE SOLUTIONS



# SERVICE SOLUTIONS MAINTENANCE

# DRIVES & SHEAVES

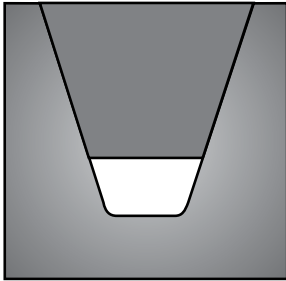

Correct belt arrangement in the V-grooved pulley

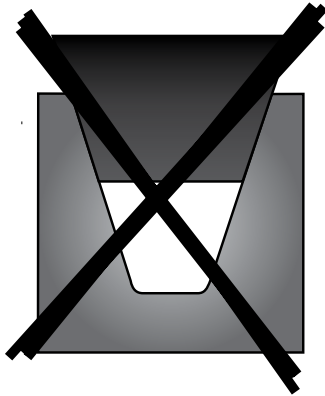

Belt too big/  
pulley groove too small

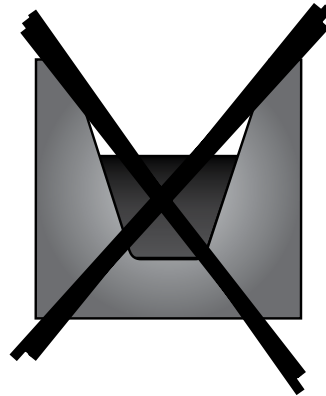

Belt section too small/  
pulley section too big

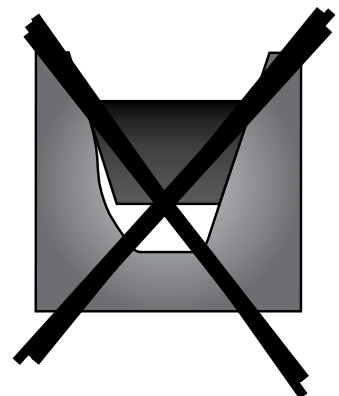

Worn V-grooved pulley

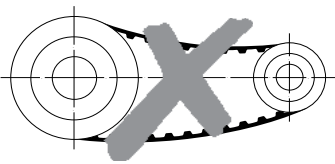

Tension too low

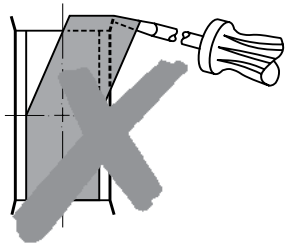

Installation by force

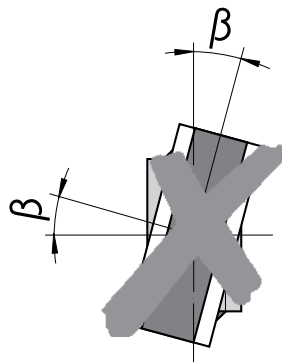

Vertical angle deviation  
of the shafts

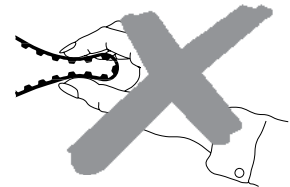

Kinked belt



Aligned sheaves on axially parallel shafts



Axial misalignment of sheaves



Horizontal angle deviation  
of the shafts

OPTIBELT is not responsible for products used for purposes or applications in which they were not designed or manufactured for. This information is contained in OPTIBELT's General Terms of Business.



# CONVERSION TABLE

BELT SIZES



## SK WEDGE BELTS TO BS 3790/DIN 7753

SECTION	CROSS SECTION $b \times h =$	SECTION BASE WIDTH $b_o =$	DATUM WIDTH $b_d$	BELT LENGTH				RECOMMENDED MINI-MUM PULLEY DIAMETER (MM)	BELT WEIGHT (= KG/M)	
				DATUM LENGTH	OUTSIDE LENGTH $L_o$	DATUM LENGTH $L_d$	INSIDE LENGTH $L_i$			
SPZ	9.7 x 8	4.2	8.5	DATUM LENGTH $L_d$	$L_o = L_d + 13$ $L_o = L_i + 51$	—	$L_i = L_d - 38$ $L_i = L_o - 51$	DATUM DIA. $D_d$	63	.074
SPA	12.7 x 10	5.8	11		$L_o = L_d + 18$ $L_o = L_i + 63$	—	$L_i = L_d - 45$ $L_i = L_o - 63$		90	.123
SPB	16.3 x 13	7.3	7.3		$L_o = L_d + 22$ $L_o = L_i + 82$	—	$L_i = L_d - 60$ $L_i = L_o - 82$		140	.195
SPC	22 x 18	9.6	9.6		$L_o = L_d + 30$ $L_o = L_i + 113$	—	$L_i = L_d - 83$ $L_i = L_o - 113$		224	.377

## SK WEDGE BELTS TO US STANDARD RMA/MPTA

3V/9N	9 x 8	4.2	—	OUTSIDE LENGTH $L_o$	—	$L_d = L_o - 4^*$	$L_i = L_o - 42$	OUTSIDE DIA. $D_o$	63	.074
5V/15N	15 x 13	7.3	—		—	$L_d = L_o - 11^*$	$L_i = L_o - 71$		140	.195
8V/25N	25 x 23	9.6	—		—	—	$L_i = L_o - 120$		335	.575

\* The conversion factor  $L_d$  to  $L_o$  is used when a section according to DIN 7753 Part 1 is to be replaced by the corresponding section according to RMA/MPTA.

## SUPER X-POWER M=S WEDGE BELTS (RAW EDGE, MOLDED COGGED) TO BS 3790/DIN 775

XPZ	9.7 x 8	4.2	8.5	DATUM LENGTH $L_d$	$L_o = L_d + 13$ $L_o = L_i + 51$	—	$L_i = L_d - 38$ $L_i = L_o - 51$	DATUM DIA. $D_d$	56	.065
XPA	12.7 x 10	5.8	11		$L_o = L_d + 18$ $L_o = L_i + 63$	—	$L_i = L_d - 45$ $L_i = L_o - 63$		71	.111
XPB	16.3 x 13	7.3	14		$L_o = L_d + 22$ $L_o = L_i + 82$	—	$L_i = L_d - 60$ $L_i = L_o - 82$		112	.183
XPC	22 x 18	9.6	19		$L_o = L_d + 30$ $L_o = L_i + 113$	—	$L_i = L_d - 83$ $L_i = L_o - 113$		180	.340

## SUPER X-POWER M=S WEDGE BELTS (RAW EDGE, MOLDED COGGED) TO BS 3790/DIN 7753

3VX/9NX	9 x 8	4.2	—	OUTSIDE LENGTH $L_o$	—	$L_d = L_o - 4^*$	$L_i = L_d - 42$	OUTSIDE DIA. $D_o$	56	.065
5VX/15NX	15 x 13	7.3	—		—	$L_d = L_o - 11^*$	$L_i = L_d - 71$		112	.183

\* The conversion factor  $L_d$  to  $L_o$  is used when a section to BS 3790 or DIN 7753 Part 1 is to be replaced by the corresponding section to RMA/MPTA.

## SUPER TX M=S V-BELTS - TO RAW EDGE, MOLDED COGGED

ZX/X10	10 x 6	5.9	8.5	DATUM LENGTH $L_d$	$L_o = L_i + 38$ $L_o = L_d + 16$	—	$L_i = L_d - 22$ $L_i = L_o - 38$	DATUM DIA. $D_d$	40	.062
AX/X13	13 x 8	7.5	11		$L_o = L_i + 50$ $L_o = L_d + 20$	—	$L_i = L_d - 30$ $L_i = L_o - 50$		63	.099
BX/X17	17 x 11	9.4	14		$L_o = L_i + 69$ $L_o = L_d + 29$	—	$L_i = L_d - 40$ $L_i = L_o - 69$		90	.165
CX/X22	22 x 14	12.3	19		$L_o = L_i + 88$ $L_o = L_d + 30$	—	$L_i = L_d - 58$ $L_i = L_o - 88$		140	.276

CONVERSIONS REFERENCE



# CONVERSION TABLE

## BELT SIZES

### VB CLASSICAL V-BELTS TO BS 3790/DIN 2215

SECTION	CROSS SECTION $b \times h =$	SECTION BASE WIDTH $b_u =$	DATUM WIDTH $b_d$	BELT LENGTH				RECOMMENDED MINIMUM PULLEY DIAMETER (MM)	BELT WEIGHT (= KG/M)	
				NOMINAL LENGTH	OUTSIDE LENGTH $L_o$	DATUM LENGTH $L_a$	INSIDE LENGTH $L_i$			
<b>5</b>	5 x 3	2.8	4.2	DATUM LENGTH $L_d$	$L_o = L_i + 19$ $L_o = L_d + 8$	$L_d = L_i + 11$ $L_d = L_o - 8$	—	DATUM DIA. $D_d$	20	.018
<b>Y/6</b>	6 x 4	3.3	5.3		$L_o = L_i + 25$ $L_o = L_d + 10$	$L_d = L_i + 15$ $L_d = L_o - 10$	—		28	.026
<b>8</b>	8 x 5	4.5	6.7		$L_o = L_i + 31$ $L_o = L_d + 12$	$L_d = L_i + 19$ $L_d = L_o - 12$	—		40	.042
<b>Z/10</b>	10 x 6	5.9	8.5		$L_o = L_i + 38$ $L_o = L_d + 16$	$L_d = L_i + 22$ $L_d = L_o - 16$	—		50	.064
<b>A/13</b>	13 x 8	7.5	11		$L_o = L_i + 50$ $L_o = L_d + 20$	$L_d = L_i + 30$ $L_d = L_o - 20$	—		71	.109
<b>B/17</b>	17 x 11	9.4	14		$L_o = L_i + 69$ $L_o = L_d + 29$	$L_d = L_i + 40$ $L_d = L_o - 29$	—		112	.196
<b>20</b>	20 x 12.5	11.4	17		$L_o = L_i + 79$ $L_o = L_d + 31$	$L_d = L_i + 50$ $L_d = L_o - 31$	—		160	.266
<b>C/22</b>	22 x 14	12.3	19		$L_o = L_i + 88$ $L_o = L_d + 30$	$L_d = L_i + 58$ $L_d = L_o - 30$	—		180	.324
<b>25</b>	25 x 16	14	21		$L_o = L_i + 100$ $L_o = L_d + 39$	$L_d = L_i + 60$ $L_d = L_o - 39$	—		250	.420
<b>D/32</b>	32 x 20	18.2	27		$L_o = L_i + 126$ $L_o = L_d + 51$	$L_d = L_i + 75$ $L_d = L_o - 51$	—		355	.668
<b>E/40</b>	40 x 25	22.8	32	$L_o = L_i + 157$ $L_o = L_d + 77$	$L_d = L_i + 80$ $L_d = L_o - 77$	—	500	.958		

### DK DOUBLE SECTION V-BELTS TO DIN 7722/ISO 5289

SECTION	CROSS SECTION $b \times h =$	SECTION BASE WIDTH $b_u =$	NOMINAL LENGTH	BELT LENGTH	RECOMMENDED MINIMUM PULLEY DIAMETER (MM)	BELT WEIGHT (= kg/m)	
AA/HAA	13 x 10	—	EFFECTIVE LENGTH	Effective length = center length - 4	OUTSIDE DIAMETER $D_a$	80	.150
BB/HBB	17 x 13	—		Effective length = center length - 8		125	.250
CC/HCC	22 x 17	—		Effective length = center length + 3		224	.440
DD/HDD	32 x 25	—		Effective length = center length		355	.935

### DK DOUBLE SECTION V-BELTS TO SPECIAL SECTIONS

22 x 22	22 x 22	—	EFFECTIVE LENGTH	Effective length = center length	OUTSIDE DIAMETER $D_a$	280	.511
25 x 22	25 x 22	—		Effective length = center length		280	.625

# CONVERSION TABLE

## BELT SIZES



### KB KRAFTBAND WEDGE TO ISO 5290/USA STANDARD RMA/MPTA

SECTION	HEIGHT H=	BOTTOM WIDTH B <sub>U</sub> = OF THE SINGLE BELTS	BELT LENGTH				RECOMMENDED MINIMUM PULLEY DIAMETER (mm)	RIB WEIGHT (=kg/m)	
			NOMINAL LENGTH	OUTSIDE LENGTH L <sub>o</sub>	DATUM LENGTH L <sub>d</sub>	INSIDE LENGTH L <sub>i</sub>			
3V/9J	9.9	4.2	OUTSIDE LENGTH L <sub>o</sub>	—	—	L <sub>i</sub> = L <sub>o</sub> - 42	OUTSIDE DIAMETER D <sub>a</sub>	67	.122
5V/15J	15.1	7.3		—	—	L <sub>i</sub> = L <sub>o</sub> - 71		180	.252
8V/25J	25.5	9.6		—	—	L <sub>i</sub> = L <sub>o</sub> - 120		315	.693

### KB KRAFTBAND WEDGE BELTS

SECTION	HEIGHT H=	BOTTOM WIDTH B <sub>U</sub> = OF THE SINGLE BELTS	DATUM LENGTH L <sub>d</sub>	L <sub>o</sub> = L <sub>d</sub> + 13	—	—	DATUM DIAMETER D <sub>d</sub>	80	.120
SPZ	10.5	5.4		L <sub>o</sub> = L <sub>d</sub> + 18	—	—		112	.166
SPA	12.5	7		L <sub>o</sub> = L <sub>d</sub> + 22	—	—		160	.261
SPB	15.6	8.8		L <sub>o</sub> = L <sub>d</sub> + 24	—	—		250	.555

## DATUM TO OUTSIDE LENGTH CONVERSIONS

**SPZ CONVERSION:** OUTSIDE LENGTH = DATUM LENGTH +13mm

**SPB CONVERSION:** OUTSIDE LENGTH = DATUM LENGTH +22mm

**SPA CONVERSION:** OUTSIDE LENGTH = DATUM LENGTH +18mm

**SPC CONVERSION:** OUTSIDE LENGTH = DATUM LENGTH +30mm

### KB KRAFTBANDS V-BELTS

SECTION	HEIGHT H=	BOTTOM WIDTH B <sub>U</sub> = OF THE SINGLE BELTS	DATUM LENGTH L <sub>d</sub>	L <sub>o</sub> = L <sub>i</sub> + 36	L <sub>d</sub> = L <sub>i</sub> + 30	—	DATUM DIAMETER D <sub>d</sub>	80	.163
A	9.9	7.5		L <sub>o</sub> = L <sub>i</sub> + 62	L <sub>d</sub> = L <sub>i</sub> + 40	—		125	.266
B	13	9.4		L <sub>o</sub> = L <sub>i</sub> + 75	L <sub>d</sub> = L <sub>i</sub> + 58	—		200	.447
C	16.2	12.3		L <sub>o</sub> = L <sub>i</sub> + 111	L <sub>d</sub> = L <sub>i</sub> + 75	—		355	.798

### KB KRAFTBANDS TO USA STANDARD ASAE S 211. ...

SECTION	HEIGHT H=	BOTTOM WIDTH B <sub>U</sub> = OF THE SINGLE BELTS	BELT LENGTH				RECOMMENDED MINIMUM PULLEY DIAMETER (mm)	RIB WEIGHT (=kg/m)	
			OUTSIDE LENGTH	OUTSIDE LENGTH L <sub>o</sub>	DATUM LENGTH L <sub>d</sub>	INSIDE LENGTH L <sub>i</sub>			
HA	9.9	7.5	OUTSIDE LENGTH L <sub>o</sub>	—	—	L <sub>i</sub> = L <sub>o</sub> - 36	OUTSIDE DIAMETER D <sub>a</sub>	80	.163
HB	13	9.4		—	—	L <sub>i</sub> = L <sub>o</sub> - 62		125	.266
HC	16.2	12.3		—	—	L <sub>i</sub> = L <sub>o</sub> - 75		200	.447
HD	22.4	18.2		—	—	L <sub>i</sub> = L <sub>o</sub> - 111		355	.798

The width of the kraftband (banded belt) is dependent upon the number of ribs.

### FB AUTOMOTIVE FAN BELTS

SECTION	CROSS-SECTION b x h =	SECTION BOTTOM WIDTH B <sub>U</sub> =	DATUM WIDTH B <sub>d</sub>	BELT LENGTH				RECOMMENDED MINIMUM PULLEY DIAMETER (mm)	RIB WEIGHT (=kg/m)
				NOMINAL LENGTH	OUTSIDE LENGTH L <sub>o</sub>	DATUM LENGTH L <sub>d</sub>	INSIDE LENGTH L <sub>i</sub>		
9.5	10 x 8	4.9	8.5	OUTSIDE LENGTH L <sub>o</sub>	—	L <sub>d</sub> = L <sub>o</sub> - 13	L <sub>i</sub> = L <sub>o</sub> - 51	SEE OEM SPECS.	.070
12.5	13 x 10	5.8	11		—	L <sub>d</sub> = L <sub>o</sub> - 18	L <sub>i</sub> = L <sub>o</sub> - 63		.118

### MARATHON 1/MARATHON 2 AUTOMOTIVE V-BELTS TO RAW EDGE, MOLDED COGGED

AVX 10	10 x 8	4.9	8.5	OUTSIDE LENGTH L <sub>o</sub>	—	L <sub>d</sub> = L <sub>o</sub> - 13	L <sub>i</sub> = L <sub>o</sub> - 51	SEE OEM SPECS.	.076
AVX 13	13 x 10	5.8	11		—	L <sub>d</sub> = L <sub>o</sub> - 18	L <sub>i</sub> = L <sub>o</sub> - 63		.118



# V-BELT SECTIONS

## REFERENCE DIMENSIONS

### V-BELTS/COGGED, CLASSIC

INCHES (IN)



### V-BELTS/COGGED, RMA/MPTA

INCHES (IN)

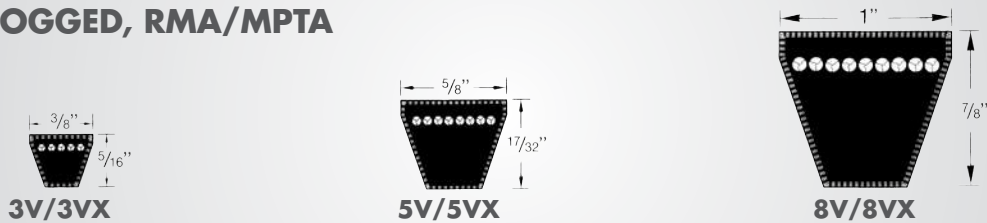

### V-BELTS/COGGED, METRIC

MILLIMETERS (MM)



### V-BELTS, CLASSICAL METRIC

MILLIMETERS (MM)

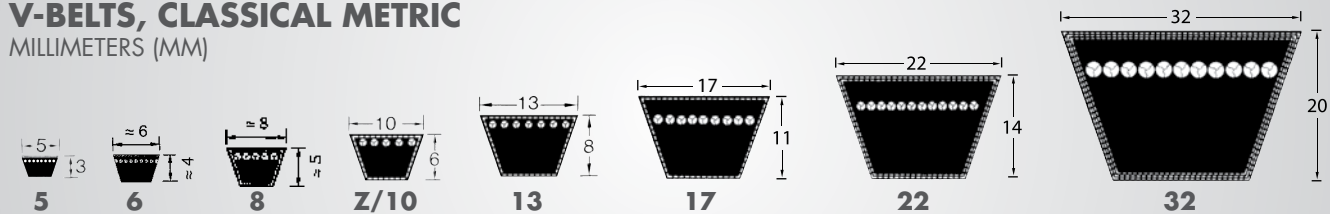

### BANDED/COGGED, CLASSIC

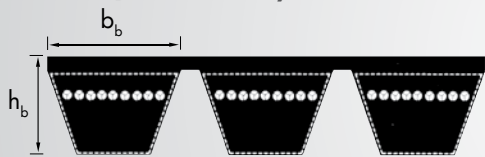

SECTION	B/BX		C/CX		D	
	INCH	MM	INCH	MM	INCH	MM
$b_b \approx$	21/32	17.0	7/8	22.0	1 1/4	32.0
$h_b \approx$	1/2	13.0	41/64	16.2	7/8	22.4

### BANDED/COGGED, RMA/MPTA

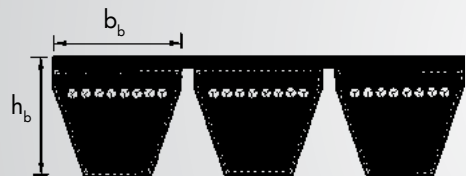

SECTION	3V/3VX		5V/5VX		8V	
	INCH	MM	INCH	MM	INCH	MM
$b_b \approx$	3/8	9.0	5/8	15.0	1	25.0
$h_b \approx$	25/64	9.9	5/8	15.1	1 1/64	25.5

### BANDED/COGGED, METRIC



SECTION	SPZ	SPA	SPB	SPC
	MM	MM	MM	MM
$b_b \approx$	9.7	12.7	16.5	22.0
$h_b \approx$	10.5	12.5	15.6	22.6

SECTIONS  
REFERENCE

# RIBBED & TIMING BELT SECTIONS

## REFERENCE DIMENSIONS



### RIBBED BELTS

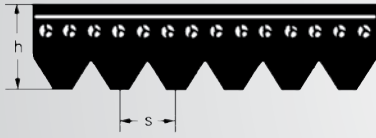

SECTION	H/PH		J/PJ		K/PK		L/PL		M/PM	
	INCH	MM	INCH	MM	INCH	MM	INCH	MM	INCH	MM
s	0.063	1.60	0.092	2.34	0.140	3.56	0.185	4.70	0.370	9.40
h	0.10	2.50	0.14	3.50	0.18	4.60	0.28	7.00	0.51	13.00

### TIMING BELTS MXL, XL, L, H, XH, XXH

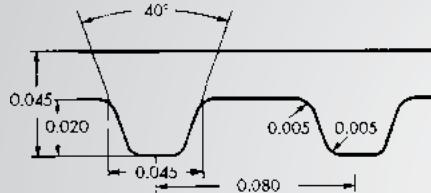

**MXL** .080 IN. PITCH

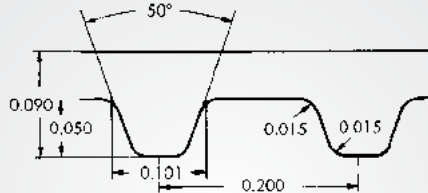

**XL** .200 IN. PITCH

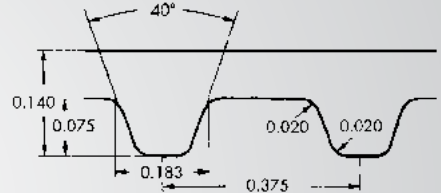

**L** .375 IN. PITCH

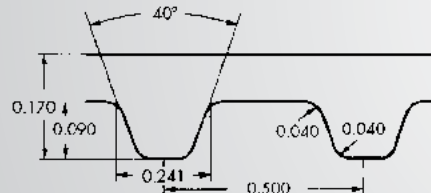

**H** .500 IN. PITCH

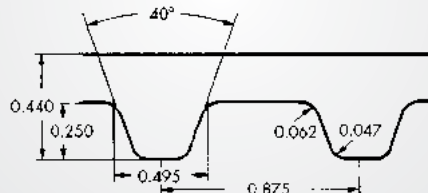

**XH** .875 IN. PITCH

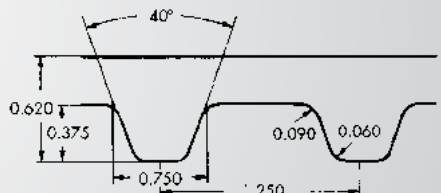

**XXH** 1.250 IN. PITCH

### TIMING BELTS 2M, 3M, 5M, 8M, 14M

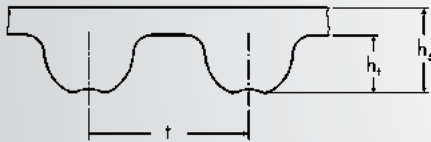

SECTION	(MM)		
	t	h <sub>t</sub>	h <sub>s</sub>
2M	2	.07	1.5
3M	3	1.1	2.3
5M	5	1.9	3.4

SECTION	(MM)		
	t	h <sub>t</sub>	h <sub>s</sub>
8M	8	3.2	5.4
14M	14	5.6	9.5

### TIMING BELTS T2.5, T5, T10, T20

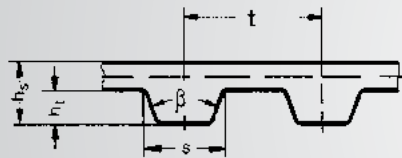

SAMPLE PART NO.  
10 T10 / 700  
— LENGTH (MM)  
— PITCH 10 MM  
— WIDTH (MM)

SECTION	(MM)				
	t	h <sub>t</sub>	h <sub>s</sub>	s	β
T2.5	2.5	.70	1.30	1.50	40°
T5	5.0	1.20	2.20	2.65	40°
T10	10.0	2.50	4.50	3.50	40°
T20	20.0	5.0	8.0	6.5	40°

### TIMING BELTS AT5, AT10, AT20

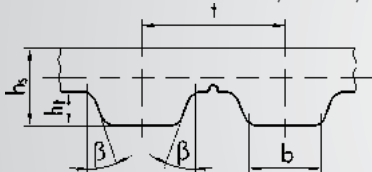

SAMPLE PART NO.  
10 AT5 / 300  
— LENGTH (MM)  
— PITCH 5 MM  
— WIDTH (MM)

SECTION	(MM)				
	t	h <sub>t</sub>	h <sub>s</sub>	b	β
AT5	5.0	1.20	2.70	2.5	40°
AT10	10.0	2.50	4.50	5.0	40°
AT20	20.0	5.0	8.0	10	40°



# PRODUCT SELECTION GUIDE

This table is intended to simplify the selection of OPTIBELT products according to their specifications.	Temperature resistance from ... to ... [°F]		Oil resistance		Electrically conductive	S=C plus Set Constant <sup>1)</sup> M=S Matched Sets <sup>2)</sup>	Mining industry approval	Smooth running	Permanent stretch	
	Standard design	Special design XHR	Standard design	Special design					Standard design	Special design
SK / SK KB standard & metric v-belts/ banded	-40 +158	-22 +194	good	excellent	yes	yes <sup>1)</sup>	yes	medium/ good	low	very low
RED POWER 3 / KB RED POWER 3 high performance v-belts/ banded	-22 +212		good		yes	yes <sup>1)</sup>		good	none	
BLUE POWER / KB BLUE POWER industrial power v-belts/ banded	-22 +212		good		yes			good	none	
SUPER X-POWER / KBX / SUPER TX raw edge, molded cogged v-belts	-22 +194		good		yes	yes <sup>2)</sup>		good	very low	
SUPER E-POWER	-58 +248		limited		yes			good	very low	
MARATHON 1, MARATHON 2 automotive v-belts	-22 +194		good		yes	yes <sup>2)</sup>		good	very low	
VB classic v-belts	-40 +158	-22 +194	good	excellent	yes	yes <sup>1)</sup>	yes	medium/ good	low	very low
DK double-sided v-belts	-31 +185		good		yes			medium	low	
SUPER VX / VARIO POWER variable speed belts	-22 +194		good		yes			excellent	very low	
RB ribbed belts	-22 +194	-22 +248	good		• PJ PK, PL special constructions			excellent	low	

PROD. GUIDE REFERENCE

MARATHON 1 & 2 immediate stock may be limited. Contact an OPTIBELT representative for information.

• after testing

# PRODUCT SELECTION GUIDE



Recommended max. belt speed feet/sec. meters/sec.	Efficiency	Behavior under shock loading	Vibration tendency	Synchronous	Recommended max. speed ratio	Suitable for outside idlers		Maintenance	Suggested application usages. (Not all applications listed)
						Standard construction	Special construction		
≤ 138 ≤ 42	up to 97%	good	low	no	up to 1 : 10	limited	good	low	Compressors, mixers, rotary print machines, extruders, screw compressors, weaving machines, axial fans, rotary pumps
≤ 180* ≤ 55*	up to 97%	good	low	no	up to 1 : 10	good		maintenance-free (no tension maintenance)	Fans, pumps, mixers, mills, special machines, lathes and drilling machines, grinding machines, agriculture equipment
≤ 180* ≤ 55*	up to 97%	good	low	no		good		low	High power industrial equipment: pumps, mills, crushers, drilling, grinders, agriculture equipment
depends on profile ≤ 180* ≤ 55*	up to 97%	good	low	no	up to 1 : 12	limited	good	SUPER X-POWER: low maintenance	Fans, pumps, mixers, mills, special machines, lathes and drilling machines, grinding machines
≤ 180* ≤ 55*	up to 97%	good	low	no	up to 1 : 12	limited		low	Fans, pumps, mixers, mills, special machines, lathes and drilling machines, grinding machines
≤ 138 ≤ 42	up to 97%	good	low	no	up to 1 : 12	limited	good	low	Motor vehicles, generators, water pumps, fans
≤ 99 ≤ 30	up to 97%	good	low	no	up to 1 : 12	limited	good	low	Pumps, presses, crushers, disk saws, box column drilling machines, plane machines, concrete mixers, compactors, lawn mowers, aerators, baling presses, shredders
≤ 99 ≤ 30	up to 95%	good	low	no	up to 1 : 5	excellent	good	low	Special drives with changing rotary directions, weaving looms, sweepers, harvesters
depends on profile ≤ 138 ≤ 42	up to 95%	good	low	no	up to 1 : 12 for 2 variable speed pulleys	limited		low	Special drives, compact units, snow mobile drives, multi-color offset printing machines, variable speed pulley sets, threshing drum drives, winding machines, lathes
depends on profile ≤ 197 ≤ 60	up to 96%	good	very low	no	up to 1 : 35	good		low	Offset machines, washing machines, milling machines, electric floor polishers, auxiliaries, main spindle drives

\* For optimum v-belt performance above 138 ft/s or 42 m/s. please contact our Application Engineering Department.

**PROD. GUIDE**  
 REFERENCE



# PRODUCT SELECTION GUIDE

This table is intended to simplify the selection of OPTIBELT products according to their specifications.	Temperature resistance from ... to ... [°F]		Oil resistance	Electrically conductive	Smooth running	Permanent stretch
	Standard design	Special design XHR	Standard design			
OMEGA, OMEGA HP + OMEGA HL timing belts	-22 +212	-22 +140	limited	yes*	medium/good	none
ZR timing belts	-22 +212	-22 +284	limited	yes	medium	none
ALPHA polyurethane timing belts	-22 +176		good	no	medium	none
RR round belts	-14 +176		good	no	medium	high
KK V-belting	-10 +176		good	no	medium	high
Optimat OE open-ended V-belts, DIN 2216, punched	-4 +158		limited	no	medium	high
PKR endless timing belts with patterned top surface	-22 +158		limited	yes	medium	low
Optimax HF endless high performance flat belts	-20 +230		limited	no	excellent	low

**PROFILES**  
REFERENCE

OPTIMAX HF is a non-stock item in the USA. Contact an OPTIBELT representative for details.

\* after testing





	Recommended max. belt speed feet/sec. meters/sec.	Efficiency	Behaviour with shock loads	Vibration behaviour	Synchronous running	Recommended max. conversion	Suitable for outside idlers		Maintenance	Suggested application usages. (Not all applications listed)
							Standard design	Special design		
	depends on profile ≤ 263 ≤ 80	up to 98%	sensitive	depends on speed	yes	up to 1 : 10	good	good	maintenance-free	Textile machines, spinning machines, weaving machines, printing machines, paper machines, woodworking machines, machine tools, linear units, roller conveyors, ski systems, packaging machines, gate and door openers, lifting devices, mixers, extruders, compressors
	depends on profile ≤ 263 ≤ 80	up to 98%	sensitive	depends on speed	yes	up to 1 : 10	good	good	maintenance-free	Copying machines, household appliances, swivel arm robots, gripper drives, belt grinders, camshaft drives, brush drives, clocks, X-Ray devices, enveloping machines, cameras, plotters, slot machines, main machines and feeders, feed drives, material feed, printers
	depends on profile ≤ 263 ≤ 80	up to 98%	sensitive	depends on speed	yes	up to 1 : 10	good	good	maintenance-free	Cameras, plotters, printers, slot machines, main machines and feeders, feed drives, material feed, test conveyance, flight models
	≤ 66 ≤ 20	up to 95%	good	low	no	up to 1 : 10	good	good	tensioning maintenance required	Special machinery
	≤ 66 ≤ 20	up to 95%	good	low	no	up to 1 : 10	good	good	tensioning maintenance required	Packaging machines, conveyor units, enamelling lines, accumulating conveyor, for difficult installation conditions
	≤ 66 ≤ 20	up to 90%	good	medium	no	up to 1 : 10	limited		tensioning maintenance required	Where installation conditions are difficult
	depends on profile ≤ 263 ≤ 80	up to 95%	good	low	no	up to 1 : 10	limited	good	low	Conveyor units in the wood industry, in concrete factories, in the agricultural industry, ceramic industry, glass industry, at airports, in seaports and inland ports
	≤ 230 ≤ 70	up to 95%	good	very low	no	up to 1 : 12	excellent		low	Water turbines, emergency power generators, saw gates, hackers, screw compressors, roller drives, transmission drives, conical drives, cross cutters, floor cleaners, multi-drives, crushers, close belts, hammer mills



# CONVERSION TABLE

## WEIGHTS & MEASURES

### STANDARD FRACTION CONVERSION TO DECIMALS & MILLIMETERS

FRACTIONS INCHES	DECIMALS	MM	FRACTIONS INCHES	DECIMALS	MM
17/64	.265625	6.747	33/64	.515625	13.097
9/32	.28125	7.144	17/32	.53125	13.494
19/64	.296875	7.541	35/64	.546875	13.891
5/16	.3125	7.938	9/16	.5625	14.288
21/64	.328125	8.334	37/64	.578125	14.684
11/32	.34375	8.731	19/32	.59375	15.081
23/64	.359375	9.128	39/64	.609375	15.478
3/8	.375	9.525	5/8	.625	15.875
25/64	.390625	9.922	41/64	.640625	16.272
13/32	.40625	10.319	21/32	.65625	16.669
27/64	.421875	10.716	43/64	.671875	17.066
7/16	4.375	11.113	11/16	.6875	17.463
29/64	.453125	11.509	45/64	.703125	17.859
15/32	.46875	11.906	23/32	.71875	18.256
31/64	.484375	12.303	47/64	.734375	18.653
1/2	.5	12.7	3/4	.75	19.05

### WEIGHT

METRIC TO US		US TO METRIC	
METRIC	US	US	METRIC
1 G	981 DYNES	1 DYNE	.0010193 G
1 G	.035274 OZ.	1 OZ.	28.3495 G
1 KG	35.274 OZ.	1 OZ.	.0283495 KG
1 KG	2.20462 LB.	1 LB.	.453592 KG

**KEY:** G = GRAMS KG = KILOGRAMS OZ. = OUNCE LB. = POUND

### LENGTHS

METRIC TO US		US TO METRIC	
METRIC	US	US	METRIC
1 MM	.39370 IN.	1 IN.	25.4 MM
1 M	39.37 IN.	1 IN.	.0254 M
1 M	3.2808 FT.	1 FT.	.3048 M
1 M	1.09381 YARDS	1 YARD	.9144 M

**KEY:** MM = MILLIMETERS M = METERS IN. = INCHES FT. = FEET

### NOTES

---

---

---

---

---

---

---

---

---

---

---

---

---

---

---

---

---

---

---

---

---

---

---

---

All weights listed are approximated.  
Concerning product liability and delivery, consult OPTIBELT's general terms and conditions.



## SUPERIOR ENGINEERED PRODUCTS



### WHO IS OPTIBELT?

OPTIBELT is a multinational belt manufacturer that has been in business for over 140 years. Our Engineering and state-of-the-art manufacturing capabilities allow us to supply the highest quality products in the industry.

#### WAREHOUSE & DISTRIBUTION LOCATIONS

Fast and easy shipping throughout the USA.  
South Carolina - Texas - Illinois - California

#### PRODUCTS

A full range of power transmission belts are available:  
V-Belts - Timing - Ribbed - Banded - Cogged - Specialty

### WHY CUSTOMERS CHOOSE OPTIBELT

#### MORE DURABILITY

Customers that have a difficult drive set-up or application where standard belts are over-stressed, products such as optibelt's RED POWER often solves these issues.

#### GREATER EFFICIENCY

Customers seeking to optimize their facilities will discover OPTIBELT's superior wear resistance and high power transfer capacity will reduce their yearly costs.

#### REDUCED MAINTENANCE

When customers are looking to reduce downtime or overall maintenance costs, OPTIBELT offers the only maintenance-free belt in the industry: RED POWER 3.

## OPTIBELT'S INDUSTRY LEADING ADVANTAGES

#### S=C PLUS (Set-Constant)

Superior than industry standards for a matched-set. Any two S=C Plus V-belts are always a matched set regardless of when they were manufactured.

#### CUT TO SIZE WIDTHS

Customers get greater flexibility when they are ordering banded, timing or ribbed belts. Every OPTIBELT facility cuts belts to size so there is no wait for custom orders from the factory.

#### METRIC SIZES

OPTIBELT'S international presence make us the leading supplier of metric belts in the world.

#### HVAC POWER

Specific HVAC engineered V-belts can withstand extreme temperatures, extend maintenance intervals, are very flexible, and have S=C Plus length tolerances.

#### BLUE POWER: Aramid Cord

BLUE POWER V-belts are the strongest available for heavy industrial applications and their high-grip cover is dual wrapped for increased durability.

#### RED POWER: Maintenance-Free

RED POWER 3 is the only maintenance-free belt. The cord is made with a custom polymer that keeps the belt tensioned throughout its life.

RED POWER belts also offer up to a 50% increase in power transfer capacity, are dual wrapped cover for dramatically longer belt life, and have S=C Plus length tolerances.

## **USA**

### **ILLINOIS (HEADQUARTERS)**

565 E. Fullerton Ave.  
Carol Stream, IL 60188  
**T** 800-292-6081  
**F** 800-542-9510

### **SOUTH CAROLINA**

105 Ben Hamby Rd., Unit F  
Greenville, South Carolina 29615  
**T** 864-328-0285  
**F** 864-288-5999

### **TEXAS**

1225 E. Crosby Rd., B14  
Carrollton, TX 75006  
**T** 972-591-2258  
**F** 972-242-1051

### **CALIFORNIA**

10911 Painter Ave.  
Santa Fe Springs, CA 90670  
**T** 562-781-7102  
**F** 562-941-5049

## **CANADA**

### **TORONTO**

351 Steelcase Road West,  
Unit 8 & 9  
L3R 4H9 Markham, Ontario  
**T** 905-477-8114  
**F** 905-477-0857  
**E** info@optibelt.ca

### **MONTREAL**

4915, Place Olivia, Suite 100  
H4R 2V6 Saint-Laurent, QC  
**T** 514-856-0550  
**F** 514-856-1790

## **MEXICO**

Avenida 5 de Febrero 1702-C,  
Bodega 5, Colonia las Americas  
76121 Santiago De Queretaro, QRO  
Mexico  
**T** +52 442-210-3741  
**E** info@optibelt.mx

## **LATIN AMERICA**

**T** 630-628-8400  
**E** latin-info@optibelt.com



**OPTIBELT-USA.COM**

**TOLL FREE: 800-292-6081**

**E-MAIL: info@optibelt-usa.com**

**FAX: 800-542-9510**